

# SULZER

## Cutting-edge pumping solutions for the power generation

---

Sulzer's high-performance pumps ensure efficient operation across fossil-fired, nuclear, and renewable power generation, providing the reliability you need.  
[sulzer.com/power-generation](https://www.sulzer.com/power-generation)



# The Sulzer advantage

---

The ever growing demand of energy in the world constitutes a challenge for power suppliers. In their search for reliable and always more competitive solutions, they have successfully turned to Sulzer. More than pumps, Sulzer provides complete and sustainable systems and services for a greener future.

## Energy efficiency

- The increase of energy efficiency policies pressures utilities to constantly strive to improve their processes
- Sulzer benefits from extensive experience in improving energy and works towards energy savings to make utilities the most competitive in their field

## Environmental responsibility

- Sulzer provides pumping solutions dedicated to lowering energy costs and increasing reliability of your system while preserving the environment
- Limiting the environmental footprint is a value which Sulzer implements within and outside its walls

## Reliability

- Because downtimes are expensive, Sulzer offers proven solutions
- Through its wide testing capabilities, Sulzer is able to test pumping solutions prior to shipment for even more reliability



## Our footprint spans across the globe

All Sulzer manufacturing plants have advanced testing facilities, capable of demonstrating pump performance and proving the ancillary equipment to ensure smooth commissioning and start-up.

## Quality and sustainability

We are committed to providing our customers with the best products and services at the highest quality standards in the industry. At all our locations worldwide, we implement certified management systems, according to ISO 9001, ISO 14001 and OHSAS 18001 as an effective way to sustain the continuous improvement of our processes and products. Some of our locations have specific certificates such as ATEX IECEx03.

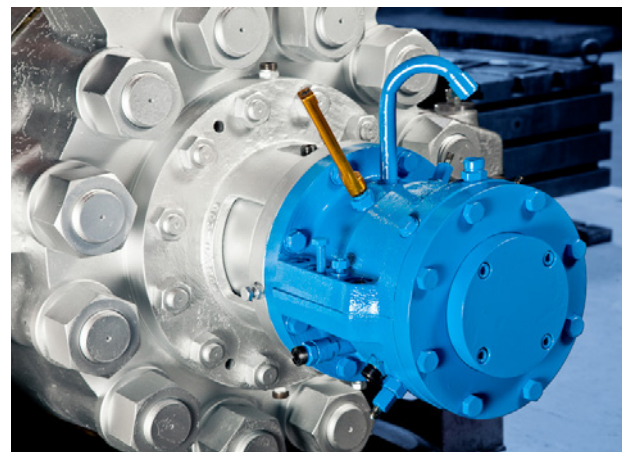

# You set out the challenge, we present the solutions

## 1 Coal- and oil-fired power plants

Pumps for boiler feedwater, condensate extraction, cooling water and associated auxiliary applications

## 2 Gas-fired power plants

Pumps for feedwater, condensate extraction, cooling water, fuel injection, NOx abatement and associated auxiliary applications

## 3 Nuclear power plants

Pumps for feedwater, condensate extraction, cooling water, nuclear safety services and associated auxiliary applications

## 4 Biomass-fired power plants

Pumps for boiler feedwater, condensate extraction, cooling water and associated auxiliary applications

## 5 Solar thermal power plants

Pumps for feedwater, condensate extraction, cooling water, Heat Transfer Fluid (HTF) oil circulation, molten salt and associated auxiliary applications

## 6 Geothermal power plants

Pumps for hot water production, hydrocarbon feed, condensate extraction, cooling water, brine reinjection and associated auxiliary applications

## 7 Pumped-storage hydro power plants

Storage pumps and power recovery turbines



# Your ideal service partner

Our global aftermarket presence, expertise and commitment always deliver reliability, responsiveness, rapid turn-around and innovative solutions.



## Diagnostic and consulting services

Consulting  
Monitoring  
Inspection



Take informed  
decisions and  
maintain control



## Maintenance and support services

On-site services  
Workshop services  
Spare parts



Maintain your  
equipment to industry  
best practices



## Technical and economic optimization

Technical improvement  
Reliability increase  
Economic optimization



Get the most out of  
your assets



# Our comprehensive product portfolio

Power plant type	Applications							Hydraulic power recovery turbines
	Feedwater Pumps (FWP)	Condensate Extraction Pumps (CEP)	Cooling Water Pumps (CWP)	Heat Transfer Fluid pumps (HTF)	Nuclear safety pumps	Auxiliary pumps	Other power applications	
	Pump type							
	HPT GSG CP HPTd CD MD MC MBN MSD HZB BBS ZE PRE	SJD-CEP ZE PRE MC BBS	SJT-CWP SJT SMD HSA SMN ZPP	HZB-HTF BBS ZE/ZF OHH PRE	GSG GVG CP MSD HZB HSB ZFn REL SJT	AHLSTAR SNS CPE ZE/ZF OHH PRE SMD HSA SMN ZPP MC MBN SJT VMOA	VEY/VNY SJT-GEO SJD-CEP SJD-API HPDM	A good part of the pumps mentioned in this table can be used to capture energy as hydraulic power recovery turbines
Coal- and oil-fired power plants	●	●	●			●		
Gas-fired combined cycle power plant	●	●	●			●		
Nuclear power plant	●	●	●		●	●		
Biomass-fired power plant	●	●	●			●		
Solar thermal power plant	●	●	●	●		●	●	
Geothermal power plant		●	●			●	●	
Pumped-storage hydro power plant						●	●	●
Industrial power plant	●	●	●			●		
District heating plant						●		

# Product overview

## Barrel casing pumps

---

### HPT high pressure barrel casing pump

#### Features and benefits

- Design features to eliminate the need for pre-warming in most installations except on larger sizes
- Maximum safety due to double casing design
- Pipework connections remain undisturbed during disassembly
- High strength barrel material to accept thermal shock
- Full cartridge pull-out for rapid changeover
- Long operating life regardless of the operating mode

#### Applications

- Feedwater for TPP

#### Key characteristics

Capacities	up to 4'000 m <sup>3</sup> /h / 17'600 USgpm
Heads	up to 4'200 m / 13'800 ft.
Pressures	up to 545 bar / 7'905 psi
Temperatures	up to 220°C / 428°F

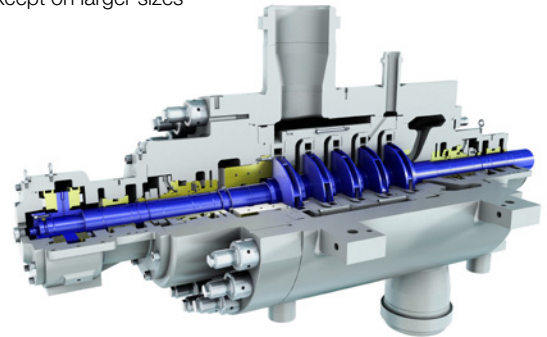

### GSG diffuser style barrel pump

#### Features and benefits

- Low-pressure, high-pressure, twistlock, and high-temperature designs suit many applications
- Direct drive options to 6 MW
- Back-to-back rotor stack option allows up to 16 stages
- Multiple sizes cover a broad hydraulic range

#### Applications

- Feedwater in fossil and industrial power plants
- Safety related services for NPP

#### Key characteristics

Capacities	up to 900 m <sup>3</sup> /h / 4'600 USgpm
Heads	up to 2'600 m / 10'000 ft.
Pressures	up to 300 bar / 4'500 psi
Temperatures	up to 425°C / 800°F

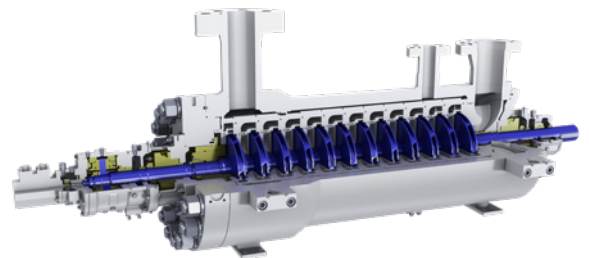

### CP volute style barrel pump

#### Features and benefits

- Opposed impellers balance axial thrust, without need of lube system on smaller pumps
- Axially split inner case means rotor balance is not disturbed when installed in the pump
- Dual volute inner case balances radial loads for longer service life
- Twistlock barrel closure reduces maintenance time on lower temperature services
- Cartridge design on larger pumps can speed up pump repair time
- Volute inner case with lower erosion wear on abrasive services

#### Applications

- Feedwater for industrial, biomass, CSP, TPP and CCPP
- Safety related services for NPP

#### Key characteristics

Capacities	up to 1'000 m <sup>3</sup> /h / 4'400 USgpm
Heads	up to 4'000 m / 13'120 ft.
Pressures	up to 425 bar / 6'250 psi
Temperatures	up to 425°C / 800°F

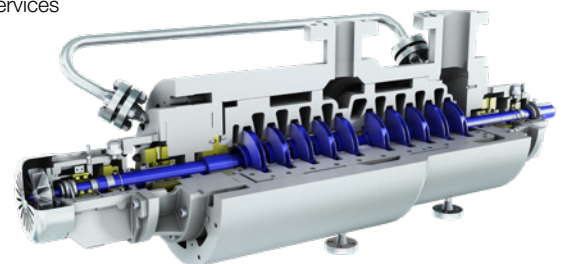

## GVG diffusor style barrel pump

### Features and benefits

- Low thrust bearing loads due to opposed impellers (even with worn clearances)
- Excellent rotordynamic behavior because of center bushing
- Forged barrel in chromium steel/austenitic stainless steel
- Full cartridge design to reduce downtime during maintenance
- Double suction impeller at first stage (optional)

### Applications

- Safety related services for NPP

### Key characteristics

Capacities	up to 65 m <sup>3</sup> /h / 285 USgpm
Heads	up to 1'900 m / 6'230 ft.
Pressures	up to 200 bar / 2'900 psi
Temperatures	up to 100°C / 212°F



## Ring section pumps

---

### MD high pressure stage casing pump

#### Features and benefits

- Modular hydraulics for high efficiency in a wide range of operating conditions
- Centerline mounted with large branch sizes for optimized inlet flow, low noise level and higher allowable forces and moments
- Unaffected by rapid temperature variations
- Stiff shaft design for critical speeds above the maximum operating speed
- Multiple screws mechanical tensioners are used on large sizes to allow simpler tightening and loosening

#### Applications

- Feedwater for industrial, biomass, CSP, TPP and CCPP

#### Key characteristics

Capacities	up to 1'200 m <sup>3</sup> /h / 5'300 USgpm
Heads	up to 2'800 m / 9'200 ft.
Pressures	up to 350 bar / 5'080 psi
Temperatures	up to 210°C / 410°F (higher temperature upon request)

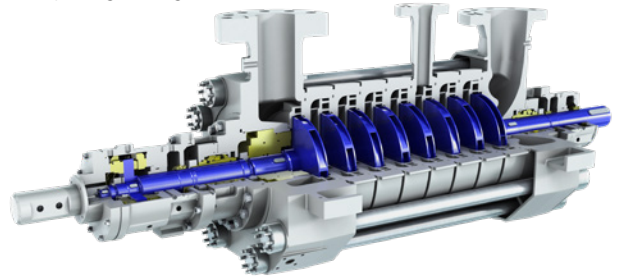

### MC high pressure stage casing pump

#### Features and benefits

- Modular hydraulics for high efficiency in a wide range of operating conditions
- Large branch sizes for optimized inlet flow, low noise level and higher allowable forces and moments
- Unaffected by rapid temperature variations
- Easy access for cleaning to the seal cooling chambers
- Stiff shaft design for critical speeds above the maximum operating speed
- Low pressure version with dedicated large sizes for condensate extraction service

#### Applications

- Feedwater for industrial, biomass, CSP and CCPP
- Fuel injection and NOx abatement in OCPP and CCPP
- Condensate extraction

#### Key characteristics

Capacities	up to 1'700 m <sup>3</sup> /h / 8'500 USgpm
Heads	up to 1'750 m / 5'500 ft.
Pressures	up to 180 bar / 2'610 psi
Temperatures	up to 180°C / 355°F

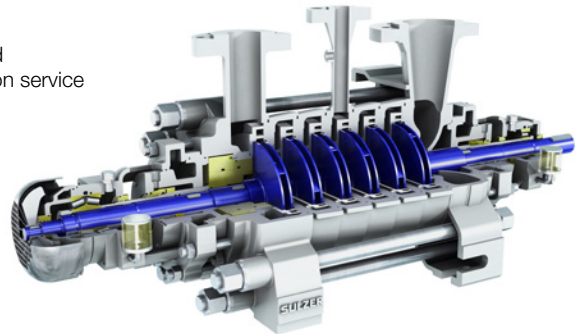

### MBN medium pressure stage casing pump

#### Features and benefits

- Simple construction to minimize dimensions and reduce investment and maintenance costs
- High quality investment cast impellers and diffusers for better efficiency
- Fast and easy impeller mounting
- Bearing unit can be serviced without disassembling the pump
- Wide range of materials including duplex stainless steel grades

#### Applications

- Feedwater for industrial and biomass power plants
- Auxiliary services
- District heating

#### Key characteristics

Capacities	up to 700 m <sup>3</sup> /h / 3'080 USgpm
Heads	up to 900 m / 2'950 ft.
Pressures	up to 140 bar / 2'030 psi
Temperatures	up to 180°C / 355°F

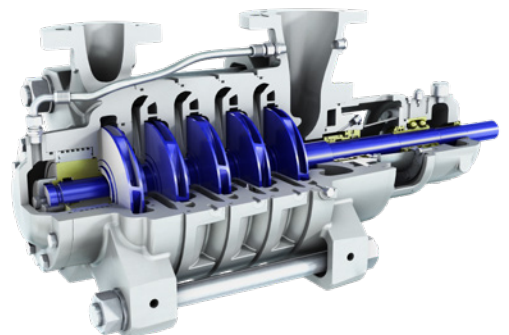



## Axially split pumps

---

### MSD axially split multistage pump

#### Features and benefits

- Broadest hydraulic coverage of any BB3 type multistage pump in the market
- Axially split casing means rotor balance is not disturbed when rotor is installed
- Opposed impellers balance axial thrust, saving lube system costs on most applications
- Double suction, first-stage available on most sizes for reduced Net Positive Suction Head (NPSH)

#### Applications

- Feedwater for industrial, biomass, CSP, TPP and CCPP
- Safety related services for NPP

#### Key characteristics

Capacities	up to 3'200 m <sup>3</sup> /h / 14'000 USgpm
Heads	up to 2'900 m / 9'500 ft.
Pressures	up to 300 bar / 4'400 psi
Temperatures	up to 200°C / 400°F

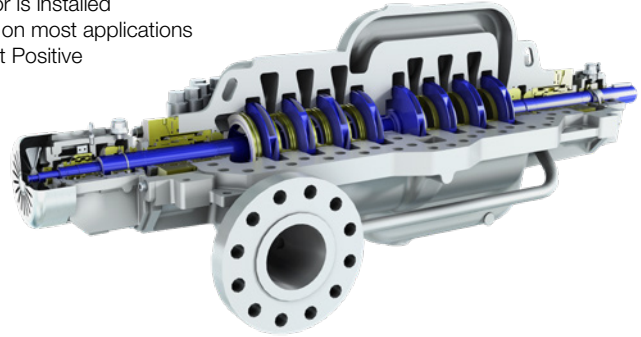

### HPDM axially split volute casing pump

#### Features and benefits

- Optimum technical solution due to a tailor-made design for each application
- Wide range of proven hydraulics allows high efficiency and outlet performance
- Robust design with generous safety margins for long life of reliable service with minimum maintenance

#### Applications

- Pump and hydro turbine for pumped storage power plants

#### Key characteristics

Capacities	up to 20'000 m <sup>3</sup> /h / 88'000 USgpm
Heads	up to 700 m / 2'300 ft.
Pressures	up to 175 bar / 2'500 psi
Temperatures	up to 70°C / 160°F

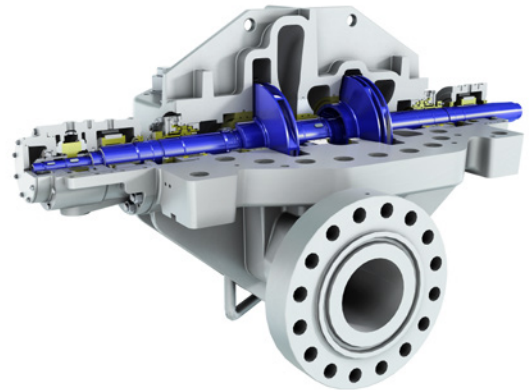

### SMD axially split casing double suction pump

#### Features and benefits

- Optimum hydraulic fit with high efficiency maintained over a wider flow range
- Exceptionally low Net Positive Suction Head Required (NPSHR) value not only at the best efficiency point but also on overload
- Maintenance-friendly features; excellent interchangeability of parts
- Horizontal and vertical constructions

#### Applications

- Cooling water pumps for CCPP, industrial, biomass and CSP
- Auxiliary services
- District heating

#### Key characteristics

Capacities	up to 25'000 m <sup>3</sup> /h / 110'000 USgpm
Heads	up to 260 m / 850 ft.
Pressures	up to 34 bar / 490 psi
Temperatures	up to 140°C / 280°F

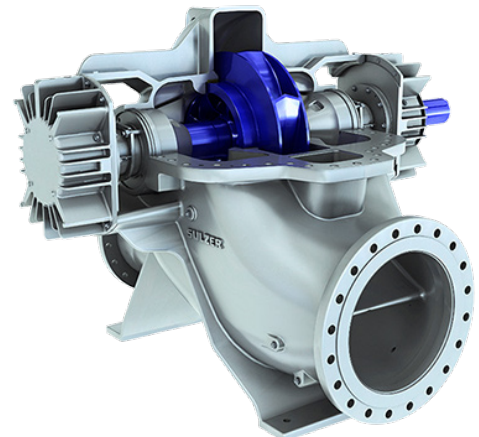

---

## HSA axially-split, single stage, double suction pump

### Features and benefits

- Double suction impeller with optimum geometry provides high efficiency, low NPSH, and quiet running over a wide operating range
- Large shaft diameter with minimum bearing span for more power capacity and longer mechanical seal life
- High capacity bearing assembly
- Horizontal and vertical construction

### Applications

- Cooling water pumps for CCPP, industrial, biomass and CSP
- Auxiliary services
- District heating

### Key characteristics

Capacities	up to 18'000 m <sup>3</sup> /h / 80'000 USgpm
Heads	up to 280 m / 900 ft.
Pressures	up to 40 bar / 580 psi
Temperatures	up to 150°C / 300°F

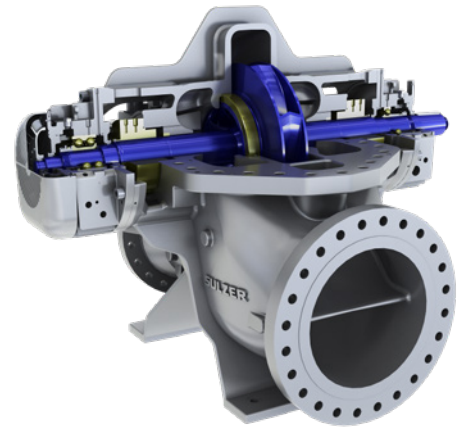

---

## SMN axially split casing double suction pump

### Features and benefits

- Broad hydraulic coverage through over 50 different sizes
- High efficiency
- Robust design for long service life
- Easy maintenance
- Flexible layout enabled by clockwise and counterclockwise rotation as well as vertical and horizontal arrangements

### Applications

- Cooling water pumps for CCPP, industrial, biomass and CSP
- Auxiliary services
- District heating

### Key characteristics

Capacities	up to 10'000 m <sup>3</sup> /h / 44'000 USgpm
Heads	up to 200 m / 650 ft.
Pressures	up to 30 bar / 435 psi
Temperatures	up to 150°C / 302°F



---

## ZPP double suction axially split single stage pump

### Features and benefits

- Exceeds requirements of international ISO 5199 standard
- Unique, patented and superior design features minimize life cycle costs
- Quick and easy installation, reliable operation, easy maintenance and service

### Applications

- Cooling water pumps for CCPP, industrial, biomass and CSP
- Auxiliary services
- District heating

### Key characteristics

Capacities	up to 25'000 m <sup>3</sup> /h / 110'000 USgpm
Heads	up to 160 m / 525 ft.
Pressures	up to 20 bar / 290 psi
Temperatures	up to 120°C / 250°F



---

## HSB horizontal axially split single stage between bearing pump

### Features and benefits

- Staggered vane, double suction impeller on larger sizes for reduced vibration
- Custom hydraulics to meet both current and future requirements with a simple rotor / volute changes
- Ball-ball, sleeve-ball and sleeve-pivot shoe bearings are available

### Applications

- Safety related services for NPP

### Key characteristics

Capacities	up to 10'000 m <sup>3</sup> /h / 45'000 USgpm
Heads	up to 550 m / 1'800 ft.
Pressures	up to 150 bar / 2'200 psi
Temperatures	up to 205°C / 400°F

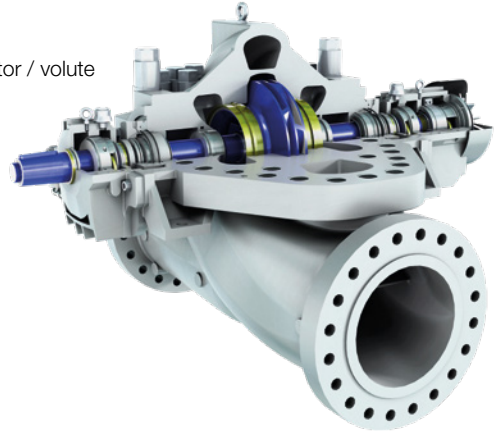

---

## Single stage pumps

### HPTd single stage double suction pump

#### Features and benefits

- Robust design to accept high piping loads
- Single cover design to reduce overhaul times
- Split bearing housings allow for bearing inspection without pump disassembly
- Single mechanical seal provides higher efficiency

#### Applications

- Feedwater for NPP

#### Key characteristics

Capacities	up to 5'000 m <sup>3</sup> /h / 22'000 USgpm
Heads	up to 800 m / 2'625 ft.
Pressures	up to 150 bar / 2'175 psi
Temperatures	up to 220°C / 428°F

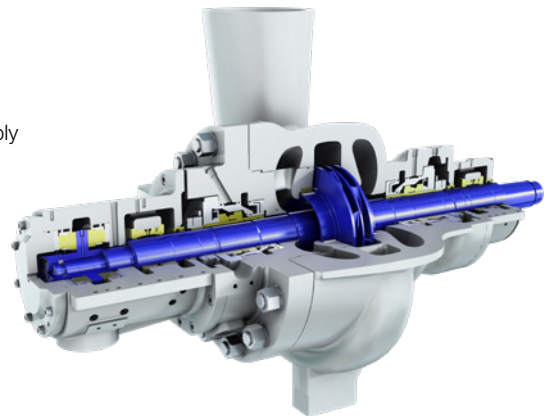

---

### HZB double suction volute pump

#### Features and benefits

- Centerline mounting to allow free thermal expansion and high nozzle loads
- Minimum bearing span to minimize shaft deflection
- Single cover casing design to reduce overhaul times
- Chrome steel casing with good corrosion resistance and excellent mechanical properties is standard, other materials available
- Single mechanical seal provides higher efficiency

#### Applications

- Feedwater booster for TPP and NPP
- Safety related services for NPP
- District heating

#### Key characteristics

Capacities	up to 5'500 m <sup>3</sup> /h / 29'000 USgpm
Heads	up to 340 m / 1'115 ft.
Pressures	up to 48 bar / 700 psi
Temperatures	up to 220°C / 428°F

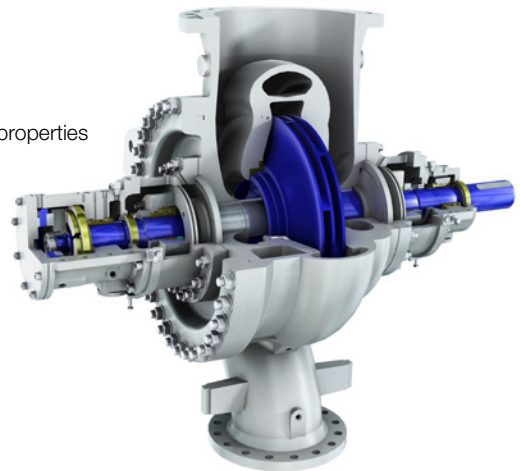

---

## BBS between bearings single stage pump

### Features and benefits

- Centerline support for reduced thermally induced misalignment
- Double suction impeller for low Net Positive Suction Head Required (NPSHR)
- First critical speed is well above operating speed range for smooth operation
- Casing designed for 2 times API 610 nozzle loads for freedom from piping distortions
- Grouted or ungrouted, 1x or 2x nozzle load baseplates for reduced installation cost

### Applications

- HTF oil for CSP
- Feedwater booster for TPP

### Key characteristics

Capacities	up to 5'000 m <sup>3</sup> /h / 22'000 USgpm
Heads	up to 450 m / 1'500 ft.
Pressures	up to 50 bar / 740 psi
Temperatures	up to 425°C / 800°F



---

## CD between bearings single stage pump

### Features and benefits

- Centerline support for reduced thermally induced misalignment
- Double suction impeller for low Net Positive Suction Head Required (NPSHR)
- First critical speed is well above operating speed range for smooth operation
- Casing designed for 2 times API 610 nozzle loads for freedom from piping distortions
- Grouted or ungrouted, 1x or 2x nozzle load baseplates for reduced installation cost

### Applications

- Feedwater for NPP
- Feedwater booster

### Key characteristics

Capacities	up to 7'000 m <sup>3</sup> /h / 30'000 USgpm
Heads	up to 800 m / 2'600 ft.
Pressures	up to 100 bar / 1'450 psi
Temperatures	up to 425°C / 800°F

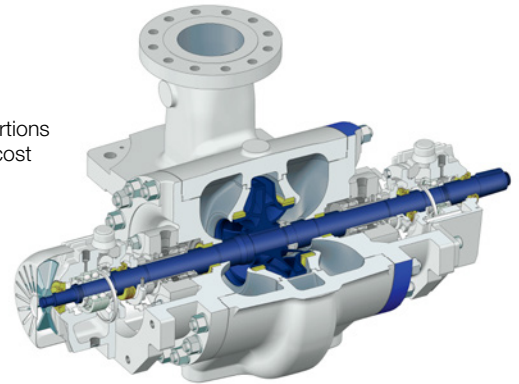

---

## HZB-HTF double suction volute pump

### Features and benefits

- Centerline mounting to allow free thermal expansion and high nozzle loads
- Minimum bearing span to minimize shaft deflection
- Single cover casing design to reduce overhaul times
- Carbon steel or chrome steel casing with excellent mechanical properties
- Double mechanical seal provides safer operation

### Applications

- HTF oil for CSP

### Key characteristics

Capacities	up to 4'000 m <sup>3</sup> /h / 17'500 USgpm
Heads	up to 340 m / 1'115 ft.
Pressures	up to 48 bar / 700 psi
Temperatures	up to 425°C / 800°F

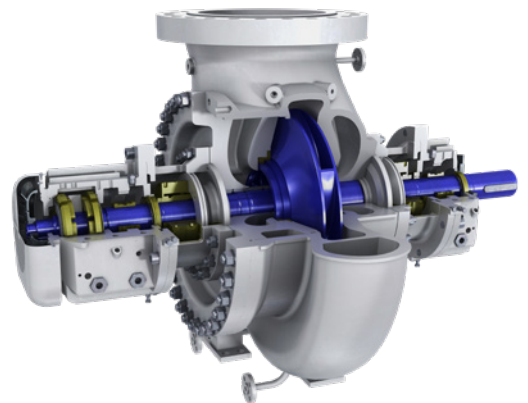

---

## ZE and ZF end suction pumps

### Features and benefits

- Designed for hot and cold process applications
- Modular construction to provide maximum interchangeability

### Applications

- Boiler feedwater booster
- Condensate extraction
- HTF oil for CSP
- Auxiliary services
- District heating

### Key characteristics

Capacities	up to 2'600 m <sup>3</sup> /h / 11'440 USgpm
Heads	up to 300 m / 1'000 ft.
Pressures	up to 100 bar / 1'450 psi
Temperatures	up to 425°C / 800°F

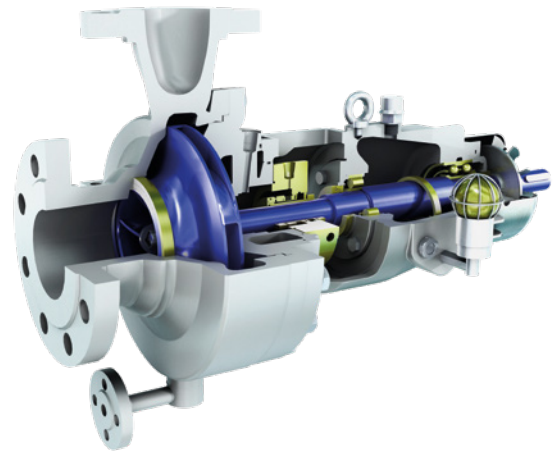

---

## OHH overhung single stage pump

### Features and benefits

- Finned bearing housing and fan cooling for long bearing life
- Broadest range map in the industry for ISO 13709 (API 610) type OH2 pumps
- Heavy duty baseplates with 2x ISO 13709 (API 610) nozzle load option
- ISO 21049 (API 682) cartridge type mechanical seals for reduced emissions
- Electric motor, Variable Frequency Drive (VFD), engine and steam turbine drivers

### Applications

- HTF oil for CSP
- Auxiliary services

### Key characteristics

Capacities	up to 2'250 m <sup>3</sup> /h / 10'000 USgpm
Heads	up to 360 m / 1'200 ft.
Pressures	up to 75 bar / 1'110 psi
Temperatures	up to 425°C / 800°F

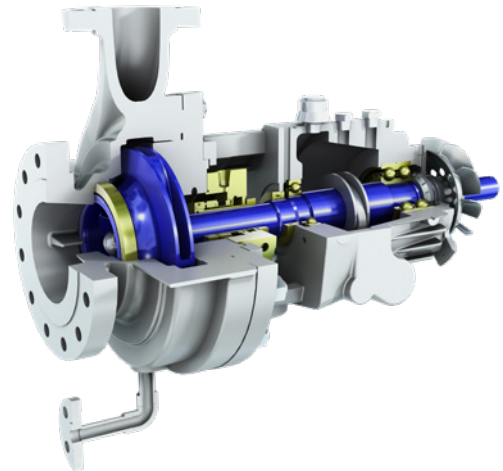

---

## PRE/PRER/PRETR end suction pumps

### Features and benefits

- Centerline mounted to allow thermal expansion without jeopardizing the shaft alignment
- Wear rings and balance holes optimized to maximize seal and bearing life
- Extra heavy-duty shaft for low shaft deflection and long life of seal and bearings
- PRER/PRETR reinforced designs available for very high pressure services (up to 200 bar)

### Applications

- Feedwater booster for TPP
- Condensate extraction
- Boiler circulation
- Auxiliary services
- HTF oil for CSP

### Key characteristics

Capacities	up to 4'500 m <sup>3</sup> /h / 19'800 USgpm
Heads	up to 320 m / 1'050 ft.
Pressures	up to 60 bar / 870 psi
Temperatures	up to 400°C / 752°F

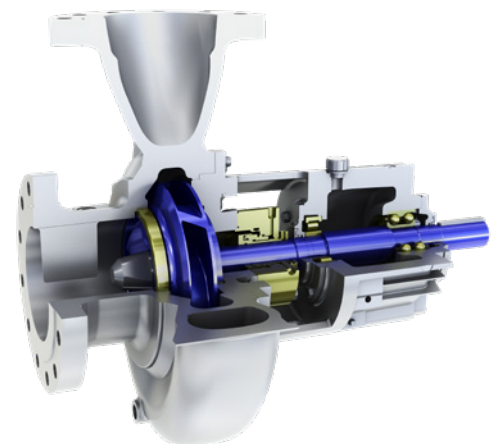

---

## AHLSTAR end suction single stage long coupled centrifugal pump

### Features and benefits

- Exceeds standard requirements of international ISO 5199 and ISO 2858 standards
- Suitable for the most demanding industrial applications
- Unique, patented and superior design features minimize life cycle costs
- Quick and easy installation, reliable operation, easy maintenance and service

### Applications

- Cooling water pumps for CCPP, industrial and biomass power plants
- Auxiliary services
- District heating

### Key characteristics

Capacities	up to 11'000 m <sup>3</sup> /h / 48'400 USgpm
Heads	up to 160 m / 525 ft.
Pressures	up to 25 bar / 360 psi
Temperatures	up to 180°C / 355°F

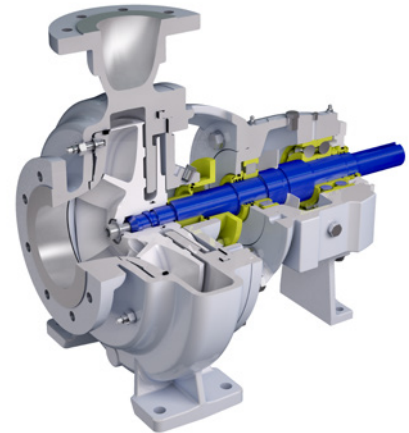

---

## CPE end suction single stage centrifugal pump

### Features and benefits

- Designed to exceed the strictest energy regulations for all the industries as well as the requirements of ASME B73.1
- Revolutionary hydraulics and high efficiency to offer the lowest life cycle costs
- Improved reliability
- Minimized total cost of ownership

### Applications

- Auxiliary services
- District heating

### Key characteristics

Capacities	up to 1'650 m <sup>3</sup> /h / 7'000 USgpm
Heads	up to 275 m / 900 ft.
Pressures	up to 27.5 bar / 400 psi
Temperatures	up to 260°C / 500°F

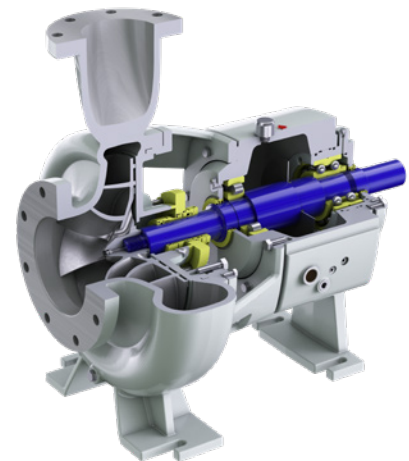

---

## SNS end suction single stage centrifugal pump

### Features and benefits

- Designed to meet the design requirement of EN ISO 5199 international standard
- Exceeding EU's (European Union) requirements for energy-related products (ErP)
- Highest efficiency across the whole pump range, exceeding the benchmark efficiency index MEI 0.7 (Minimum Efficiency Index)
- New, state-of-the-art hydraulics ensure optimum capacity with low net positive suction head required (NPSHr)
- Low energy consumption, high standardization, easy installation and unique construction also equate to lower maintenance and operating costs

### Applications

- Auxiliary services

### Key characteristics

Capacities	up to 1'400 m <sup>3</sup> /h / 6'000 USgpm
Heads	up to 160 m / 525 ft.
Pressures	up to 16 bar / 230 psi
Temperatures	up to 120°C / 250°F

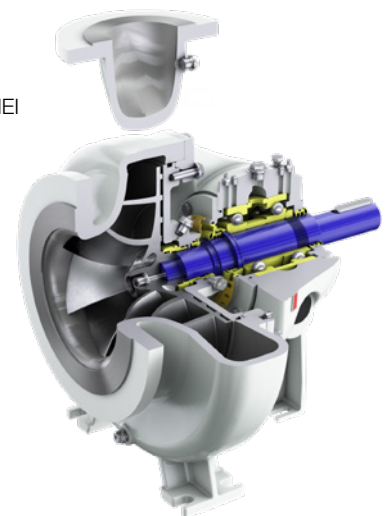

---

## ZFn horizontal volute type process pump

### Features and benefits

- Basic design according API 610 latest edition
- Casing designed for higher nozzle loads
- Proven hydraulic design from our API 610 pump range ZE/ZF
- Larger shaft diameter compared to API 610
- Reduced rotor bending
- Higher dry running critical speed
- Some sizes according to RCC-M codes

### Applications

- Safety related services for NPP

### Key characteristics

Capacities	up to 2'600 m <sup>3</sup> /h / 11'440 USgpm
Heads	up to 300 m / 1'000 ft.
Pressures	up to 100 bar / 1 450 psi
Temperatures	up to 425°C / 800°F

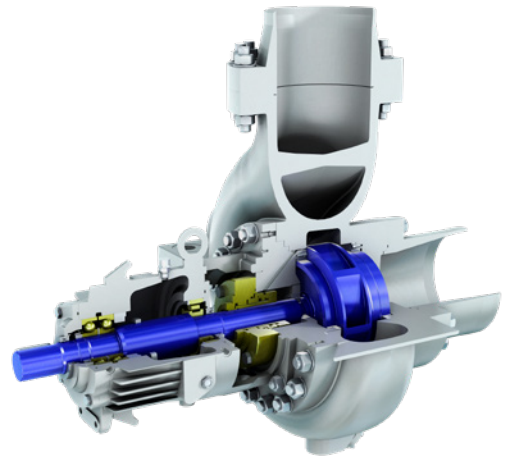

---

## REL horizontal diffuser style single stage pump

### Features and benefits

- Casing designed for higher nozzle loads
- Proven hydraulic design from our API 610 pump range ZE/ZF
- Larger shaft diameter compared to API 610
- Reduced rotor bending
- Higher dry running critical speed
- Some sizes according to RCC-M codes

### Applications

- Safety related services for NPP

### Key characteristics

Capacities	up to 2'600 m <sup>3</sup> /h / 11'440 USgpm
Heads	up to 300 m / 1'000 ft.
Pressures	up to 100 bar / 1'450 psi
Temperatures	up to 425°C / 800°F

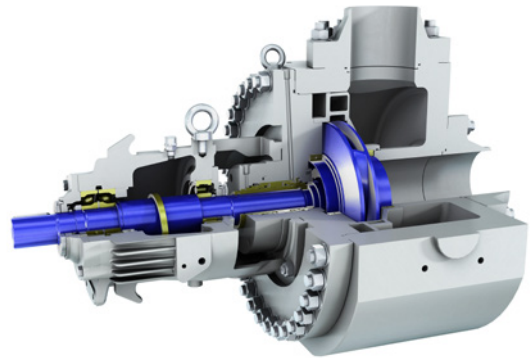

---

## VMOA transformer oil circulation pump

### Features and benefits

- Excellent performance
- Suitable for transformer oil cooling systems
- Unique design features minimize life-cycle costs
- Quick and easy installation, safe operation, maintenance free

### Applications

- Clean transformer oil

### Key characteristics

Capacities	up to 115 m <sup>3</sup> /h / 500 USgpm
Heads	up to 13 m / 40 ft.
Pressures	up to 10 bar / 145 psi
Temperatures	up to 100°C / 210°F

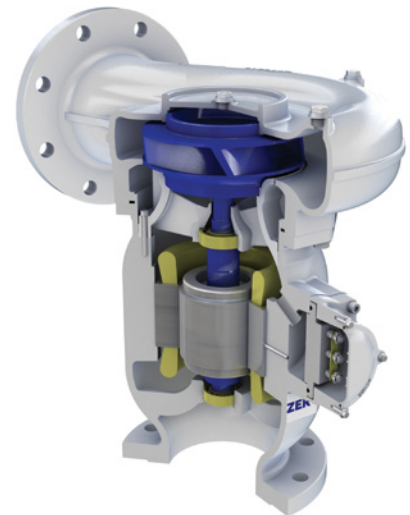

## Vertical pumps

---

### SJD-CEP vertical can mounted turbine type pump

#### Features and benefits

- Carbon graphite product lubricated bearing in bowls and columns for long maintenance-free periods
- Removable seal housing allows servicing throttle bushing without removing the head
- Separate fabricated driver stand allows using one suction and discharge head per pump size
- Spacer coupling allows servicing the mechanical seal and thrust bearing as needed
- Can is provided with lateral and anti-rotational ribs uniform inlet velocity along the can length
- Various options available for the first stage impeller hydraulics, including double suction impeller allowing optimum sizing of pump

#### Applications

- Condensate extraction for CSP, CCGP, TPP and NPP
- Heater drain for TPP and NPP
- Organic fluid feed for geothermal power plants

#### Key characteristics

Capacities	up to 4'900 m <sup>3</sup> /h / 21'560 USgpm
Heads	up to 470 m / 1'540 ft.
Pressures	up to 47 bar / 680 psi
Temperatures	up to 100°C / 212°F



### SJD-API vertically suspended process pump

#### Features and benefits

- Reduced number of stages results in shorter and more reliable pumps
- Double suction first stage impeller on larger sizes can reduce pump length
- High efficiency with reduced power consumption
- Modular construction to fit project nozzle location requirements
- High head per stage means process conditions can be reached with slower speeds

#### Applications

- Organic fluid feed for geothermal power plants

#### Key characteristics

Capacities	up to 3'800 m <sup>3</sup> /h / 20'000 USgpm
Heads	up to 700 m / 3'000 ft.
Pressures	up to 75 bar / 1'100 psi
Temperatures	up to 205°C / 400°F



### SJT-CWP vertical pump

#### Features and benefits

- Modern fabricated suction bell and bowl casing incorporating swirl break for stable pump performance curve
- Semi-open or closed cast impeller design for best fitting and optimum efficiency
- Segmented elbow to reduce the internal losses
- Optional full pull-out construction to reduce lifting crane capacity and ease maintenance

#### Applications

- Cooling water pumps for CCGP, TPP and NPP

#### Key characteristics

Capacities	up to 90'000 m <sup>3</sup> /h / 396'000 USgpm
Heads	up to 60 m / 200 ft.
Pressures	up to 8.6 bar / 125 psi
Temperatures	up to 50°C / 122°F

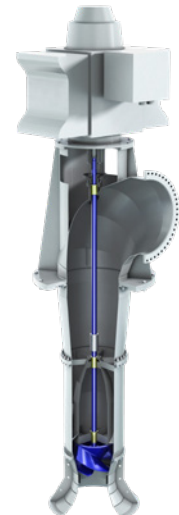



---

## SJT vertical pump

### Features and benefits

- Optimized hydraulics for high efficiency
- Packed stuffing box for reliable sealing and simple maintenance; mechanical seal available as an option
- Rubber-lined product-lubricated bearing in bowls and columns for long maintenance-free periods; other bearing materials are also available
- Optional spacer coupling allows servicing of seal and thrust bearing as required

### Applications

- Cooling water pumps
- Safety related services
- Auxiliary services

### Key characteristics

Capacities	up to 12'000 m <sup>3</sup> /h / 52'840 USgpm
Heads	up to 1'830 m / 6'000 ft.
Pressures	up to 78 bar / 1'130 psi
Temperatures	up to 100°C / 212°F

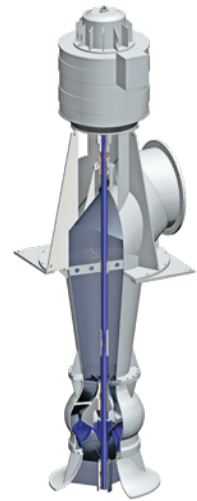

---

## VEY and VNY vertical turbine pumps

### Features and benefits

- Engineered suction design for optimized submergence
- Engineered bearing bushings for better shaft alignment and adaptation to the thermal expansion
- Main shaft sealing by throttle bushing for permanent leak-off recirculation to the molten salt tank
- Auxiliary shaft sealing deflector preventing leakage of molten salt to the atmosphere
- Efficient thermal barrier between hot/cold sections
- Muff coupling to ease dismantling
- Special design to allow thermal expansions: extended wear ring zone and clearances calculated considering all the relative expansions

### Applications

- Molten salt for CSP

### Key characteristics

Capacities	up to 4'000 m <sup>3</sup> /h / 17'600 USgpm
Heads	up to 380 m / 1'250 ft.
Pressures	up to 100 bar / 1'450 psi
Temperatures	up to 600°C / 1'100°F



---

## SJT-GEO production hot water pump

### Features and benefits

- Increased flow for higher geothermal hot water production capacity of 13 3/8" wells
- Increased power transmission capability
- Increased temperature for high enthalpy geothermal resources
- Water lubricated bearings or oil recovery system to protect environment
- Up to 5.5" end-play axial float for shaft adaptation to shallow geothermal wells

### Applications

- Production hot water for geothermal power plants

### Key characteristics

Capacities	up to 680 m <sup>3</sup> /h / 3'000 USgpm
Heads	up to 700 m / 2'300 ft.
Pressures	up to 100 bar / 1'450 psi
Temperatures	up to 220°C / 428°F



---

## Hydraulic power recovery turbine

Hydraulic turbines come in various shapes and sizes. For higher flows, centrifugal pumps in reverse rotation are efficiently used as HPRTs. For high flows and lower pressure differential, mixed flow, or axial flow (propeller) type vertical pumps may be used as HPRTs. The standard MSD, HSB, GSG, HPDM, MC, MD, and many other pumps can all be modified to capture energy as an HPRT.

### Features and benefits

- Convert the excess pressure into mechanical shaft energy and increase the overall process efficiency
- Low investment costs compare to conventional turbines
- Economical solution for pressure reduction in industrial processes
- Can provide substantial savings with a short payback period

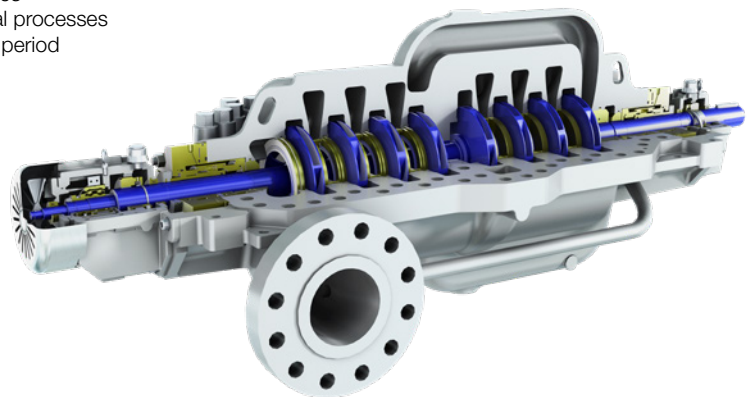

---

### List of acronyms used in the product overview

CCPP = Combined-Cycle Power Plant  
CSP = Concentrated Solar Power  
NPP = Nuclear Power Plant  
OCPP = Open Cycle Power Plant  
TPP = Thermal Power Plant



**The Sulzer Flow division keeps your processes flowing. Wherever fluids are treated, pumped, or mixed, we deliver highly innovative and reliable solutions for the most demanding applications.**

---

The Flow division specializes in pumping solutions specifically engineered for the processes of our customers. We provide pumps, agitators, compressors, grinders, screens and filters developed through intensive research and development in fluid dynamics and advanced materials. We are a market leader in pumping solutions for water, oil and gas, power, chemicals and most industrial segments.

---

E00643 en 12.2024, Copyright © Sulzer Ltd 2024

This brochure is a general presentation. It does not provide any warranty or guarantee of any kind. Please, contact us for a description of the warranties and guarantees offered with our products. Directions for use and safety will be given separately. All information herein is subject to change without notice.

