

No: M-14.0260 - 07

Dat/Nam.: 11.03.2016 / J. Beste

Cad Code: M_140260

Technical changes reserved
 Änderungen vorbehalten
 Sous réserve de modifications

RCP500

Dimension sheet RCP500

Maßblatt RCP500

Plan d'encombrement RCP500



Type Typ Type	Type Typ Type	Weight Gewicht Poids		X		Y	
		(~kg)	(~lb)	(mm)	(inch)	(mm)	(inch)
50Hz	60Hz						
A 50/12	A 60/12	215	474	447	17.6	865	34.1
A 75/12	A 90/12	250	551	520	20.5	1005	39.6
A 100/12	A 120/12	255	562	520	20.5	1005	39.6

Weight: Includes pump, slider bracket and 10m cable
 Gewicht: Beinhaltet Pumpe, Halterung und 10m Kabel
 Poids: Pompe, coulisseau et 10m de câble

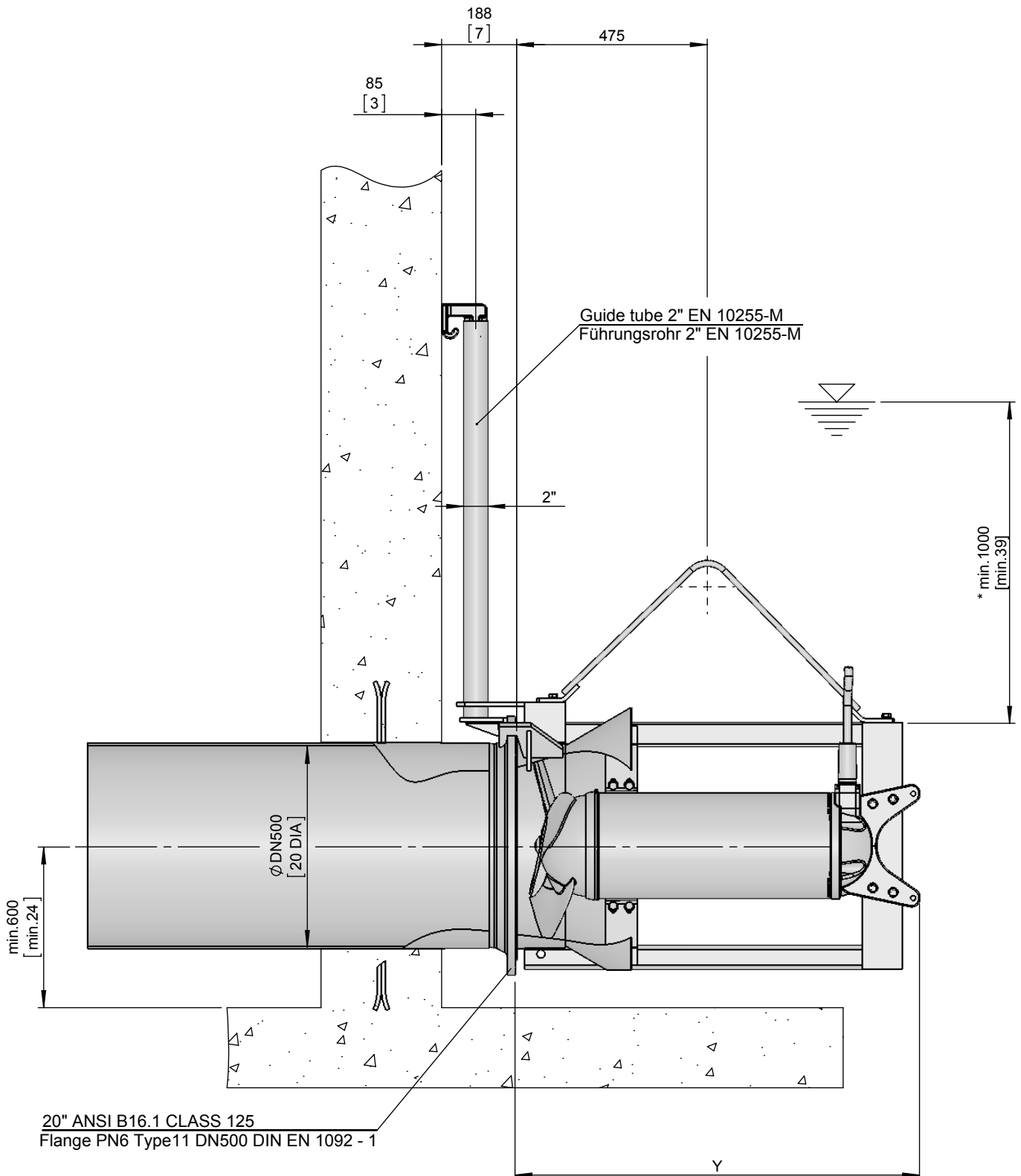

*Guideline value: Minimum submergence can be lower
 Richtwert: Die Mindestüberdeckung kann geringer sein
 Valeur indiquée: la submergence minimale peut s'avérer inférieure en pratique

No: M-14.0272 - 05
 Dat/Nam.: 09.01.2015 / L.Henrich
 Cad Code: M_140272
 Technical changes reserved
 Änderungen vorbehalten
 Sous réserve de modifications

RCP500

Dimension sheet RCP500

Maßblatt RCP500

Plan d'encombrement RCP500



Type Typ Type	Type Typ Type	Weight Gewicht Poids		Y	
		(~kg)	(~lb)	(mm)	(inch)
50Hz	60Hz				
A 50/12	A 60/12	215	474	865	34.1
A 75/12	A 90/12	250	551	1005	39.6
A 100/12	A 120/12	255	562	1005	39.6

Weight: Includes pump, slider bracket and 10m cable
 Gewicht: Beinhaltet Pumpe, Halterung und 10m Kabel
 Poids: Pompe, coulisseau et 10m de câble

ANSI

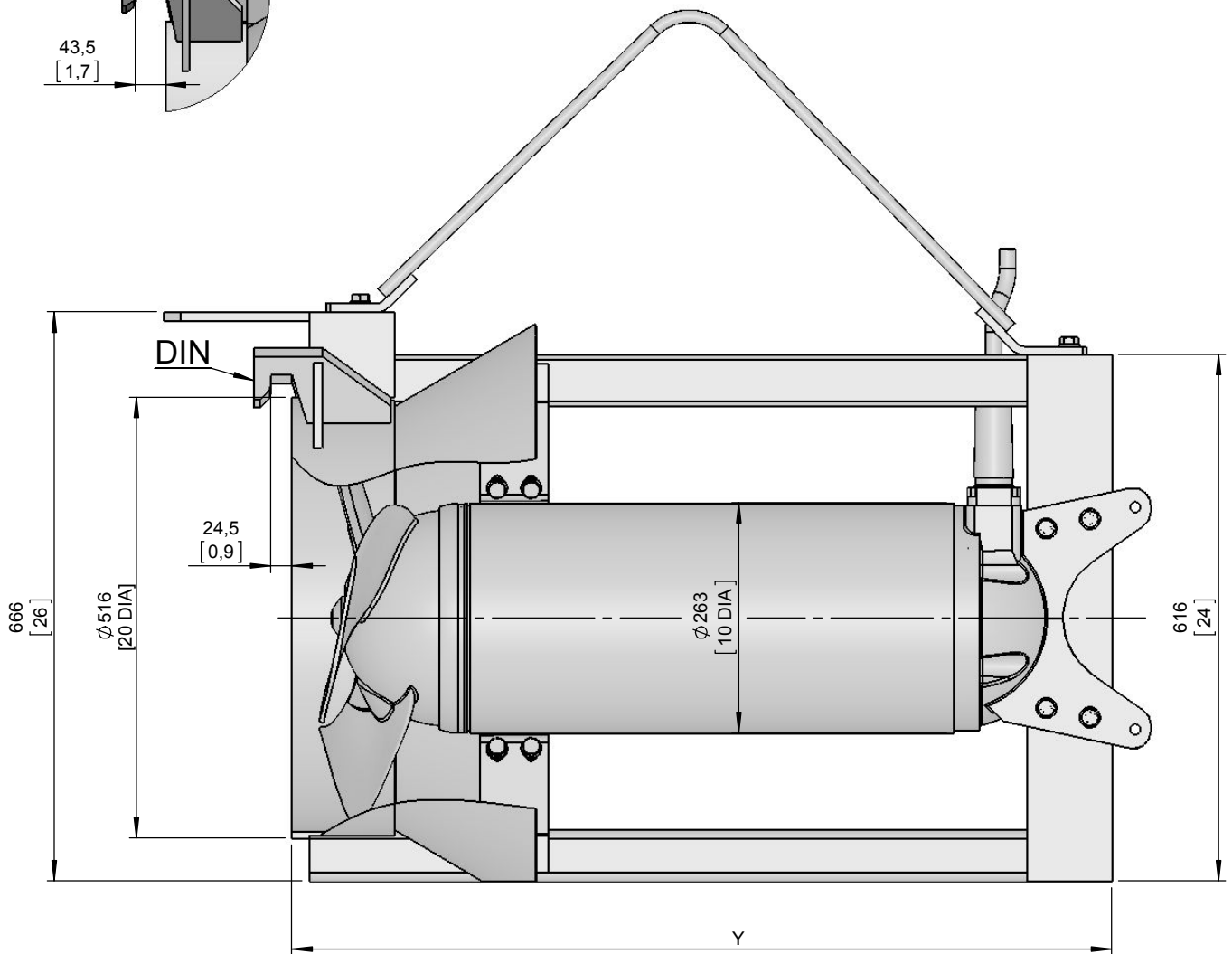
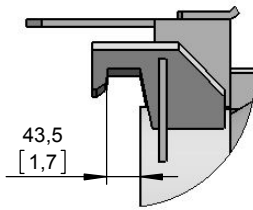

[mm
[inch]