

Cutting-edge pumping solutions for the nuclear power industry





The Sulzer advantage

Safe operation and plant reliability are key focuses of the nuclear power generation industry. With years of experience in the field, Sulzer is able to provide the right pumping solutions contributing to safer and more efficient operations.

Reliability

- Reliability and safety are paramount of nuclear power generation processes
- In their search for reliable solutions, nuclear power operators have successfully turned to Sulzer, be it for new pumping equipment, servicing or repairs

Efficiency

- Striving at making our customers more efficient and costs competitive, Sulzer utilizes the most advanced technology to elaborate a highly reliable pumping solution
- To minimize life cycle costs and optimize performance, Sulzer develops solutions tailored to the customers' needs and requirements for a perfect fit

Experience and know-how

- Because technical errors can have dramatic consequences, it is crucial to rely on proven solutions when it comes to nuclear. Sulzer, through more than 40 years, has equipped nuclear plants with efficient pumping solutions worldwide
- From development to implementation and servicing, Sulzer, thanks to its complete portfolio, is your single-source provider for nuclear power plants

Qualifications and certificates

All Sulzer manufacturing plants design, produce and test vertical and horizontal pumps dedicated to nuclear and turbine island applications.

- ASME Section III (Cl. 1, 2 & 3)
- ASME N & NPT certificate of authorization
- CSA B51
- CSA N285
- MIL-Q-9858-A
- NDT (MPI/LPI/RT/UT)
- EN 13445
- CSA Z299.1/2/3/4
- Standard KTA 1401
- IAEA 50-C-Q
- AVS D 100/50
- FRA/N/100/OL3
- RCC-M
- API 610, ISO 5199, ANSI/ASME B73.1
- HAF 601 CL. 3
- HAF 604 CL. 2 & 3

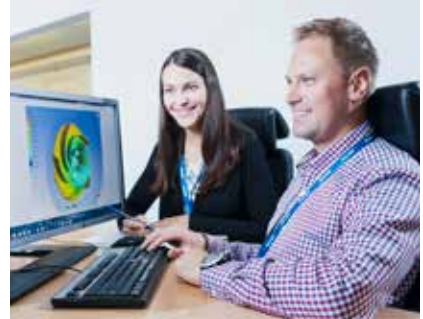

Whatever the process, we have the pumping solutions

Pressurized water reactor with active safety

In a pressurized water reactor, the primary coolant is pumped under high pressure to the reactor core; the superheated water then transfers thermal energy to a steam generator. The pressurized water reactor turbine cycle loop is separated from the primary loop, so the water in the secondary loop is not contaminated by radioactive materials. Direct descendants of previous models, pressurized water reactors are classified as generation III+ due to the level of safety and greater fuel efficiency they achieve in relation to earlier models.

The active safety pressurized water reactors have several active and passive protection measures against accidents and redundant independent emergency cooling systems, each capable of cooling down the reactor after shutdown.

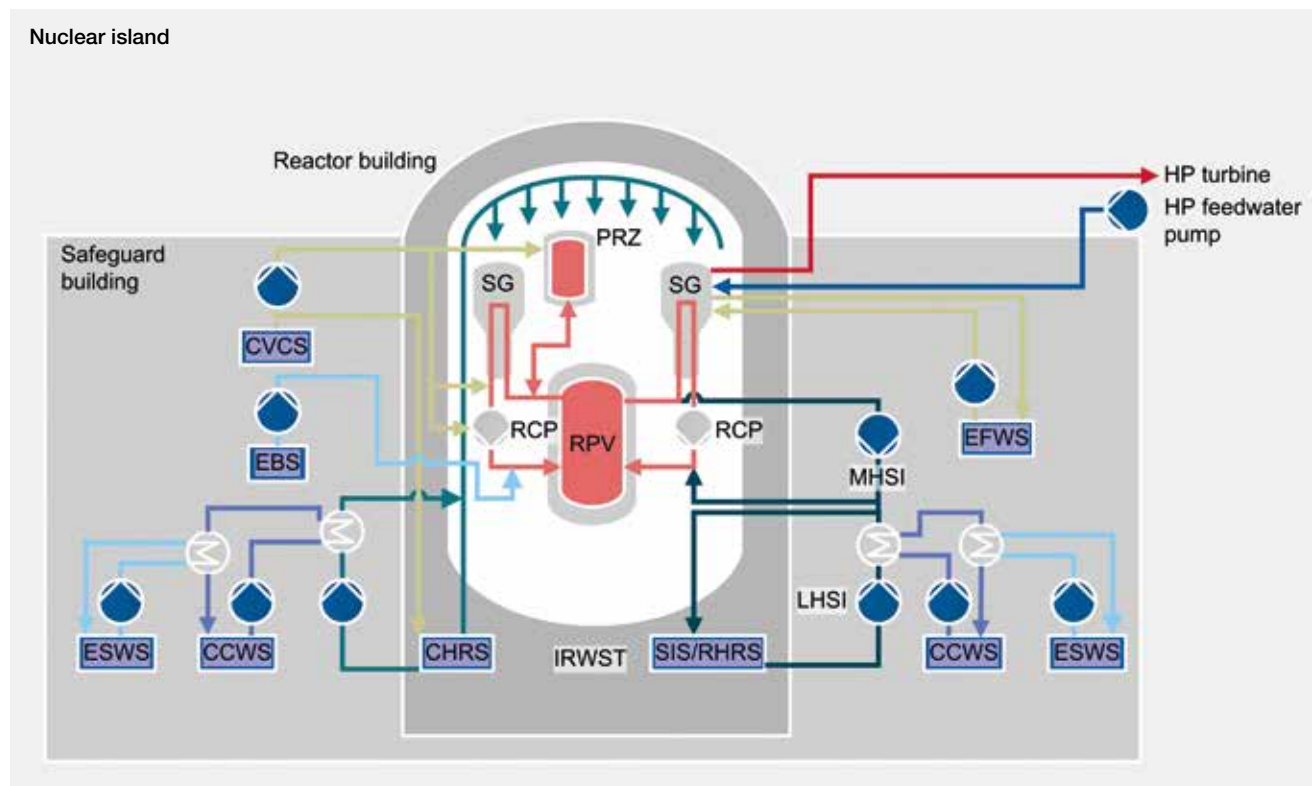

- PRZ = Pressurizer
- SG = Steam Generator
- RCP = Reactor Coolant Pump
- RPV = Reactor Pressure Vessel
- CVCS = Chemical Volume & Control System
- MHSI = Medium Head Safety Injection
- EBS = Extra Borating System
- ESWS = Essential Service Water System
- CCWS = Component Cooling Water System
- EFWS = Emergency Feedwater System
- LHSI = Low Head Safety Injection
- CHRS = Containment Heat Removal System
- IRWST = In-Containment Refueling Water Storage Tanks
- SIS/RHRS = Safety Injection System/Residual Heat Removal System

Pressurized water reactor with passive safety

The major difference compared with the active safety pressurized water reactor design is that it has fewer safety pumps due to its passive (gravity) safety system. The Passive Core Cooling System (PCCS) uses both explosively operated and direct current valves which must activate within the first 30 minutes. The design is intended to passively remove heat for 72 hours after which the Passive Core Cooling Water System Tank (PCCWST) gravity drain water tank with active safety must be topped up for as long as cooling is required.

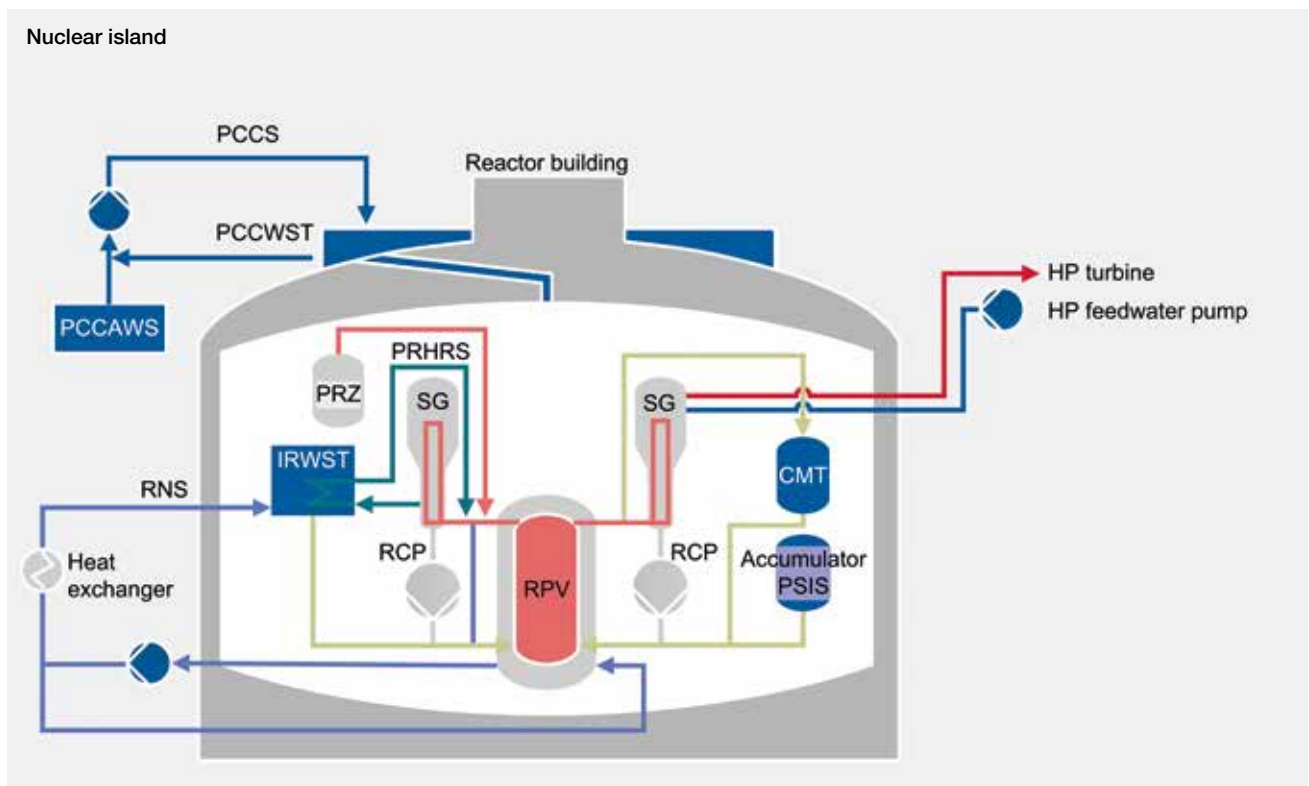

HP	= High Pressure
PRZ	= Pressurizer
SG	= Steam Generator
RCP	= Reactor Coolant Pump
RPV	= Reactor Pressure Vessel
PCCS	= Passive Core Cooling System
PCCWST	= Passive Core Cooling Water System Tank
PCCAWS	= Passive Core Cooling Auxiliary Water System
PRHRS	= Pressurizer Heat Removal System
RNS	= Normal Residual Heat Removal System
IRWST	= In-Containment Refueling Water Storage Tank
CMT	= Core Make-up Tank

Boiling water reactor

The generation III+ boiling water reactor is the current state-of-the-art in boiling water reactors. The reactor vessel and associated components operate at a substantially lower pressure (about 75 bar) compared to a pressurized water reactor (about 158 bar). It also operates at a lower nuclear fuel temperature and can operate at lower core power density levels using natural circulation without forced flow. A boiling water reactor may be designed to operate using only natural circulation so that recirculation pumps are eliminated entirely.

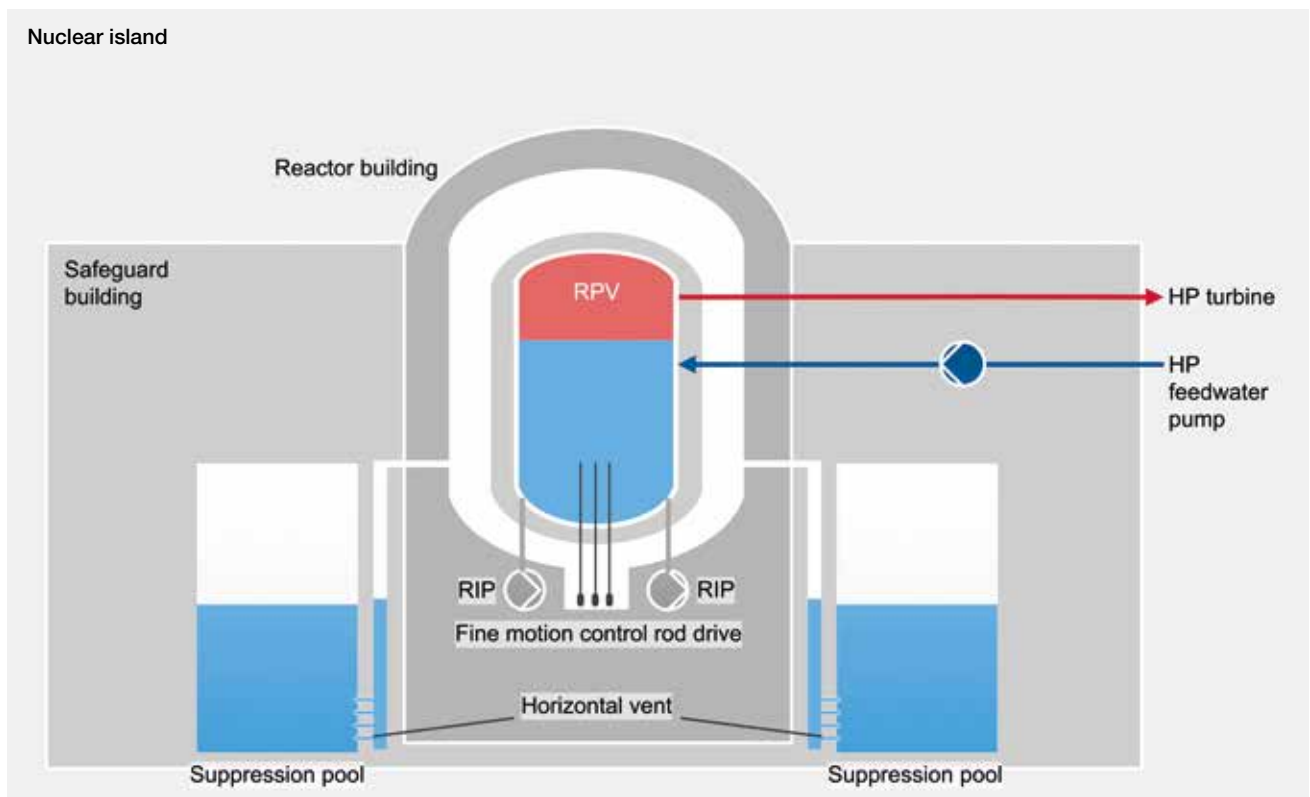

HP = High Pressure Feedwater Pump
RIP = Reactor Internal Pump
RPV = Reactor Pressure Vessel

Pressurized heavy water reactor

The pressurized heavy water reactor is a generation III heavy-water moderated and heavy-water cooled pressure tube reactor. It is one of the most efficient moderators and enables the use of natural uranium as fuel. The use of natural uranium increases a country's energy independence as fuel can be manufactured locally.

With latest technological advances, some reactors are now able to use alternative fuels such as recycled uranium, resulting in a better management of uranium resources usage as well as fuel costs savings for the utility.

Heavy water coolant passes through the reactor core and removes the heat generated by the fission chain reactions. This heated reactor coolant heats light (ordinary) water and converts it to steam, which drives a turbine-generator to produce electricity.

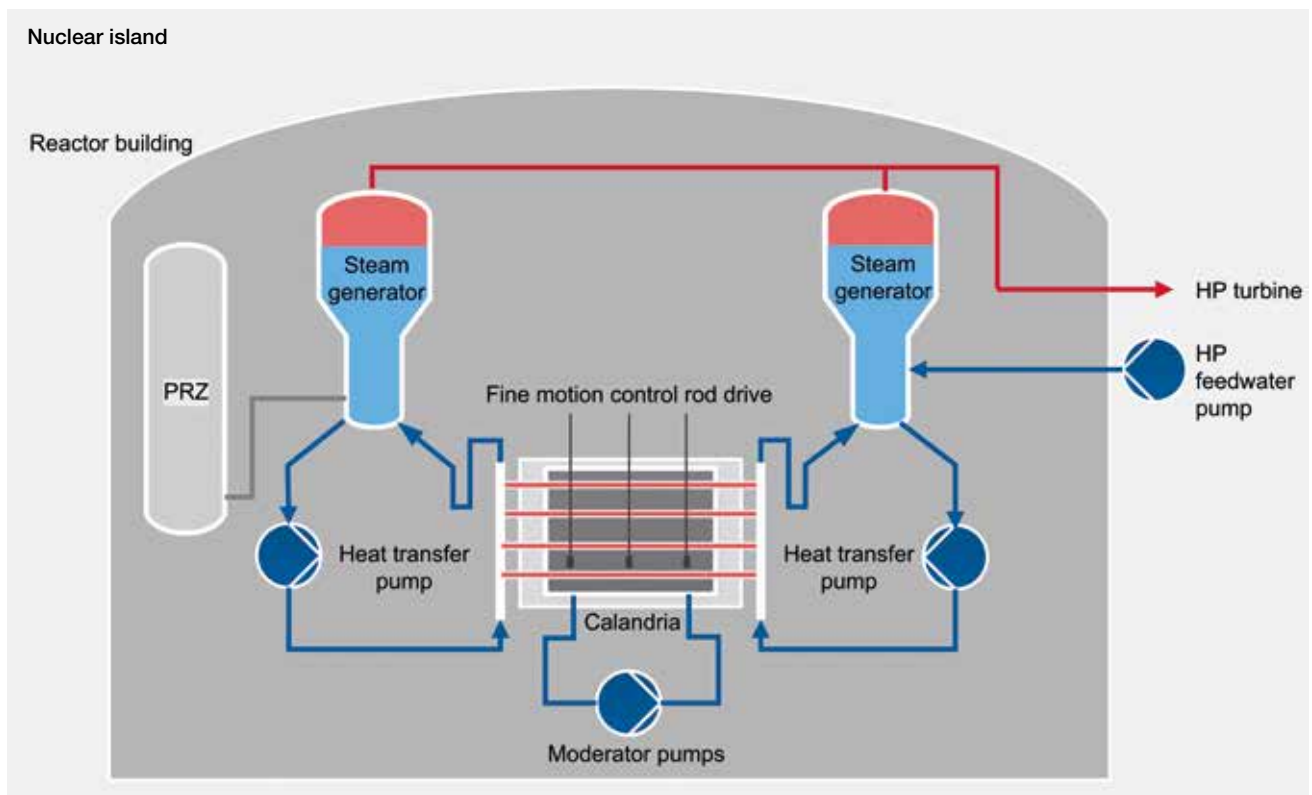

HP = High Pressure Feedwater Pump
PRZ = Pressurizer

Turbine island

Similar to conventional power stations, in the turbine island of a nuclear power plant, the heat generated by fission of enriched uranium in the nuclear reactor is used to generate steam which drives a steam turbine connected to a generator which produces electricity.

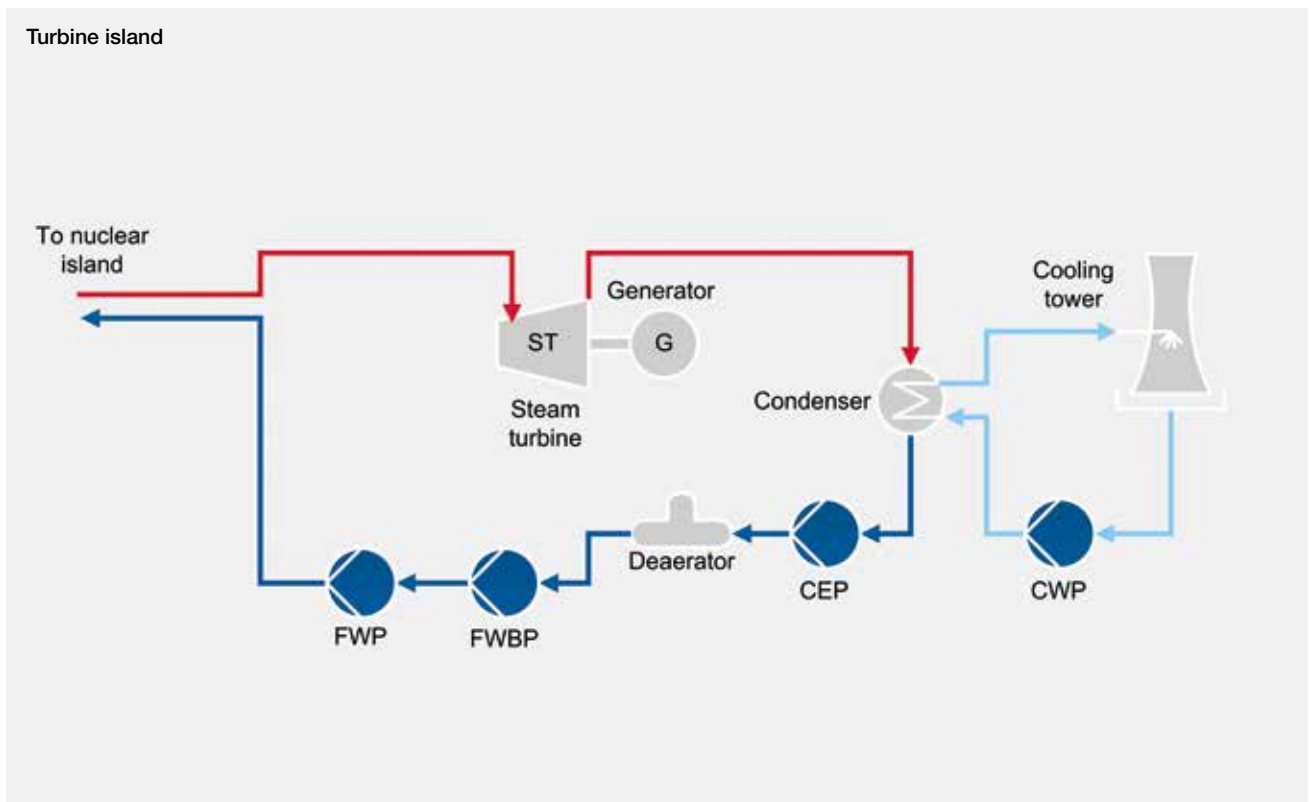

FWP = Feedwater Pump
FWBP = Feedwater Booster Pump
CEP = Condensate Extraction Pump
CWP = Cooling Water Pump

Our comprehensive product portfolio

For more than 60 years, Sulzer has been a major player in the nuclear industry and successfully supplied critical pumps for many projects worldwide. The design and manufacturing of our pumps are carried out according to commonly used international standard and design codes. Sulzer has in-depth knowledge and experience of ASME Sec III (Class 1,2, 3, and NC incl. N-stamp), CSA N.285.0, RCC-M and EN codes for the supply of nuclear pumps. Pumps for non-safety related applications are designed according to API 610 or exceeding requirements of ISO 5199 and ANSI/ASME B73.1.

Nuclear reactor type	Pump types available for the nuclear island applications				
	GVG GSG CP	MSD HSB	HZB CD ZFn REL OHH	SJT/SJM	VCR
Pressurized water reactor with active safety	✓	✓	✓	✓	✓
Pressurized water reactor with passive safety	✓	✓		✓	
Boiling water reactor		✓		✓	✓
Pressurized heavy water reactor		✓	✓	✓	

Applications in the turbine island				
Feedwater Booster Pumps (FWBP)	Feedwater Pumps (FWP)	Condensate Extraction Pumps (CEP)	Cooling Water Pumps (CWP)	Auxiliary pumps
Pump types available for the turbine island applications				
HZB	HPTd CD	SJD (CEP)	SJT/SJM CWP SJT/SJM	AHLSTAR CPE OHH SMD SMN CZ/ZA/ZE/ZF SJT/SJM
✓	✓	✓	✓	✓

Product overview for nuclear island

Barrel pumps

GVG diffuser style barrel pump

Features and benefits

- Low thrust bearing loads due to opposed impellers (even with worn clearances)
- Excellent rotordynamic behavior because of center bushing
- Forged barrel in chromium steel/austenitic stainless steel
- Full cartridge design to reduce downtime during maintenance
- Double suction impeller at first stage (optional)

Applications

- Control rod drive pump
- High pressure charging pump
- Make up water pump

Key characteristics

Capacities	up to 65 m ³ /h / 285 USgpm
Heads	up to 1'900 m / 6'230 ft.
Pressures	up to 200 bar / 2'900 psi
Temperatures	up to 100°C / 212°F



GSG diffuser style barrel pump ISO 13709 / API 610 BB5

Features and benefits

- Most cost-efficient form of ISO 13709 / API 610 type BB5 high-pressure barrel pumps
- In-line and opposed impeller (back-to-back) design available
- Direct drive options up to 6 MW
- Back-to-back rotor stack allows up to 16 stages
- Multiple sizes cover a broad hydraulic range
- Low-pressure, high-pressure, and high-temperature designs suit many applications

Applications

- Safety related services
- Emergency feedwater pump
- Low head safety injection pump
- Medium head safety injection pumps

Key characteristics

Capacities	up to 900 m ³ /h / 4'600 USgpm
Heads	up to 2'600 m / 10'000 ft.
Pressures	up to 300 bar / 4'500 psi
Temperatures	up to 425°C / 800°F

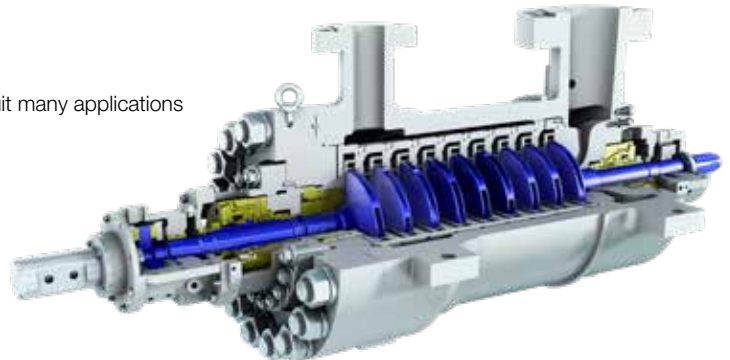

CP volute style barrel pump

Features and benefits

- Opposed impellers balance axial thrust, without need of lube system on smaller pumps
- Axially split inner case means rotor balance is not disturbed when installed in the pump
- Dual volute inner case balances radial loads for longer service life
- Twistlock barrel closure reduces maintenance time on lower temperature services
- Cartridge design on larger pumps can speed up pump repair time
- Volute inner case with lower erosion wear on abrasive services

Applications

- Safety related services

Key characteristics

Capacities	up to 1'000 m ³ /h / 4'400 USgpm
Heads	up to 7'000 m / 23'000 ft
Pressures	up to 425 bar / 6'250 psi
Temperatures	up to 425°C / 800°F

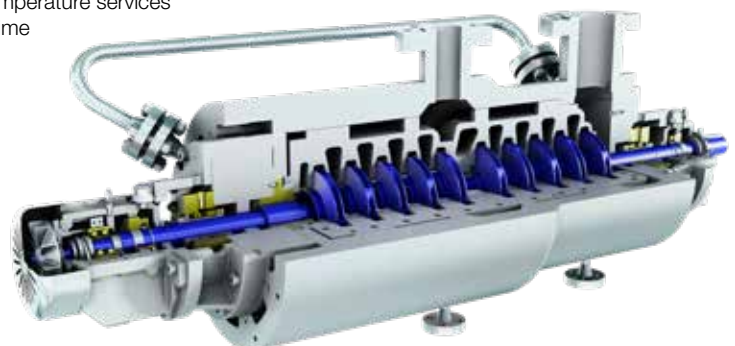

Axially split pumps

MSD axially split multistage pump

Features and benefits

- Broadest hydraulic coverage of any BB3 type multistage pump in the market
- Axially split casing means rotor balance is not disturbed when rotor is installed
- Opposed impellers balance axial thrust, saving lube system costs on most applications
- Double suction, first-stage available on most sizes for reduced Net Positive Suction Head (NPSH)

Applications

- Safety related services

Key characteristics

Capacities	up to 3'200 m ³ /h / 14'000 USgpm
Heads	up to 2'900 m / 9'500 ft.
Pressures	up to 300 bar / 4'400 psi
Temperatures	up to 200°C / 400°F

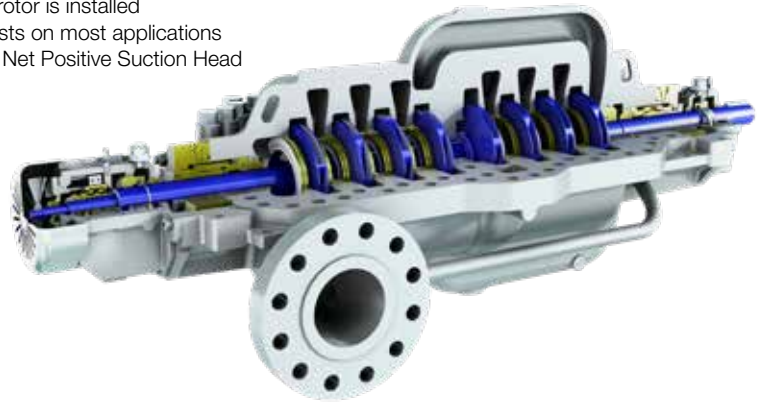

HSB horizontal axially split single stage between bearing pump

Features and benefits

- Staggered vane, double suction impeller on larger sizes for reduced vibration
- Custom hydraulics to meet both current and future requirements with a simple rotor / volute changes
- Ball-ball, sleeve-ball and sleeve-pivot shoe bearings are available

Applications

- Safety related services

Key characteristics

Capacities	up to 10'000 m ³ /h / 45'000 USgpm
Heads	up to 550 m / 1'800 ft.
Pressures	up to 150 bar / 2'200 psi
Temperatures	up to 200°C / 400°F



Single stage pumps

HZB double suction volute pump

Features and benefits

- Centerline mounting to allow free thermal expansion and high nozzle loads
- Minimum bearing span to minimize shaft deflection
- Single cover casing design to reduce overhaul times
- Chrome steel casing with good corrosion resistance and excellent mechanical properties is standard
- Single mechanical seal provides higher efficiency

Applications

- Feedwater booster
- Safety related services

Key characteristics

Capacities	up to 5'500 m ³ /h / 29'000 USgpm
Heads	up to 340 m / 1'115 ft.
Pressures	up to 48 bar / 700 psi
Temperatures	up to 220°C / 428°F



CD between bearings single stage pump ISO 13709 / API 610 BB2

Features and benefits

- Centerline support for reduced thermally induced misalignment
- Double suction impeller for low low Net Positive Suction Head Required (NPSHR)
- First critical speed is well above operating speed range for smooth operation
- Casing designed for 2 times API 610 nozzle loads for freedom from piping distortions
- Grouted or ungrouted, 1x or 2x nozzle load baseplates for reduced installation cost

Applications

- Feedwater
- Feedwater booster

Key characteristics

Capacities	up to 7'000 m ³ /h / 30'000 USgpm
Heads	up to 800 m / 2'600 ft.
Pressures	up to 100 bar / 1'450 psi
Temperatures	up to 425°C / 800°F



ZFn horizontal volute type process pump

Features and benefits

- Basic design according API 610 latest edition
- Casing designed for higher nozzle loads to comply with nuclear requirements
- Proven hydraulic design from our API 610 pump range ZE/ZF
- Enlarged shaft diameter compared to API 610 to match nuclear requirements
- Low rotor bending
- High dry running critical speed
- Designs according to RCC-M available

Applications

- Safety related services

Key characteristics

Capacities	up to 2'600 m ³ /h / 11'440 USgpm
Heads	up to 300 m / 1'000 ft.
Pressures	up to 100 bar / 1'450 psi
Temperatures	up to 425°C / 800°F



OHH overhung single stage pump ISO 13709 / API 610 OH2

Features and benefits

- Finned bearing housing and fan cooling for long bearing life
- Broadest range map in the industry for ISO 13709 (API 610) type OH2 pumps
- Heavy duty baseplates with 2x ISO 13709 (API 610) nozzle load option
- ISO 21049 (API 682) cartridge type mechanical seals for reduced emissions
- Electric motor, Variable Frequency Drive (VFD), engine and steam turbine drivers

Applications

- Auxiliary services

Key characteristics

Capacities	up to 2'250 m ³ /h / 10'000 USgpm
Heads	up to 360 m / 1'200 ft.
Pressures	up to 75 bar / 1'110 psi
Temperatures	up to 425°C / 800°F



REL horizontal diffuser style single stage pump

Features and benefits

- Casing designed for higher nozzle loads to comply with nuclear requirements
- Proven hydraulic design from our API 610 pump range ZE/ZF
- Enlarged shaft diameter compared to API 610 to match nuclear requirements
- Low rotor bending
- High dry running critical speed
- Designs according to RCC-M available

Applications

- Safety related services

Key characteristics

Capacities	up to 2'600 m ³ /h / 11'440 USgpm
Heads	up to 300 m / 1'000 ft.
Pressures	up to 100 bar / 1'450 psi
Temperatures	up to 425°C / 800°F

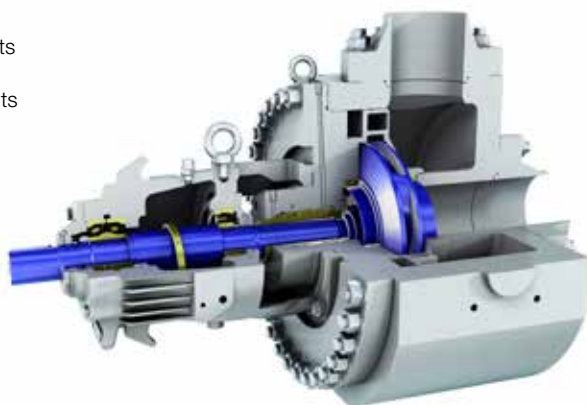

Vertical pumps

SJT and SJM vertical pumps

Features and benefits

- Optimized hydraulics for high efficiency
- Packed stuffing box for reliable sealing and simple maintenance; mechanical seal is optional
- Rubber-lined product-lubricated bearing in bowls and columns for long maintenance-free periods; other bearing materials are also available
- Optional spacer coupling allows servicing of the seal area and thrust bearing as required

Applications

- Cooling water pumps
- Safety related services
- Nuclear service water
- Auxiliary services

Key characteristics

Capacities	up to 62'000 m ³ /h / 270'000 USgpm
Heads	up to 110 m per stage / 350 ft. per stage
Pressures	up to 64 bar / 930 psi
Temperatures	up to 50°C / 122°F

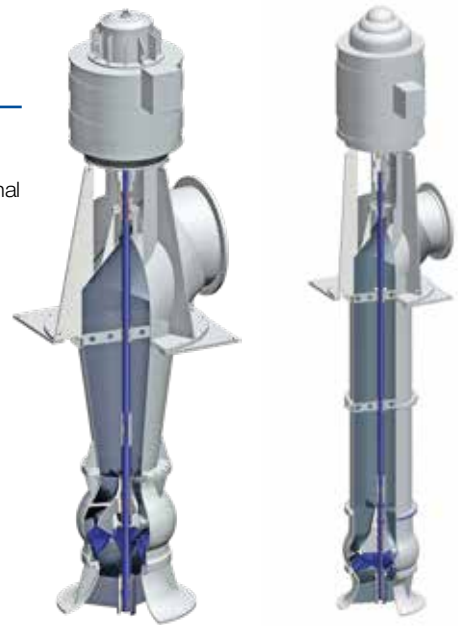

Vertical double casing can pumps

VCR high pressure vertical double casing can pump

Features and benefits

- Ease of maintenance
- Accessibility
- No inducer required
- High pump and motor efficiency
- Proven reliability

Applications

- Heater drain
- Condensate extraction
- Safety related services for NPP

Key characteristics

Capacities	up to 1'130 m ³ /h / 5'000 USgpm
Heads	up to 2'450 m / 8'000 ft.
Pressures	up to 100 bar / 1'440 psi
Temperatures	up to 200°C / 400°F



Product overview for turbine island

Feedwater booster pumps

HZB double suction volute pump

Features and benefits

- Centerline mounting to allow free thermal expansion and high nozzle loads
- Minimum bearing span to minimize shaft deflection
- Single cover casing design to reduce overhaul times
- Chrome steel casing with good corrosion resistance and excellent mechanical properties is standard
- Single mechanical seal provides higher efficiency

Applications

- Feedwater booster
- Safety related services

Key characteristics

Capacities	up to 5'500 m ³ /h / 29'000 USgpm
Heads	up to 340 m / 1'115 ft.
Pressures	up to 48 bar / 700 psi
Temperatures	up to 220°C / 428°F



Feedwater pumps

HPTd single stage double suction pump

Features and benefits

- Robust design to accept high piping loads
- Single cover design to reduce overhaul times
- Radial split design eliminates need for pre-warming
- Split bearing housings for bearing inspection without pump disassembly
- Single mechanical seal for higher efficiency

Applications

- Feedwater

Key characteristics

Capacities	up to 5'000 m ³ /h / 22'000 USgpm
Heads	up to 800 m / 2'625 ft.
Pressures	up to 150 bar / 2'175 psi
Temperatures	up to 220°C / 428°F

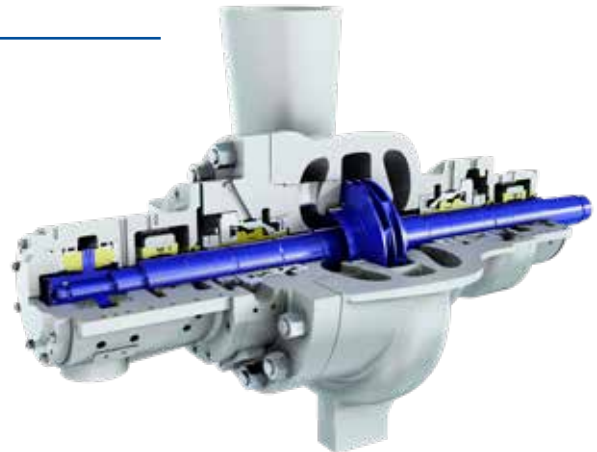

CD between bearings single stage pump ISO 13709 / API 610 BB2

Features and benefits

- Centerline support for reduced thermally induced misalignment
- Double suction impeller for low low Net Positive Suction Head Required (NPSHR)
- First critical speed is well above operating speed range for smooth operation
- Casing designed for 2 times API 610 nozzle loads for freedom from piping distortions
- Grouted or ungrouted, 1x or 2x nozzle load baseplates for reduced installation cost

Applications

- Feedwater
- Feedwater booster

Key characteristics

Capacities	up to 7'000 m ³ /h / 30'000 USgpm
Heads	up to 800 m / 2'600 ft.
Pressures	up to 100 bar / 1'450 psi
Temperatures	up to 425°C / 800°F



Condensate extraction pumps

SJD (CEP) vertical can mounted turbine type pump

Features and benefits

- Carbon graphite product lubricated bearing in bowls and columns for long maintenance-free periods
- Removable seal housing allows servicing throttle bushing without removing the head
- Separate fabricated driver stand allows using one suction and discharge head per pump size
- Spacer coupling allows servicing the mechanical seal and thrust bearing as needed
- Can is provided with lateral and anti-rotational ribs uniform inlet velocity along the can length

Applications

- Condensate extraction
- Heater drain

Key characteristics

Capacities	up to 4'900 m ³ /h / 21'560 USgpm
Heads	up to 470 m / 1'540 ft.
Pressures	up to 47 bar / 680 psi
Temperatures	up to 100°C / 212°F



Cooling water pumps

SJT/SJM CWP vertical pump

Features and benefits

- Modern fabricated suction bell and bowl casing incorporating swirl break for stable pump performance curve
- Semi-open or closed cast impeller design for best fitting and optimum efficiency
- Segmented elbow to reduce the internal losses
- Optional full pull-out construction to reduce lifting crane capacity and ease maintenance

Applications

- Condenser cooling water pumps

Key characteristics

Capacities	up to 90'000 m ³ /h / 396'000 USgpm
Heads	up to 60 m / 200 ft.
Pressures	up to 8.6 bar / 125 psi
Temperatures	up to 50°C / 122°F



SJT and SJM vertical pumps

Features and benefits

- Optimized hydraulics for high efficiency
- Packed stuffing box for reliable sealing and simple maintenance; mechanical seal is optional
- Rubber-lined product-lubricated bearing in bowls and columns for long maintenance-free periods; other bearing materials are also available
- Optional spacer coupling allows servicing of the seal area and thrust bearing as required

Applications

- Cooling water pumps
- Safety related services
- Nuclear service water
- Auxiliary services

Key characteristics

Capacities	up to 62'000 m ³ /h / 270'000 USgpm
Heads	up to 110 m per stage / 350 ft. per stage
Pressures	up to 64 bar / 930 psi
Temperatures	up to 50°C / 122°F

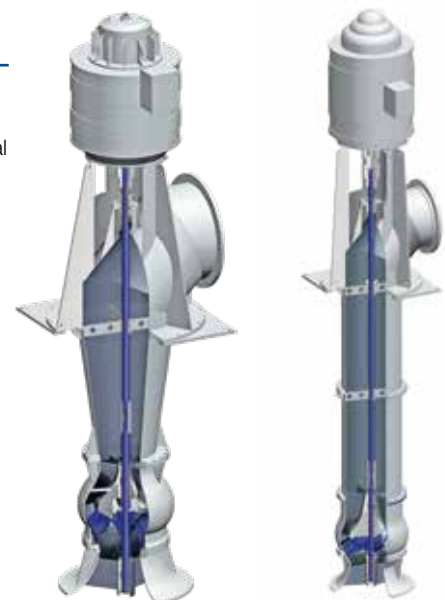

Auxiliary pumps

AHLSTAR end suction single stage long coupled centrifugal pump

Features and benefits

- Exceeds standard requirements of international ISO 5199 and ISO 2858 standards
- Suitable for the most demanding industrial applications
- Unique, patented and superior design features minimize life cycle costs
- Quick and easy installation, reliable operation, easy maintenance and service

Applications

- Auxiliary services

Key characteristics

Capacities	up to 11'000 m ³ /h / 48'400 USgpm
Heads	up to 160 m / 525 ft.
Pressures	up to 25 bar / 360 psi
Temperatures	up to 180°C / 355°F

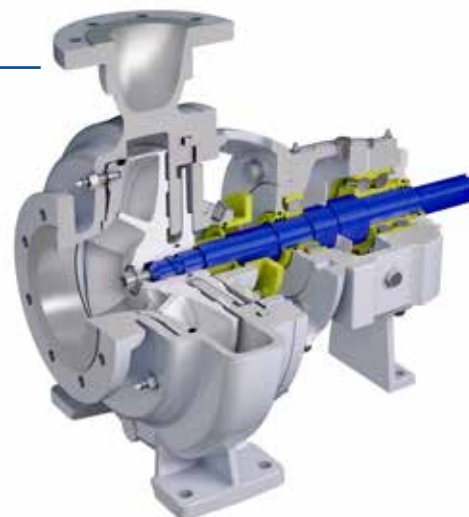

CPE end suction single stage centrifugal pump

Features and benefits

- Designed to exceed the strictest energy regulations for all the industries as well as the requirements of ASME B73.1
- Revolutionary hydraulics and high efficiency to offer the lowest life cycle costs
- Improved reliability
- Minimized total cost of ownership

Applications

- Auxiliary services

Key characteristics

Capacities	up to 1'650 m ³ /h / 7'000 USgpm
Heads	up to 275 m / 900 ft.
Pressures	up to 27.5 bar / 400 psi
Temperatures	up to 260°C / 500°F



OHH overhung single stage pump ISO 13709 / API 610 OH2

Features and benefits

- Finned bearing housing and fan cooling for long bearing life
- Broadest range map in the industry for ISO 13709 (API 610) type OH2 pumps
- Heavy duty baseplates with 2x ISO 13709 (API 610) nozzle load option
- ISO 21049 (API 682) cartridge type mechanical seals for reduced emissions
- Electric motor, Variable Frequency Drive (VFD), engine and steam turbine drivers

Applications

- Auxiliary services

Key characteristics

Capacities	up to 2'250 m ³ /h / 10'000 USgpm
Heads	up to 360 m / 1'200 ft
Pressures	up to 75 bar / 1'110 psi
Temperatures	up to 425°C / 800°F



SMD axially split casing double suction pump

Features and benefits

- Optimum hydraulic fit with high efficiency maintained over a wider flow range
- Exceptionally low Net Positive Suction Head Required (NPSHR) value not only at the best efficiency point but also on overload
- Maintenance-friendly features; excellent interchangeability of parts
- Horizontal and vertical constructions

Applications

- Auxiliary services

Key characteristics

Capacities	up to 25'000 m ³ /h / 110'000 USgpm
Heads	up to 260 m / 850 ft.
Pressures	up to 34 bar / 490 psi
Temperatures	up to 140°C / 280°F



SMN axially split casing double suction pump

Features and benefits

- Broad hydraulic coverage through over 50 different sizes
- High efficiency
- Robust design for long service life
- Easy maintenance
- Flexible layout enabled by clockwise and counterclockwise rotation as well as vertical and horizontal arrangements

Applications

- Auxiliary services

Key characteristics

Capacities	up to 10'000 m ³ /h / 44'000 USgpm
Heads	up to 200 m / 650 ft.
Pressures	up to 30 bar / 435 psi
Temperatures	up to 150°C / 302°F



CZ/ZA/ZE/ZF end suction pumps

Features and benefits

- Designed for hot or cold water medium design pressure applications with relatively low Net Positive Suction Head (NPSH) available
- Modular construction to provide maximum interchangeability of spares

Applications

- Auxiliary services

Key characteristics

Capacities	up to 2'600 m ³ /h / 11'440 USgpm
Heads	up to 300 m / 1'000 ft.
Pressures	up to 100 bar / 1'450 psi
Temperatures	up to 425°C / 800°F

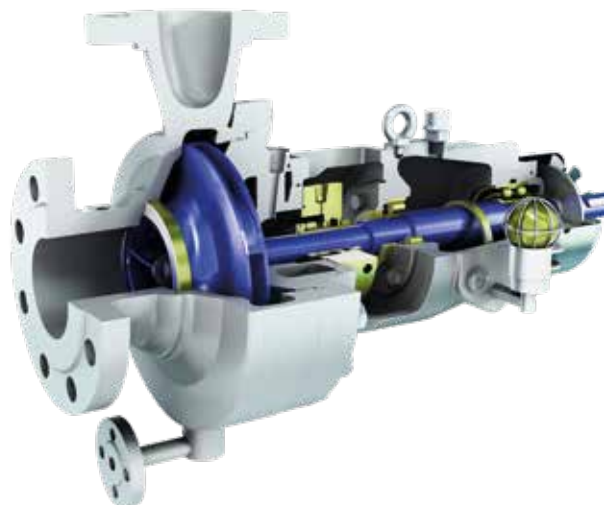

SJT and SJM vertical pumps

Features and benefits

- Optimized hydraulics for high efficiency
- Packed stuffing box for reliable sealing and simple maintenance; mechanical seal is optional
- Rubber-lined product-lubricated bearing in bowls and columns for long maintenance-free periods; other bearing materials are also available
- Optional spacer coupling allows servicing of the seal area and thrust bearing as required

Applications

- Cooling water pumps
- Safety related services
- Nuclear service water
- Auxiliary services

Key characteristics

Capacities	up to 62'000 m ³ /h / 270'000 USgpm
Heads	up to 110 m per stage / 350 ft. per stage
Pressures	up to 64 bar / 930 psi
Temperatures	up to 50°C / 122°F

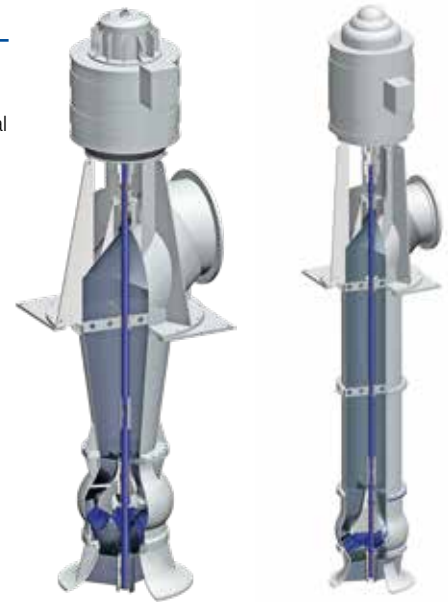

www.sulzer.com

E10006 en 8.2020, Copyright © Sulzer Ltd 2020
This brochure is a general presentation. It does not provide any warranty or guarantee of any kind. Please, contact us for a description of the warranties and guarantees offered with our products. Directions for use and safety will be given separately. All information herein is subject to change without notice.

