

SULZER

Nordic Water

Sedimentation solutions

SuperSettler

inclined plate separator



Main industries and applications

SuperSettler is a world-leading inclined plate settler, designed to maximize settling efficiency with minimal footprint. The unique flow control system represents a breakthrough in modern plate settler design and has contributed significantly to the excellent reliability and efficiency of the SuperSettler. The SuperSettler can reduce the footprint to as little as 10% of a traditional sedimentation tank. That makes it ideal for expanding capacity in existing plants or whenever space is scarce or costly.

We have more than 40 years experience of providing information for proper choice of equipment and delivering operating results.

SuperSettler provide excellent separation and clarification performance in a wide variety of water treatment applications, such as:

- Pre-water treatment
- Backwash water treatment
- Primary and secondary settling
- Tertiary treatment
- Sludge thickening
- Industrial process water
- Chemical industry – purification and thickening
- Pulp and paper industry
- Iron and steel industry, mill scale removal
- Metal finishing – treatment of metal surfaces
- Metal hydroxide wastewater
- Pressure/vacuum filtrate clarification
- Purification in biological cleaning processes
- Recirculation of water in the potato and vegetable industry
- Treatment of water in power plant dust scrubbers



Features and benefits

1 Plate design for enhanced separation

- Higher flow capacity on less footprint than conventional sedimentation
- Improved settling results on the same footprint
- Excellent hydraulic design ensures even flow distribution over the SuperSettler plates

2 Inlet openings for uninterrupted settling

- The liquid enters the plates through the sides in a unique and well proven flow control system to ensure that each individual plate receives the same flow rate
- Settled material falling off the plate is not disturbed

3 Well proven sustainable design

- Efficient separation of solids with basically no energy consumption involved
- None or a few moving parts gives reliable operation with long economic life span
- SuperSettler separators are designed to meet different site requirements and corrosive environments
- Various materials; stainless steel, painted mild steel or FRP

4 Automatic cleaning of SuperSettler plates with CleanBot

- Considerable savings in water and energy
- Improved water outlet quality due to regular cleaning
- Increased personnel safety



A wide range for maximum flexibility

The SuperSettler is available as free-standing models or plate packs, in different sizes and plate distances. All models can be customized for various needs. The free-standing models can optionally be equipped with one or more flocculation tanks with agitator and rapid mixer to improve flocculation and sedimentation. The SuperSettler is easy to install and with the few moving parts the operating and maintenance costs are very low.

LT – SuperSettler separator

The LS model consists of an independent SuperSettler separator with conical sludge hopper. The sludge is being removed by water pressure when a valve is opened. A rotating sludge scraper in the hopper is available as an option.

LT – SuperSettler thickener

The SuperSettler thickener is a tank model combined with a SuperSettler separator and a sludge thickening device with rotating sludge scraper. These units are designed for flows and applications with high solids content and thickened underflow and therefore has a cylindrical shape sludge compartment.

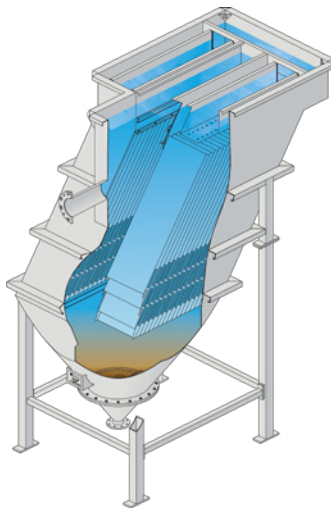

Lamella LS standard version

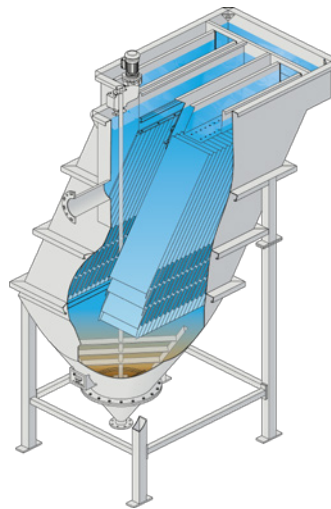

Lamella LS with sludge scraper

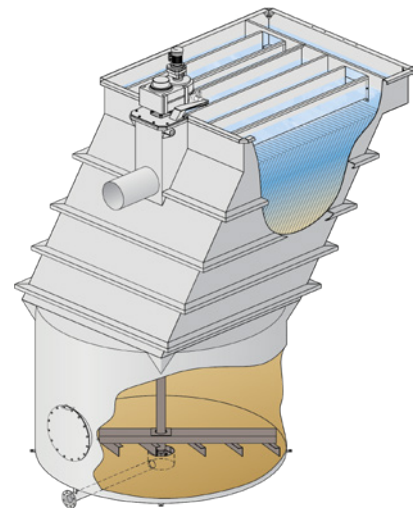

Lamella LT plate thickener with sludge thickening bottom tank

Flocculation tank

Both models LS and LT, can be equipped with a flocculation tank with an agitator. The tank can be equipped with a rapid flash mixer for efficient mixing of the flocculation agents.

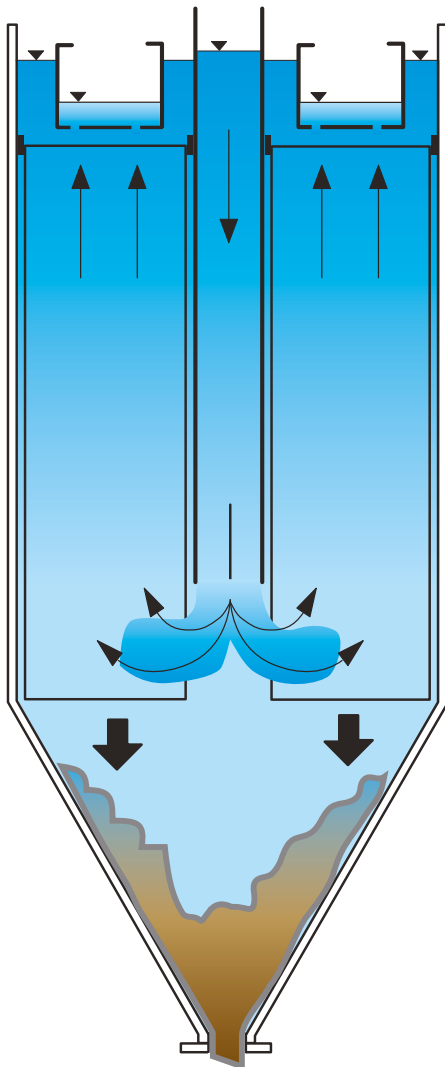

How the SuperSettler works

The feed enters through the feed pipe. As the liquid flows upward between the plates, the solids settle on the inclined plates and slide into the sludge hopper at the bottom of the unit. In the hopper, the sludge is thickened prior to discharge. The clarified liquid leaves the plate through openings at the top and is discharged into collection channels leading to the water outlet.

The even distribution of the flow to each plate ensures optimal operation at a high capacity. The side entry of the fluid prevents the solids that have settled from being carried away with the entering fluid.

Installation in tanks and basins

Plate packs

The models LP and LPS plate packs are made for installation in steel tanks or concrete basins. They are mainly used in large municipal facilities, but also work well in smaller plants and industries. The LP and LPS models offer significant cost savings and are particularly well suited for retrofitting to increase the capacity in existing basins. The plate packs are ideally combined with a Zickert Shark bottom sludge scraper.

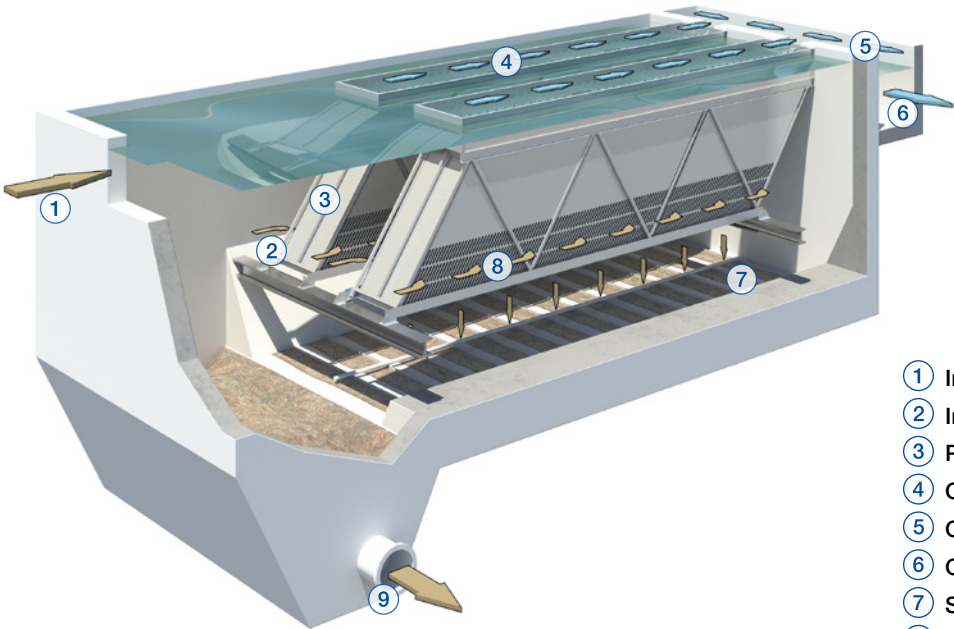

- ① Inlet
- ② Inlet section
- ③ Plate assembly
- ④ Collection flumes
- ⑤ Outlet flume
- ⑥ Clean water discharge
- ⑦ Sludge scraper
- ⑧ Plate assembly inlet openings
- ⑨ Sludge discharge

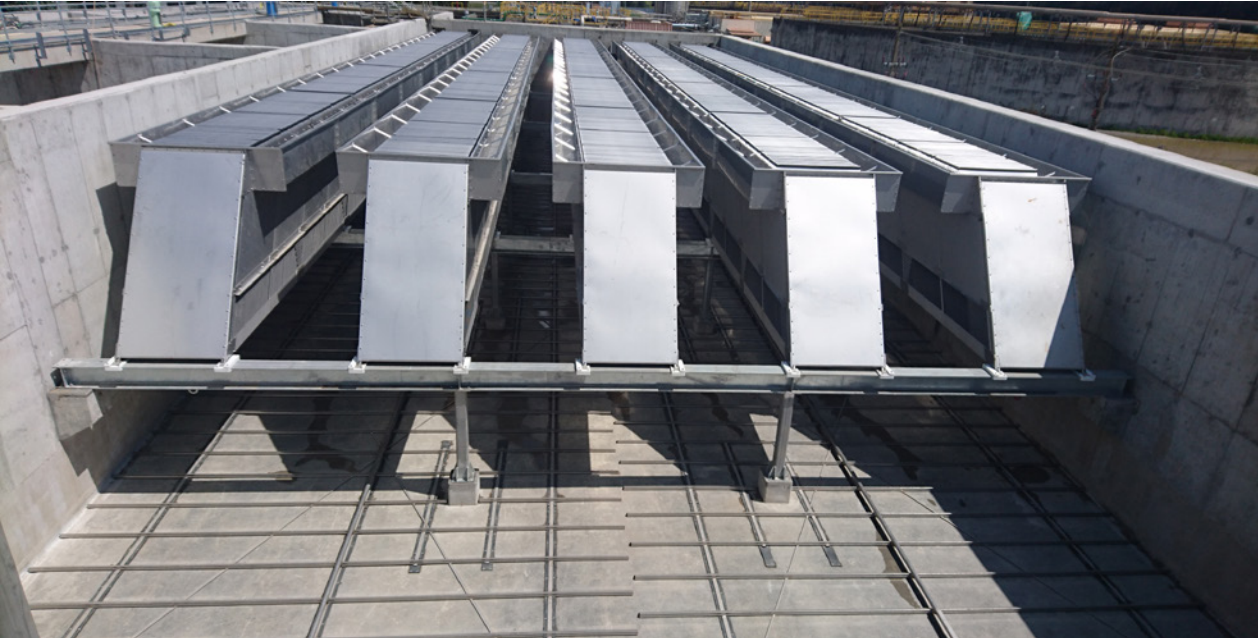

Zickert Shark bottom sludge scraper

The Zickert Shark sludge scraper is ideal for installation underneath SuperSettler packs due to its very low profile. It is specially designed for continuous sludge thickening and removal without disturbing the sludge blanket or interrupting the sedimentation process.

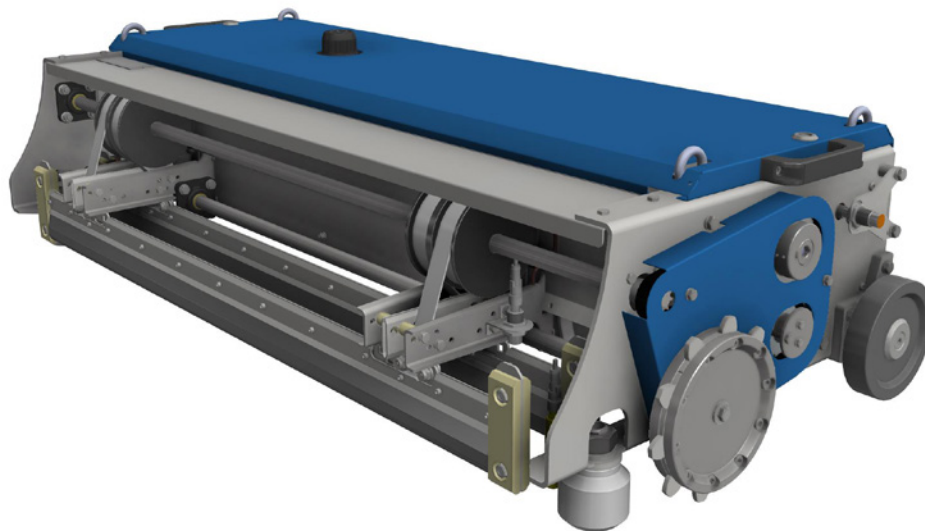

SuperSettler CleanBot

We recommend regular cleaning of the SuperSettler plates to avoid sludge accumulation. Using the automatic operated SuperSettler CleanBot, cleaning is performed without personnel during normal operation. There is no need to take the SuperSettler out of operation or to lower the water level for cleaning.

For any inquiries please contact us:

Sulzer North America Industrial
Wastewater Treatment Sales
2850 Red Hill Avenue, Ste. 125
Santa Ana, CA 92705
800.331.2277
714.833.3888

The Sulzer Flow division keeps your processes flowing. Wherever fluids are treated, pumped, or mixed, we deliver highly innovative and reliable solutions for the most demanding applications.

The Flow division specializes in pumping solutions specifically engineered for the processes of our customers. We provide pumps, agitators, compressors, grinders, screens and filters developed through intensive research and development in fluid dynamics and advanced materials. We are a market leader in pumping solutions for water, oil and gas, power, chemicals and most industrial segments.

E10800 us 1.2025, Copyright © Sulzer Ltd 2025

This brochure is a general presentation. It does not provide any warranty or guarantee of any kind. Please, contact us for a description of the warranties and guarantees offered with our products. Directions for use and safety will be given separately. All information herein is subject to change without notice.

