

---

**Light Drainage Pump Type ABS Coronada 250**

---

1131-00

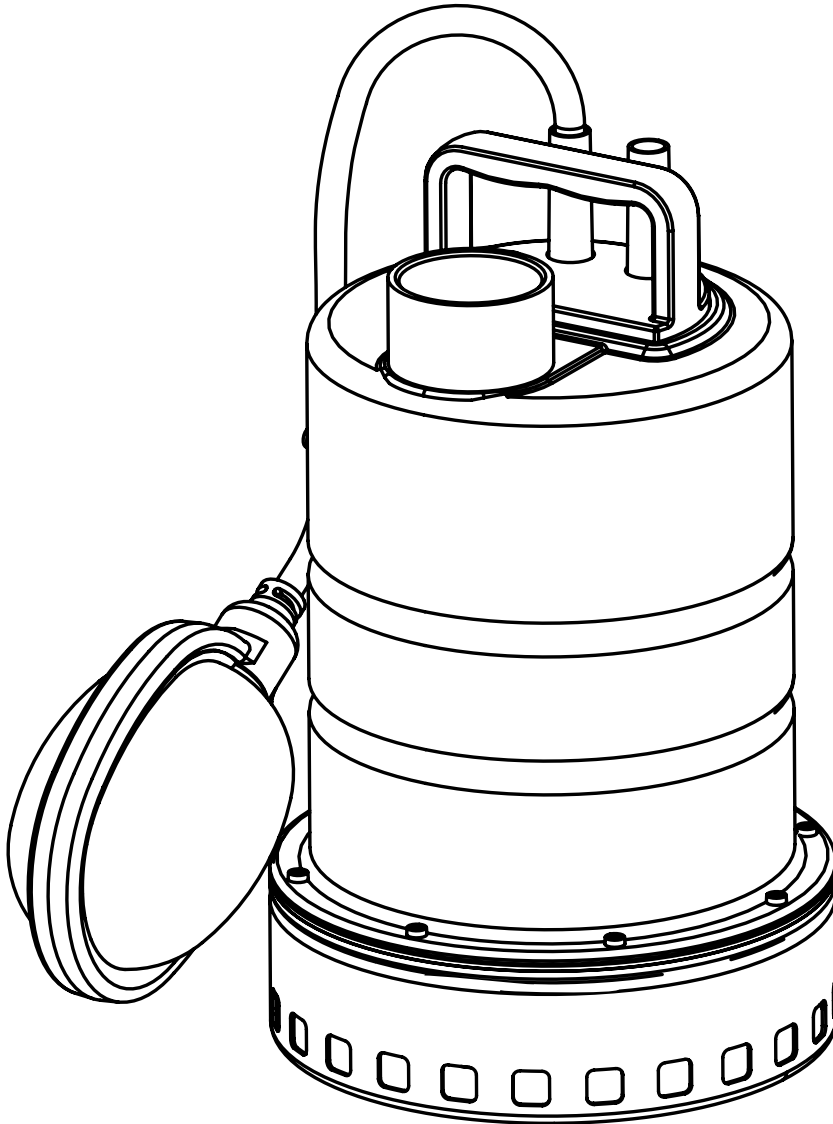

15970287EN (05/2016)

**EN**

---

**Installation and Operating Instructions**

---

## Light Drainage Pump Type ABS Coronada 250

This manual is available to download from [www.sulzer.com](http://www.sulzer.com) > Products & Services > Pumps and Systems.

### Symbols and notices used in this booklet:



Non-compliance may result in personal injury.



Presence of dangerous voltage.

**NOTE:** *Important information for particular attention.*

Symbols directly on the unit itself must be carefully observed and must be maintained in a legible condition, e.g. direction of rotation arrow and nameplate.

### Safety

(Extracted from VDMA-Standard sheet 24292)\*

This unit can be used by children aged 8 years and above, and persons with reduced physical, sensory, or mental capabilities, or lack of experience and knowledge, when they have been given supervision or instruction concerning the safe use of the device and understand the hazards involved. Children must not play with the appliance. Cleaning and user maintenance should not be performed by children without supervision.



To avoid injury, when the pump is in operation, do not handle the impeller screen.

These operating instructions contain basic information on erection, operating and maintenance and should be followed carefully. For this reason it is essential that these instructions are carefully read before erection or commissioning by both the installation crew as well as those responsible for operation or maintenance. The operating instructions should always be readily available at the location of the unit.

In addition to following the safety regulations of a general nature listed under these main headings, it is also essential that the special safety instructions given under other headings be observed.

The safety instruction listed in this operating manual, the existing National Regulations for safety, as well as any internal operating or safety regulations which apply in the user's own premises must be observed.

The general and specific health and safety guidelines are described in detail in the "Safety Instructions for Sulzer Products Type ABS" booklet. If anything is not clear or you have any questions as to safety make certain to contact the manufacturer Sulzer.

### Dangers which could arise due to non-observance of safety instructions

The non-observance of the safety instructions can lead to both danger to personnel and also to possible harm to the environment or the unit itself. Non-observance of the safety instructions can invalidate the rights of the user to any compensation or redress.

In detail, non-observance can for example result in the following dangers:

- Failure of important functions of the unit/installation
- Danger to personnel by electrical, mechanical or chemical influences
- Danger to the environment by leakage of dangerous substances

**NOTE:** *Carry out work in a safety conscious manner.*

### Safety regulations for the owner/operator

All dangers due to electricity must be avoided (for details consult the Regulations of your local Electricity Supply Company).

### Safety regulations for maintenance, inspection and installation work

The user of the unit should ensure that all maintenance, inspection or installation work is carried out by authorised and qualified skilled personnel. The user must also make certain that they have carefully studied the operating instructions. In principle all work on the unit should only be carried out while it is stationary. Pumps or units, used for pumping of fluids which could be injurious to health must be decontaminated. After completion of the work all safety and protective devices must be refitted and a check should be made that they are fully functional. Before starting up again, the points listed under the section "Commissioning" should be complied with.

### Unilateral modification and spare parts manufacturing

Modifications or changes to the unit/installation should only be carried out after consultations with the manufacturer. Original spare parts and accessories authorised by the manufacturer are essential for compliance with safety requirements. The use of other parts can invalidate any claims for warranty or compensation.

### Unproven usage

The operating safety of the unit is only guaranteed provided that the unit is used in accordance with the operating and safety instructions. The limit values given in the technical data sheet should under no circumstance be exceeded.

These installation and operation instructions do not supersede or exclude the following of generally valid regulation and standards.

\*VDMA=Verband Deutscher Maschinen- und Anlagebau e.V. (German Machinery Manufacturers Association).



End of life units can be returned to Sulzer or recycled in accordance with local regulations.

## Transport

During transport the unit should not be dropped or thrown.



**The unit should never be raised or lowered by the power cable.**

A handle is provided for transport. If necessary, it is possible to suspend the pump by attaching a rope or chain to the handle.

## Application

The submersible wastewater pumps of the Coronada series are reliable quality products designed for the following applications:

- Pumping of clear water.
- Pumping of rain water.
- Pumping of wastewater containing solids up to 10 mm.
- SX-version for industrial wastewater with aggressive content.



**The pump must not be used in an explosive or flammable environment or for pumping flammable liquids.**

**NOTE:** *As with all electrical devices, this product may fail due to operating errors, absence of mains voltage, or even a technical defect. Such a failure may result in the medium or water escaping. If damage may occur due to such failures, measures are required to avoid damage arising. In this respect, taking account of the conditions in question, use of an emergency generator, provision of an additional and appropriately connected second unit, and particularly the use of an off-grid alarm system, are to be considered.*

These pumps should not be used for the pumping of: faecal matter.

Before using the standard or SX-Versions the chemical resistance of the materials should be checked.

The pumps conform to the EU machine directive. See nameplate.

**NOTE** *Leakage of lubricants could result in pollution of the medium being pumped.*

## Nameplate

We recommend that you record the data from the standard nameplate on the pump in the corresponding form below, and maintain it as a source of reference for the ordering of spare parts, repeat orders and general queries.

Always state the pump type, item no. and serial no. in all communications.

<b>SULZER</b>		CE	xx/xxxx	IP68		
Typ						
Nr	SN					
U	V	Ph	A	Hz	P1	kW
Qmax	m <sup>3</sup> /h		Hmax	1/min		
				▽	m	
Sulzer Pump Solutions Ireland Ltd. Wexford, Ireland www.sulzer.com Made in Ireland						

1190-03

## Legend

Typ	Pump type	
Nr.	Item number	
SN	Serial number	
xx/xxxx	Production date (Week/Year)	
U	Rated Voltage	V
Ph	Number of phases	
	Rated Current	A
	Frequency	Hz
P1	Rated Input Power	kW
Qmax	Max. Flow	m <sup>3</sup> /h
Hmax	Max. Head	m
1/min	Speed	r/min
IP	Protection type	
▽	Max submersible depth	m

## Performance

Maximum total head: 7 m

## Commissioning

The manufacturer guarantees that a new pump will not emit airborne noise in excess of 70 dB(A) during normal operation, when either fully or partially submerged.

Before commencing operations, the pump/pump station should be examined and a function check carried out. Particular attention should be paid to the following:

- Check that the power cable and plug are undamaged.
- Does the electrical connection comply with regulations?
- Is the motor overload correctly set?
- Is the level control system operating correctly?
- Are the switch ON switch OFF levels correctly set?



**The pump must not be run if it has been partially dismantled.**



**To avoid personal injury, or damage to the pump, disconnect it from the power supply before removing or fitting the suction ring.**



**In all installations, the power supply to the Coronada pump must be via a residual current device (e.g. RCD, ELCB, RCBO etc.) with a rated residual operating current not exceeding 30 mA. For installations not having a fixed residual current device the pump must be plugged into the power supply through a portable version of the device.**



In the case of Class I (EN 60335) submersible pumps such as the Coronada series, all accessible metal parts are connected to the earth lead. Before operation a qualified person should check that the earth lead is correctly connected.



Coronada pumps must not be operated in places where a person could be immersed or in contact with the pumped medium, either intentionally or accidentally, e.g. swimming pool, garden pond, fountain, flooded area.



Pumps for use in swimming pools where people are present must only use Class III (EN 60335) pumps with a voltage not greater than 12 V.

**NOTE**

*Suitable earth leakage protection devices are available from electrical suppliers. Please consult your electrician.*

**Electrical connections**

The pump must be connected to terminals or starting equipment installed at a level at which the pump cannot be flooded.



**All electrical equipment must always be earthed (grounded). This applies to the pump and to any monitoring equipment.**



**The electrical installation must conform to national and local regulations.**

Check that the mains voltage, frequency, starting equipment, and method of starting agree with the particulars stamped on the motor nameplate.

The unit should be protected by a correctly dimensioned slow blow fuse (suitable for the rated power of the pump). We recommend the use of an overload relay. The electrical installation shall be inspected by an authorized electrician.

**Service and maintenance**

**Before any work is started, check that the pump is isolated from the power supply and cannot be energized.**



**To avoid danger if the power cable is damaged, it must be replaced by the manufacturer or its service agent or a similarly qualified person.**

Regular inspection and preventive maintenance will ensure more reliable operation. The pump should be inspected every six months, but more frequently if the operating conditions are difficult. However, should a fault occur, do not attempt to improvise but call on your Sulzer Service Centre. This applies particularly in the case where the unit is continually switched off by the current overload in the control panel, or by the thermal sensors of the thermo-control-system.

For a complete overhaul of the pump, please get in touch with an authorized Sulzer workshop or your Sulzer dealer.

If the pump is taken out of service, in order to prevent deposition of soil or other materials the pump should be cleaned by pumping clear water.

If there are leaves or fibrous matter in the medium being pumped we recommend that the inlet screen be cleaned from time to time.

**To clean the screen proceed as follows:**

- Completely disconnect the pump from the power mains.
- Place the pump in a horizontal position.
- Remove the screen.
- Clean the inside of the screen, removing any particles that may have been sucked in.
- Ensure that all screen slots are free from foreign bodies.
- Reassemble the screen.

**KS-version:**

- Clean float

**Coronada 250 assembly**