

Submersible drainage pump XJ 110

SULZER

Specification

Electric submersible pump.

Maximum submergence: 65 ft. Protection class IP 68.

Max temperature of pumped medium at max power input and continuous duty 104 °F.

Max medium density 0.0397 lbs/inch³. pH of the pumped medium 5-8.

Strainer hole: 5/16" x 7/8". Max number of starts 30/hour.

XJ 110 ND Medium head, 3-phase

XJ 110 ND AT* Medium head, 3-phase

XJ 110 HD High head, 3-phase

XJ 110 HD AT* High head, 3-phase

*AquaTronic: Built-in electronic pump control.

Electric motor

3-phase squirrel-cage induction motor, 60 Hz.

Service factor 1.1. Class F insulation.

Dual voltage stator 230/460 V (single voltage contactor coil).***

Motor rating P₂: 18 Hp. 2 pol. Speed: 3500 rpm.

η: 90 (50 %), 91 (75 %), 90.8 (100 % load).

***For pumps with built in contactor.

Voltage, V	230	460	575
Nominal current, A	42.8	21.4	17.1

Starting method and motor protection

XJ 110 AT: Direct on line start (DOL 575 V) with built in AquaTronic unit, which automatically adjusts phase order by dual contactors, ensuring correct motor rotation.

Soft start (460 V) is built in with the AquaTronic unit, where three thyristors reduces start current to three times the nominal current.

Here two relays ensure correct motor rotation.

The AquaTronic unit monitors motor temperature, by use of NTC thermistors built into stator windings, and stops the motor at high temperature. It will also stop the motor at high amperage or if a phase is missing.

XJ 110: Direct on line start with built in contactor. Pumps to be used with VFD must have terminal block instead of contactor.

Thermal switches (284 °F, ±5) built into the stator windings are connected to the contactor and stop the pump at high temperature.

Power cable

Heavy duty power cable for submersible pump applications.

65 ft AWG 8/4 W (UL, CSA, MSHA) 208, 230 and 460 V

65 ft AWG 10/4 SOOW (UL, CSA, MSHA) 575 V

Shaft seal

Double mechanical seal in oil bath.

Primary seal: Silicon carbide on silicon carbide.

Secondary seal: Silicon carbide on carbon.

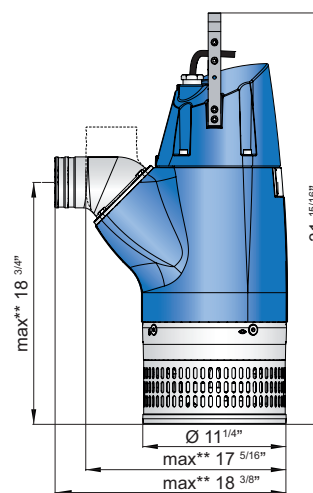
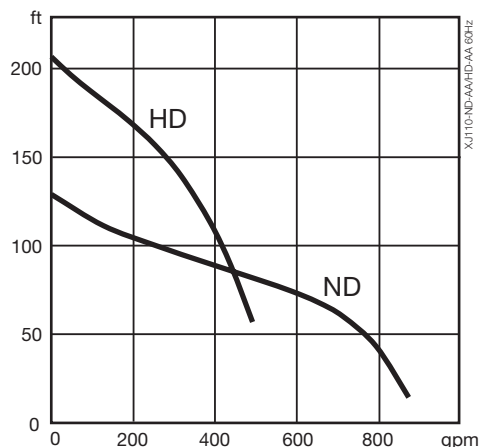

** Max measurement based on largest discharge size.

Bearings

Upper bearing: Single-row deep groove ball bearing.

Lower bearing: Double angular contact ball bearing.

Discharge connections

3", 4", 6" hose connections.

3" (standard HD), 4" (standard ND), 6" NPT threaded connections.

Weight

179 lbs (without cable)

Options and accessories

AquaTronic control panel. Level sensor. Service data kit. Zinc anodes.

Surface protection coating. Series connection. Floatation system.

Discharge connection accessories and hose.

Pump control

Features	XJ 110	XJ 110 AT				Service Data Kit Read out
		AT	AT + Level Sensor	AT + AquaTronic Control Panel	AT + AquaTronic Control Panel + Level Sensor	
Run mode	X	X	X	X	X	
Integrated start equipment	X	X	X	X	X	
Automatic direction of rotation		X	X	X	X	
Motor protection high temp	X	X	X	X	X	X
Motor protection high amp		X	X	X	X	X
Protection against missing phase		X	X	X	X	X
Level control			X		X	
Dry run protection			X		X	
Automatic restarting			X		X	
Stop mode				X	X	
E-mode (Automatic stop/run)			X		X	
Indication of water in oil				X	X	X
Indication of low motor insulation				X	X	X
Indication of high or low voltage				XX	XX	X
Indication of high temperature				XX	XX	X
Indication of high amp				XX	XX	X
Indication of phase unbalance				XX	XX	X
USB cable connection		X	X	X	X	X
Crash log (10 latest)						X
Documentation (spare part list, workshop manual)						X

XX = Fault indication when pump is automatically stopped to protect the motor.

Materials

Description	Material	EN	ASTM
Castings	Aluminium	EN 1706:AC-43100	ASTM AISi10mg
Strainer/Handle	Stainless steel	10088:X5CrNi18-10 (1.4301)	AISI 304
Rotor shaft	Stainless steel	10088:X20Cr13 (1.4021)	AISI 420
Impeller / Wear ring	High-chrome alloy	EN-GJN-HV600(XCr23)	ASTM A 532: Alloy III A
Fasteners	Stainless steel	10088:X5CrNiMo 17122 (1.4401)	AISI 316
Wear parts / O-rings	Nitrile rubber		
Coating	2 component epoxy paint 120 µm		