

No: M-14.0445 - 01

Dat/Nam.: 10.05.2016 / K. Radke

Cad Code: M\_140445

Technical changes reserved  
Änderungen vorbehalten  
Sous réserve de modifications

# XRCP800 (PE)

Dimension sheet XRCP800

Maßblatt XRCP800

Plan d'encombrent XRCP800



Type Typ Type	Type Typ Type	Weight Gewicht Poids	
		(~kg)	(~lb)
50Hz	60Hz		
PE 300/4	PE 350/4-60	675	1488

Weight: Includes pump, slider bracket and 10m cable  
Gewicht: Beinhaltet Pumpe, Halterung und 10m Kabel  
Poids: Pompe, coulisseau et 10m de câble

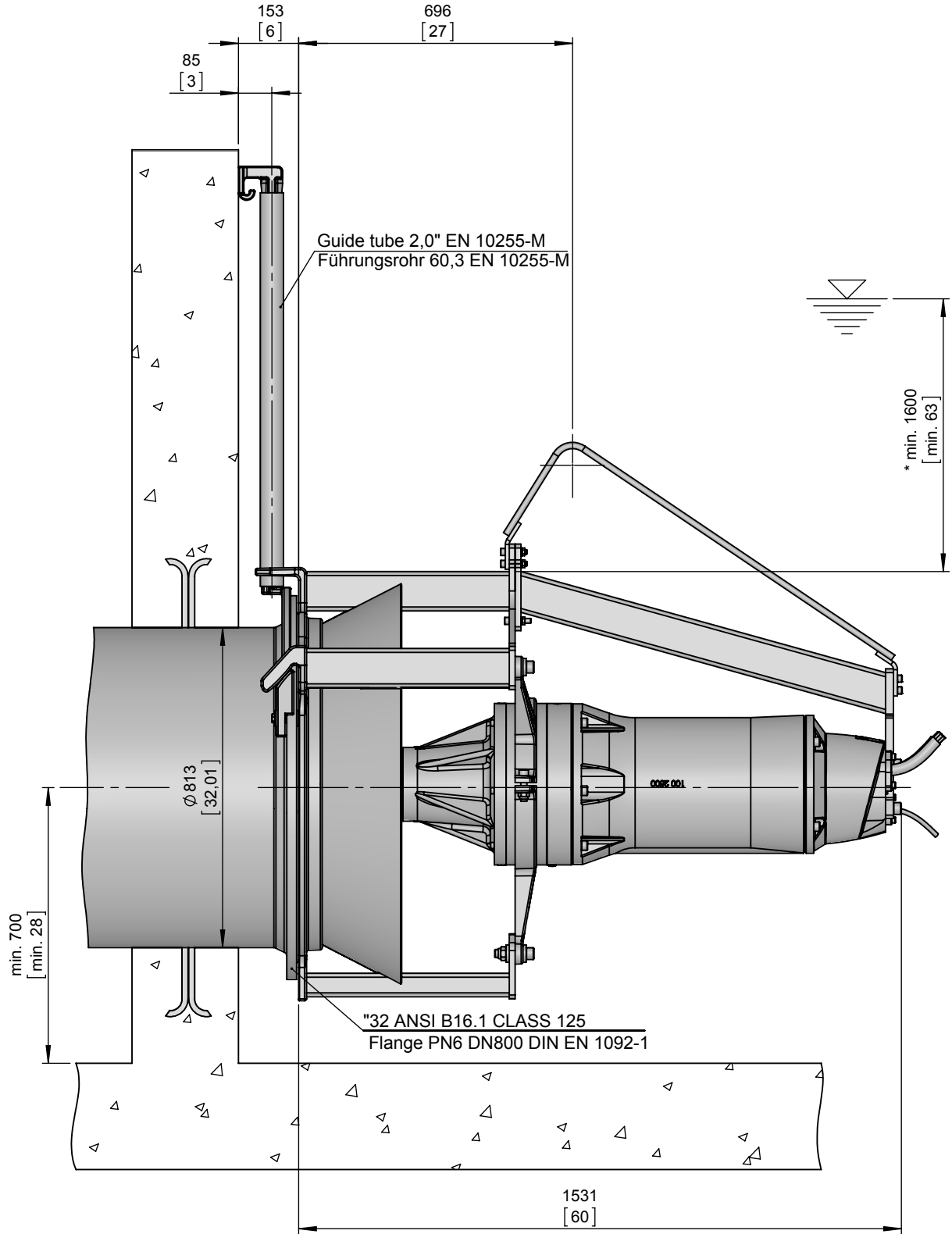

\*Guideline value: Minimum submergence can be lower

Richtwert: Die Mindestüberdeckung kann geringer sein

Valeur indiquée: la submergence minimale peut s'avérer inférieure en pratique

[ mm ]  
[ inch ]

No: M-14.0444 - 00  
 Dat/Nam.: 08.01.2015 / L.Henrich  
 Cad Code: M\_140445

Technical changes reserved  
 Änderungen vorbehalten  
 Sous réserve de modifications

# XRCP800 (PE)

Dimension sheet XRCP800

Maßblatt XRCP800

Plan d'encombrement XRCP800



Type Typ Type	Type Typ Type	Weight Gewicht Poids	
50Hz	60Hz	(~kg)	(~lb)
PE300/4	PE350/4-60	675	1488

Weight: Includes pump, slider bracket and 10m cable  
 Gewicht: Beinhaltet Pumpe, Halterung und 10m Kabel  
 Poids: Pompe, coulisseau et 10m de câble

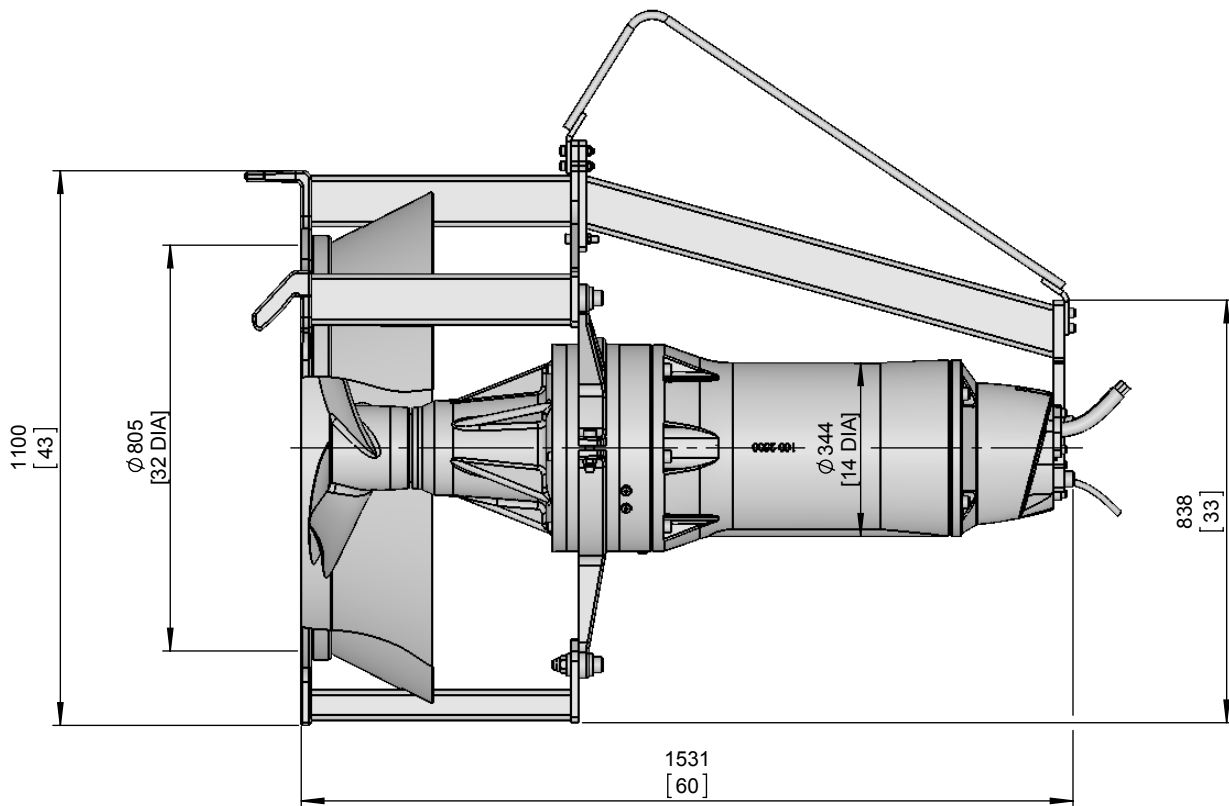

[ mm ]  
 [ inch ]