

Submersible Trash Pump JS 15

SULZER

Specification

Electric submersible pump.

Maximum submergence: 65 ft. Protection class IP 68.

Max temperature of pumped medium at max power input and continuous duty 104 °F.

Max medium density 0.0397 lbs/inch³. pH of the pumped medium 5-8.

Free passage Ø 1 9/16". Max no. of starts 30/hour.

Max impeller diameter requires half motor or more submersed for continuous duty. (Pump can operate lying down.)

JS 15 D/DKS* -104** 3-phase

JS 15 D/DKS* -114 3-phase

* option: built in float switch excl. 575 V

** Impeller diameter for duty with low water level or intermittent duty dry running.

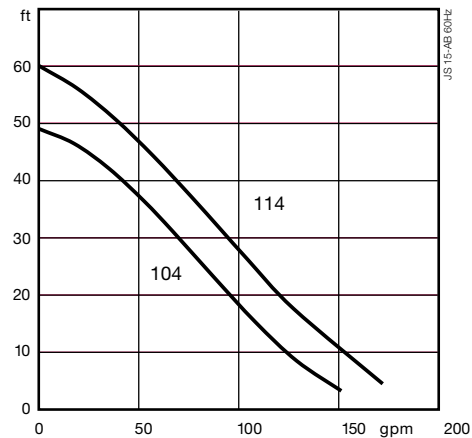

Electric Motor

3-phase squirrel-cage induction motor, 60 Hz.

Service factor 1.1. Class F insulation.

Dual voltage stator 230/460 V (single voltage contactor coil).

Motor rating P₂: 2.3 Hp. Speed: 3320 rpm.

η: 83,8 (50 %), 81.0 (75 %), 76.1 (100 % load)

Voltage, V	208	230/460	575
Nominal current, A	6.9	6.2/3.1	2.5

Power Cable

Heavy duty power cable for submersible pump applications.

65 ft AWG 16/4 SOOW (UL, CSA, MSHA)

Motor Protection

Built-in thermal switches in the stator windings (284°F, ±5).

Shaft Seal

Double mechanical seal in oil bath.

Primary seal: Silicon carbide on silicon carbide.

Secondary seal: Silicon carbide on silicon carbide.

Bearings

Upper bearing: Single-row deep groove ball bearing.

Lower bearing: Single-row deep groove ball bearing.

Discharge Connections

2", 2 1/2", 3" hose connections.

2", 3" (standard) NPT threaded connections.

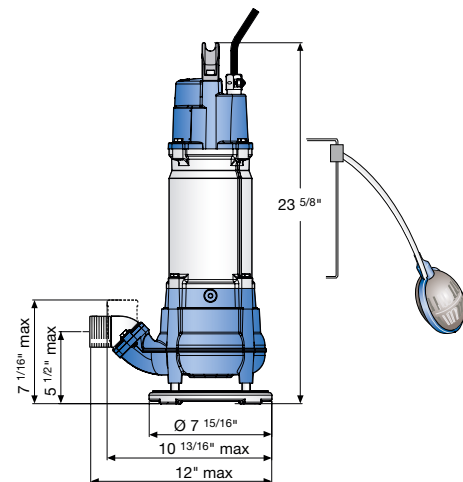

Weight

44 lb (without cable)

Options and Accessories

Zinc anodes. Surface protection coating.

Starter and control units.

Floatation ring. Repair kit.

Discharge connection accessories and hose.

Materials

Description	Material	ASTM
Motor housing	Aluminium	ASTM A510mg
Fasteners	Stainless steel	AISI 304
Rotor shaft	Stainless steel	AISI 420
Volute / Impeller	Nodular cast iron	ASTM A536-80:60-40-18
O-rings	Nitrile rubber	