

Lifting Station Type ABS Synconta 901B and 902B

SULZER

Synthetic prefabricated sump, designed as a single or double pumping station for the automatic pumping of wastewater and sewage from locations and areas below the backwash level in accordance with EN 12050-1. Designed as a complete wastewater sump for below-ground installation and for fitting with pumps from the Piranha, AS and MF ranges.

Features

- A concrete cover is available for areas where there can be either pedestrian or vehicular traffic (available as an accessory). The tank can be fitted with a plastic lockable lid where installations are removed from all forms of traffic e.g. garden flower beds.
- Stainless steel discharge pipe with 1¼" (901B), or 1½" (902B) external thread.
- Synconta 901B uses one pump, 902B uses two.
- Standard depth is 1690 mm, extending to a maximum of 2500 mm when fitted with an extension piece (available as an accessory).
- Four inflow ports (3 x DN 150, 1 x DN 200) for DIN push-on connection. Two DN 100 ports for venting and use as a cable duct.
- Simple pump installation and maintenance, it is not necessary to enter the sump. The pump seals automatically onto the discharge line when lowered into the high level coupling.
- The pipework and gate valves are made of high quality stainless steel.
- Level control is by one of three options; pressure pipe, float switch or float sensor.
- Maximum allowable temperature of medium 40 °C, short term to 60 °C (max. 5 minutes).



Materials

	Description	Material
	Tank	Polyethylene
AS pump	Motor housing	Cast iron EN-GJL-250
	Rotor shaft	Stainless steel 1.4021 (AISI 420)
	Volute	Cast iron EN-GJL-250
	Impeller	Cast iron EN-GJL-250
	Bottom plate	Cast iron EN-GJL-250
	Fasteners	Stainless steel 1.4401 (AISI 316)
Piranha pump	Upper lid *	Stainless steel 1.4301 (AISI 304)
	Motor housing	Cast iron EN-GJL-250
	Rotor shaft	Stainless steel 1.4021 (AISI 420)
	Volute	Cast iron EN-GJL-250
	Impeller	Cast iron EN-GJL-250
MF pump	Fasteners	Stainless steel 1.4401 (AISI 316)
	Upper lid	Stainless steel 1.4301 (AISI 304)
	Motor housing	Cast iron EN-GJL-250
	Rotor shaft	Stainless steel 1.4021 (AISI 420)
	Volute	Cast iron EN-GJL-250
	Impeller	Polyamide
	Fasteners	Stainless steel 1.4401 (AISI 316)

* Piranha 09 only.

Tank

Synthetic, corrosion-resistant tank in accordance with EN 12050-1. Supplied as standard with high-level coupling and bracket, ball type non-return valve and shut-off valve.

Tank cover, level control and pump(s) not included.

Capacity (L): 977

Weight (kg)*: 82 (Synconta 901B)
92 (Synconta 902B)

* Includes installation pipework but not weight of pump (see technical data table).

Motor

Water pressure sealed, squirrel cage 2-pole induction motors with triple shaft seals and oil chamber.

Electronic monitoring of stator temperature.

Insulation: Class F to 155 °C

Protection type: IP 68

Pumps

- Submersible wastewater pump type ABS MF / AS with vortex hydraulics for pumping clear water and wastewater with large solid particles present. Up to 40 mm solids passage.
- Submersible grinder pump type ABS Piranha. Shredding system hydraulics which can cut and pump wastewater containing solids through small diameter discharge lines from 1¼".

Technical data

Pump type	Piranha 09 W/KS	Piranha 09 D/KS	Piranha S12/2 W	Piranha S12/2 D	Piranha S17/2 W	Piranha S17/2 D	Piranha S21/2 D	Piranha S26/2 D
Pump discharge internal thread	G 1 ¼"	G 1 ¼"	G 1 ¼"	G 1 ¼"	G 1 ¼"	G 1 ¼"	G 1 ¼"	G 1 ¼"
Hydraulics	Macerator	Macerator	Macerator	Macerator	Macerator	Macerator	Macerator	Macerator
Motor power * (kW): P ₁	2.56	2.56	1.77	1.69	2.36	2.31	2.79	3.43
P ₂	1.84	2.0	1.20	1.20	1.65	1.70	2.10	2.60
Rated current (A)	11.6	4.64	8.22	3.29	10.60	3.97	4.75	5.64
Rated voltage (V)	220-240 1~	400 3~	220-240 1~	400 3~	220-240 1~	400 3~	400 3~	400 3~
Speed (r/min)	2900	2900	2900	2900	2900	2900	2900	2900
Cable ** (HO7RN-F)	3G 1.0	4G 1.0	4G 1.5	4G 1.5	4G 1.5	4G 1.5	4G 1.5	4G 1.5
Pump weight (kg)	23	23	32	32	32	32	37	40

Pump type	AS 0530 S12/2 W	AS 0530 S12/2 D	AS 0530 S17/2 D	AS 0530 S26/2 D	MF 354 W	MF 404 D	MF 504 W	MF 804 D
Pump discharge internal thread	G 2"	G 2"	G 2"	G 2"	G 2"	G 2"	G 2"	G 2"
Hydraulics	Vortex	Vortex	Vortex	Vortex	Vortex	Vortex	Vortex	Vortex
Solids passage (mm)	40	40	40	40	40	40	40	40
Motor power * (kW): P ₁	1.77	1.69	2.31	3.43	1.10	1.14	2.05	2.40
P ₂	1.20	1.20	1.70	2.60	0.70	0.80	1.45	1.80
Rated current (A)	8.22	3.29	3.97	5.64	4.8	2.0	9.0	4.1
Rated voltage (V)	220-240 1~	400 3~	400 3~	400 3~	220-240 1~	400 3~	220-240 1~	400 3~
Speed (r/min)	2900	2900	2900	2900	2900	2900	2900	2900
Cable ** (HO7RN-F)	4G 1.5	4G 1.5	4G 1.5	4G 1.5	3G 1.0	4G 1.0	3G 1.0	4G 1.0
Pump weight (kg)	34	34	34	40	14	14	17	20

* P₁ = Power at mains. P₂ = Power at motor shaft. **Special rubber compound, free-end cable.

Single phase versions require a start-and-run capacitor when operated without control panel.

When fitting MF and AS pumps, an MF/AS adaptor kit is required.

Data for alternative voltages available on request.

Performance curves 50 Hz

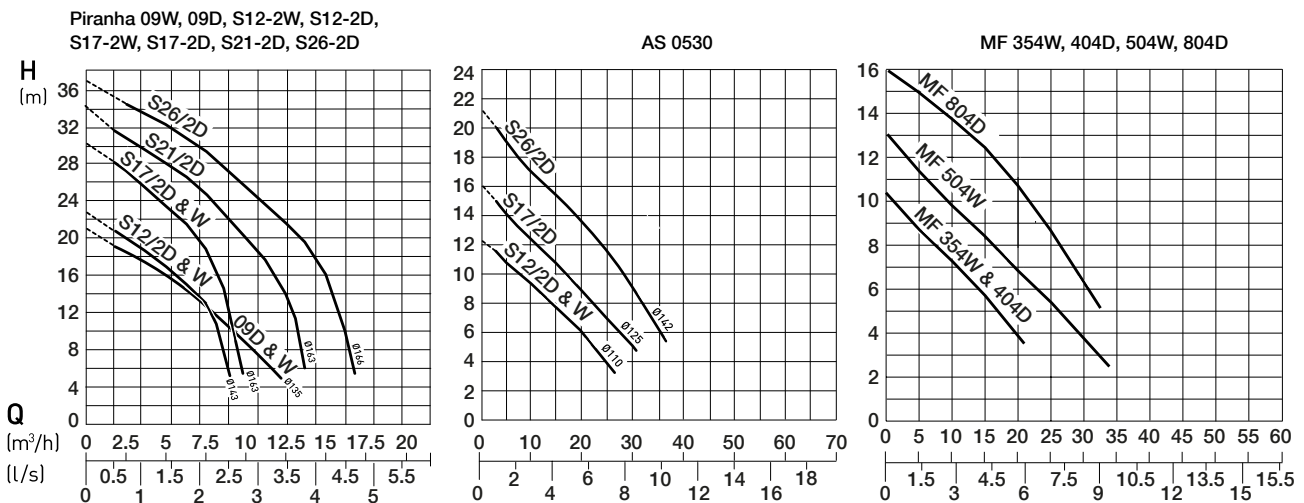

H = Total Head; Q = Discharge Volume. Curves to ISO 9906 (60 Hz available on request) N.B. please use the ABSEL program to validate pump selection.

Installation

Attention to the backwash level is of vital importance for effective dewatering. All outflow points located below the backwash level must be protected against back flow according to standard EN 12056.

1. Ventilation pipe to be brought above roof level
2. Sulzer control panel
3. Concrete lid on cast iron frame
4. Inflow port DN 200
5. Flushing connection and vacuum breaker
6. Venting / Cable outlet DN 100
7. Inflow port DN 150
8. Level control
9. High level coupling supported on cross-beam
10. Discharge pipe
11. Shut-off and ball type non-return valve(s)
12. Sulzer submersible pump
13. Odour filter

* Backwash level

** Backwash loop with base above the backwash level.

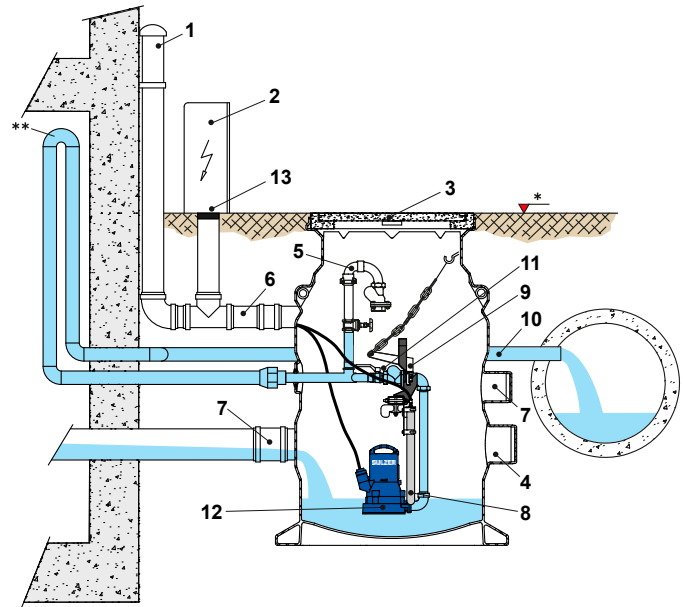

Inlet diameters

Ø	(mm)
DN 100	+0.3 Ø 110 -1.0
DN 150	+0.4 Ø 160 -1.5
DN 200	+0.5 Ø 200 -1.5

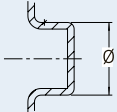

Dimensions (mm)

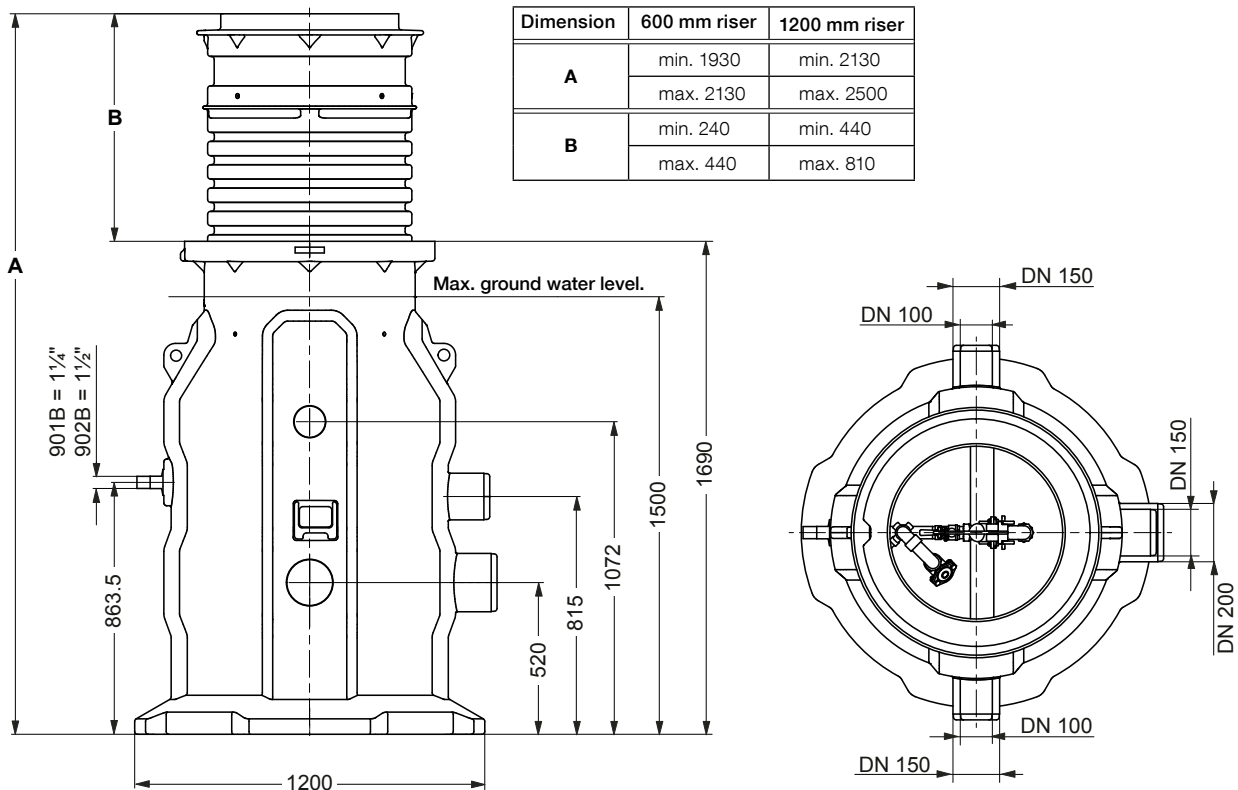

Accessories

SYNCONTA 900 ACCESSORIES				
Riser:		No Riser	Riser Kit 600 mm (62665493)	Riser Kit 1200 mm (62665494)
Size:		1690-1930	1930-2130	2130-2500
				
Basic Lid Kit	62665492	✓	X	X
Class A15 Lid	14995000	✓	X	X
Class B125 Lid	310100110001	✓*	✓	✓
Class D400 Lid	310100109001	X	✓	✓
80 mm Ring **	44505000	✓	X	X
Pressure Pipe Kit	62665491	✓	✓	✓
Float Kit	310100117200	✓	✓	✓
Sensor Kit	310100118200	✓	✓	✓
MF/AS Adaptor Kit	62665495	✓	✓	✓
Service Bar Kit	310100015200	✓	✓	✓
Plasson Adaptor 1¼"	13740039	✓	✓	✓
Plasson Adaptor 1½"	13740042	✓	✓	✓
Flushing Kit	61185001	✓	✓	✓
Vacuum Breaker	61180521	✓	✓	✓
Pump		DN 32 (Piranha 09-S26) DN 50 (AS 0530 / MF 354-804)		

* When fitting to a tank without a riser a single 80 mm ring (part no.44505000) must first be fitted to support the B125 lid.

** Maximum of one ring when used with the B125 lid. Maximum of three rings when used with the A15 lid.

Control unit available for internal or external installation.