

SULZER

Polymer production technology





Production of polymers using static mixing technology

Sulzer Chemtech is the world's most renowned supplier of equipment and related solutions in the field of static mixing. The combination of engineering expertise and many years of application know-how enables Sulzer Chemtech to provide global solutions for improved polymer product quality. All Sulzer Chemtech products and services rely on a successful integration of three main competencies:

- Static mixing know-how
- Piloting and scale-up
- Process and equipment engineering

Reaction technology

Devolatilization technology

Upgrading technology

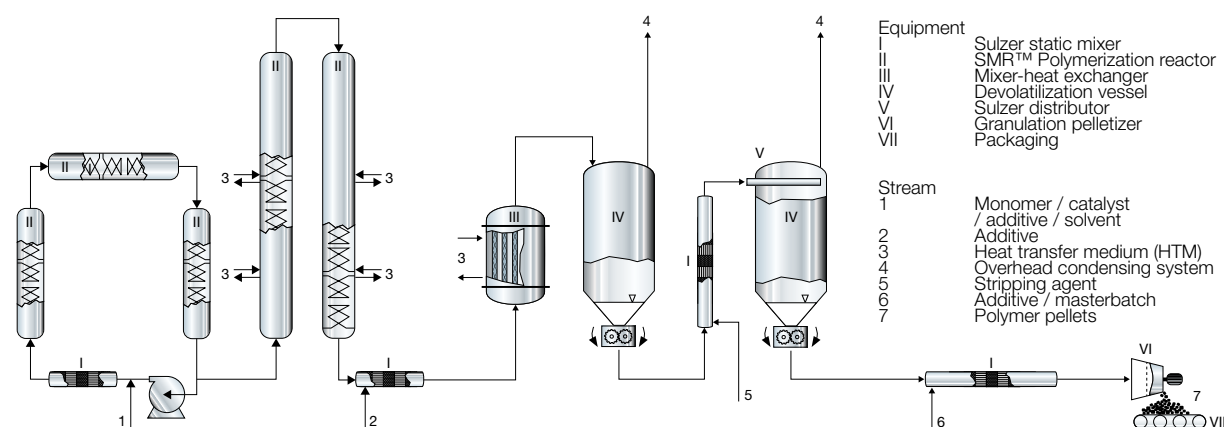

Sulzer Chemtech has developed and introduced a new generation of reactors based on the principle of static mixing for the continuous bulk polymerization, e.g. mass- and solution polymerization. These reactors, called SMR™ (Sulzer Mixing Reactor) are characterized by accurate control of heat transfer and mixing effects allowing high conversion and consistently high polymer quality.

In most of polymer production, devolatilization is a key step since the polymerized product still contains a certain amount of un-reacted monomers, oligomers, solvents, and other impurities. Sulzer Chemtech has developed a static devolatilization technology for the removal of these residual volatiles that uses less energy than conventional systems, prevents product degradation and allows the industry and legal requirements for polymers to be met.

After devolatilization, additives can be mixed into the polymer in order to upgrade the final product. Sulzer has years of experience in providing successful upgrading solutions based on static mixers for improved product quality and profitability. Our extensive reference list includes examples of complex applications with regard to differences in viscosity, mixing ratio and homogeneity.

Mixer based reaction technology

Sulzer's unique polymerization technology based on Sulzer Mixer Reactor (SMR™) opens up new opportunities for process intensification in terms of high conversion, high throughput, consistently high polymer quality, and accurate control of heat transfer, for both oil-based and bio-polymers.

The Sulzer Mixer Reactor (SMR™) is a development based on many years of testing and experience in a variety of viscous applications. This design has been proven successfully in several industrial cases.

The unique tube layout in each tube bundle is similar to that of a static mixer geometry, this allows a homogenous polymer flow on the shell side and the formation of laminar layers in viscous streams. This effect enhances the heat transfer to and from the polymer melt and combines well with the extraordinarily high surface area per unit volume, making the SMR™ plus one of the highest performing reactor / heat exchanger in the industry.

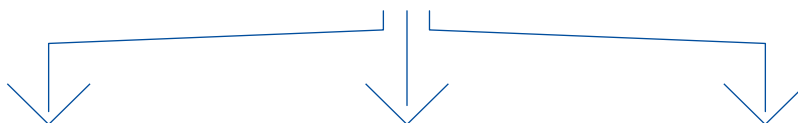
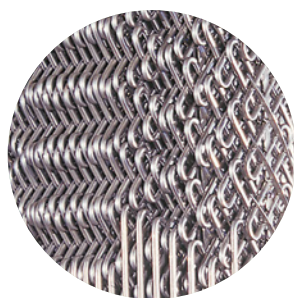

Loop reactor

Individual SMR™ reactors can be configured into a loop reactor and are especially used for highly exothermic reactions. Thanks to an extraordinarily high heat exchange surface area, the SMR™ provides reliable heat removal and temperature control of bulk polymerization reactions. The excellent mixing characteristic of the SMR™ ensures the optimal homogenization of local concentration and temperature gradients. As in the common loop reactor set-ups, virgin monomer is continuously fed to the loop while the semi-finished polymer is discharged and conveyed to the downstream sections.

Plug flow reactors

Plug Flow Reactors consists of a set of SMR™ modules built in series thus making separate temperature and mixing zones available to meet varying process requirements for high conversions. As the polymerization process proceeds, the monomer concentration decreases leading to higher polymer viscosity. The SMR™ reactor secures a plug flow regime, even with high viscosity. It also features a narrow residence time distribution that promotes homogeneous polymer quality. This advantage is maintained throughout the spectrum of the changing polymer viscosity, even at high conversion levels.

Heat exchange

Cooling a polymer melt or solution is a difficult task, as the viscosity of the product between inlet and outlet increases. In some cases, this effect may be very pronounced and can lead to maldistribution of the polymer flow between the tubes of a simple multi-tube heat exchanger. Sulzer has extensive know-how in predicting such effects and, by choosing the most appropriate equipment design, is able to find solutions for even the most difficult cooling tasks. A typical application is where it is used as a cooler in fiber production to ensure optimal mixing and homogenization of the melt.

Advantages

Investment

A variety of polymer grades can be produced in one single line due to:

- High and controllable combination of mixing and heat transfer rates
- Capability of processing fluids with a wide range of viscosities

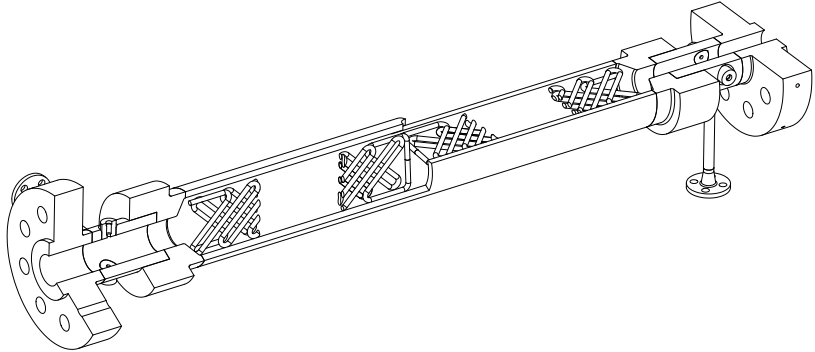

Operating cost

- No rotating parts, low energy consumption
- High conversion rate and reduction of byproducts
- Prevention of large quantity of off-spec product during product grade switch
- Reduced energy requirements
- Fast self cleaning and start-up procedure

Cutaway of the Sulzer SMR™ reactor

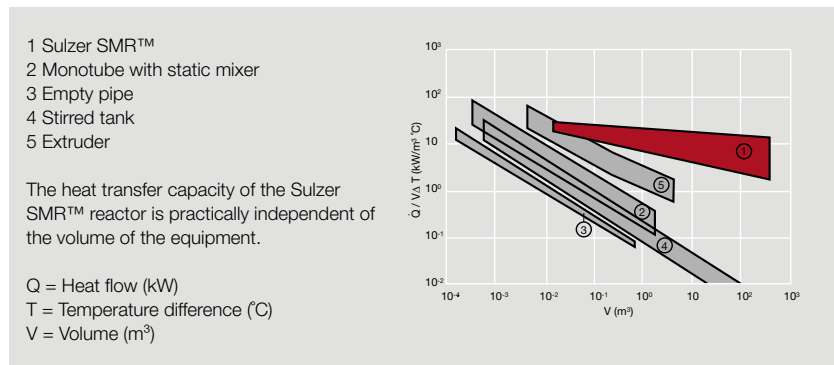

Improved product quality

- Plug flow profile results in narrow residence time temperature distribution with positive impact on the molecular weight distribution
- No channelling / no maldistribution and dead zones
- High conversion and reduction of by-products

Heat transfer capacity of various type of reactors for laminar flow



SMR™ under fabrication



Pilot skid

SMR™ used as plug flow reactor in polystyrene application ready to be shipped to customer



Devolatilization technology

In many cases polymer products still contain significant amounts of volatiles such as unreacted monomers, oligomers, solvents and other impurities that have to be removed prior to selling or further processing.

Sulzer Chemtech has developed a unique process concept based on single or multi stage static devolatilization process which allows to remove volatiles efficiently. This solution is applied successfully to many different polymers from pilot scale up to large scale commercial lines.

The static devolatilization technology can be installed as a single or multiple step process. The number of steps depends on the throughput of polymer and the amount of volatiles to be removed.



Preconcentration

Applied for low viscous product and low polymer content.

The Preconcentration stage could be used in combination with other stages following devolatilization or could stand alone. The process comprises a static mixer/heat exchanger and an expansion vessel for the vacuum degasification.

This step uses the unique feature of the Sulzer SMXL™, heat-exchangers with mixer inserts.

Application:
Elastomers

Monomer recovery

The vacuum degasification offers major benefits of purifying the polymers from residual monomers allowing their recovery. Moreover the process uses low shear forces and avoids temperature overshoot that could degrade sensitive polymers. Depending on the residual monomer and on the polymers, the static devolatilization technology can be installed as a single or multi stage process.

Applications:
PLA, PS and styrenics, PC

From low to ultra-low volatiles

Typically applied to products with high viscosities and low inlet volatile content. This stage can achieve extremely high devolatilization efficiency for a broad range of polymers and viscosities. Special Sulzer Mixer allows consistent heating with very low pressure drop.

The special treatment in this stage could involve the use of stripping if needed.

This step allows reduction of volatiles in the range of ppm.

Applications:
Polyolefins, POE, Solvent based recycling

Advantages

Investment

The capital cost is comparatively moderate due to the unique process concept without moving parts.

Operating cost

- Reduced electrical power consumption as the result of the absence of heavy rotating equipment, e.g. extruder etc.
- Reduced mechanical maintenance

Product quality

- Very low residual VOC levels
- Prevention of degradation due to avoidance of elevated process temperatures and hot spots through efficient heat transfer equipment
- Ideal for sensitive products due to low shear forces in the process



Example of installation

Devolatilization technology (first stage)

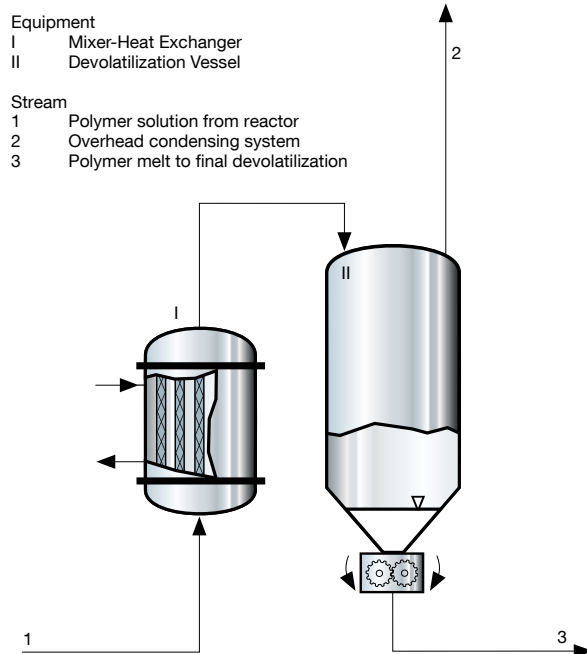

Devolatilization technology (second stage)

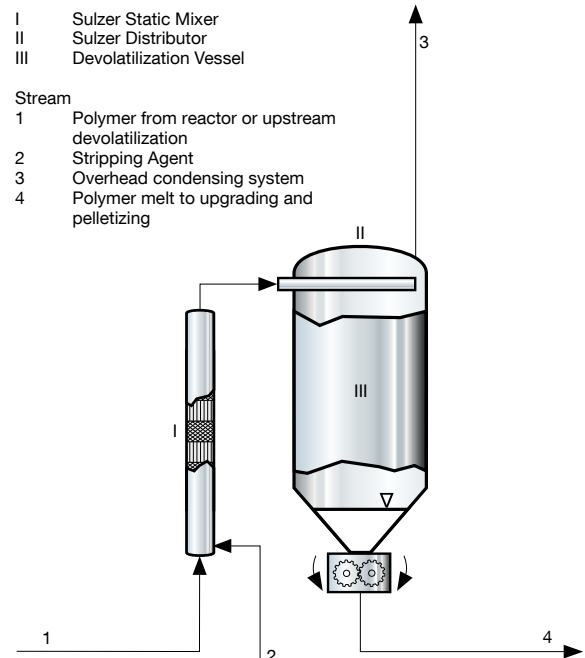

Upgrading technology

After polymerization, additives can be mixed into the polymer melt prior to pelletization, in order to upgrade the final product. Sulzer has many years of experience in providing successful upgrade solutions based on static mixers for improved product quality and profitability of customers' products and processes. Mixing of additives into high-viscosity products is performed in various hydraulic regimes, ranging from laminar to transitional and turbulent. The polymer additive mixing ratio defines the degree of mixing complexity.

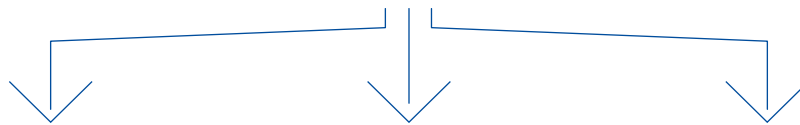
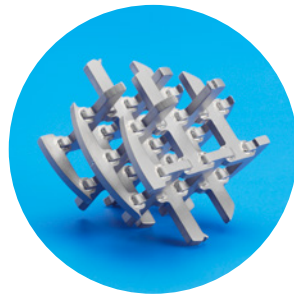

Compounding of two polymers

When two different polymers have to be mixed together to form a compound, very often dynamic systems such as extruders are used. Static mixers, however, show equally good results for compounding of different polymers, while having the advantage of low maintenance costs and spares requirements.

For most compounding tasks, the required shear forces are not very high. Sulzer static mixers are therefore a true and cost-effective alternative for compounding your polymers.

Dispersing additives

Insoluble additives can be perfectly dispersed with Sulzer static mixers. The Sulzer mixer geometry along with Sulzer's special distribution devices have proven efficiency with many industrial references.

The SMX™ or the SMX™ plus static mixer are the reference for homogenization and dispersing tasks in laminar flow. Even challenging mixing applications such as dosing a small amount of low-viscous additive into a high-viscous main stream can be performed very efficiently.

Melt homogenization

To enable stable sheet extrusion or stable pelletization with uniform granules, it is essential that the polymer melt stream is as homogeneous as possible prior to pelletization. This applies to composition, viscosity and temperature. Our SMX™ and SMX™ plus static mixers show optimally equalized gradients of viscosity, temperature and color. Even in existing plants, where space is limited, mixers of various geometries can be installed to provide the desired effect.

Advantages

Investment

Compared to dynamic mixing equipment like extruders, Sulzer static mixing solutions are significantly lower in cost.

Operating cost

Cost related to maintenance of mixer is non-existent.

Product quality

- Prevention of polymer degradation due to low shear stress
- High and continuous homogeneity of additive enriched polymer
- Reduced product degradation due to very short residence time



Sulzer Chemtech side stream mixing system

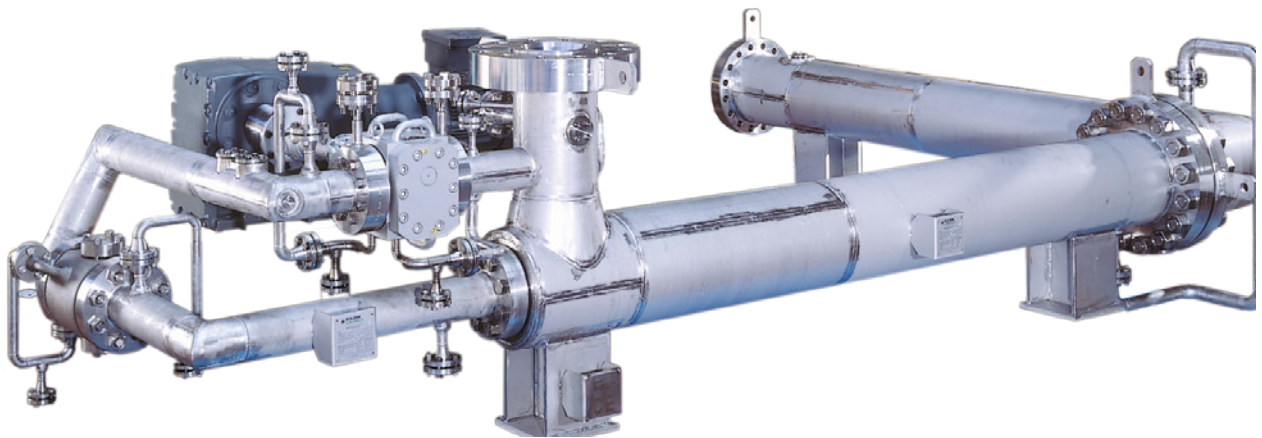

A global specialist at your doorstep

Sulzer serves clients worldwide through a network of over 180 production and service sites and has a strong footprint in emerging markets.

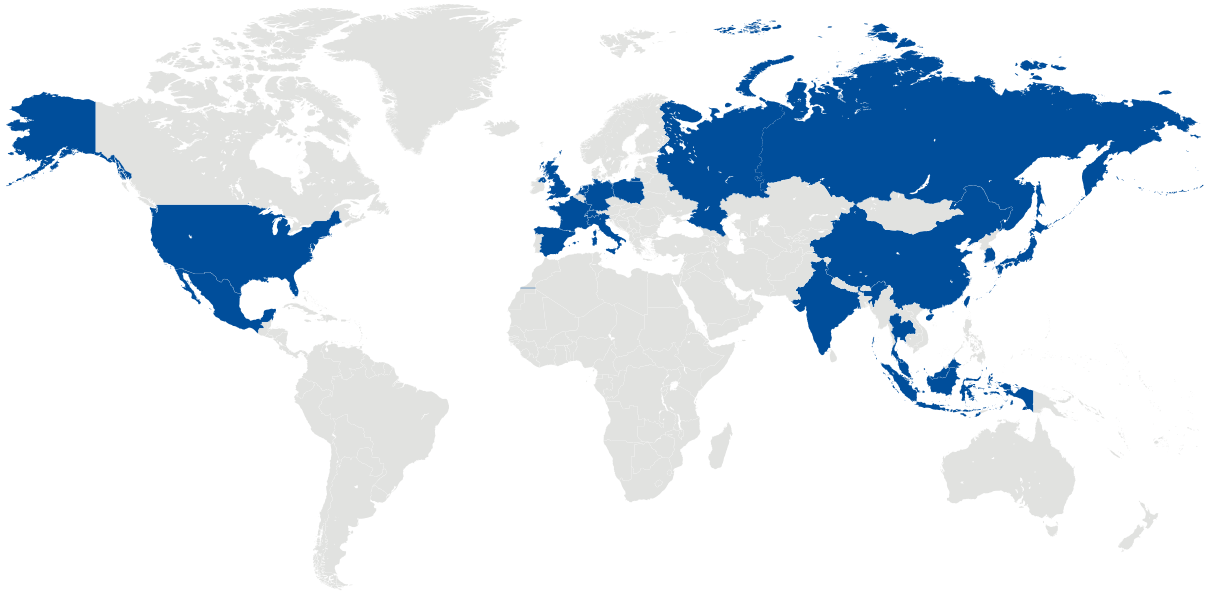

Testing facility

Sulzer operates pilot facilities to develop technologies for polymerization reactions and devolatilization, as well as for mixing and heat transfer in highly-viscous media. We tailor our pilot plants to your requirements and demonstrate both feasibility and scale-up for industrial-scale projects.





Devolatilization unit installed at customer site

The Chemtech division is the global market leader in innovative mass transfer, static mixing and polymer solutions for petrochemicals, refining and LNG.

Chemtech is also leading the way in ecological solutions such as biopolymers as well as textile and plastic recycling, contributing to a circular economy. Our product offering ranges from technology licensing to process components all the way to complete separation process plants. Customer support ranges from engineering and field services to tray and packing installation, tower maintenance, welding and plant turnaround projects – ensuring minimal downtime.

E10558 en 4.2025, Copyright © Sulzer Ltd 2025

This brochure is a general presentation. It does not provide any warranty or guarantee of any kind. Please, contact us for a description of the warranties and guarantees offered with our products. Directions for use and safety will be given separately. All information herein is subject to change without notice.

