

# SULZER

Original spare parts

---

## Service kits for AHLSTAR process pumps



# Save time and costs with service kits

---

When it's time to service a pump, it's helpful to have all your spares ready to go - whether you need O-rings, gaskets, mechanical seals, bearings or other components. Our specially designed service kits make working on your pump faster and easier by offering the components your pump requires in a complete package. Not only will you have the right parts for the job, but you'll also save time and effort.

## The right parts for the job

---

All parts required for a specific service task are available in a single package. Each is clearly marked with its own unique identification number, product type, size and description for ease of reference.

## Easier handling

---

Identification, selection, purchasing and inventory management are simplified as a single stock keeping unit (SKU) replaces a list of individual part numbers for items in the kit. Sturdy packaging and clear labeling make the service kits easy to store and use. The packaging protects the individual items from damage and can be recycled after use.

## High quality parts

---

Pre-packaged service kits simplify maintenance and reduce downtime, while original capital parts such as impellers and exchange units preserve hydraulic efficiency, energy performance and operational safety throughout the pump's full lifecycle.

We offer specially designed service kits for AHLSTAR single-stage process pumps. These kits ensure that maintenance operations for the range are expedited and simplified, all while ensuring a quality repair.



# Service kits for AHLSTAR pumps

## Sideplate service kit AHLSTAR A

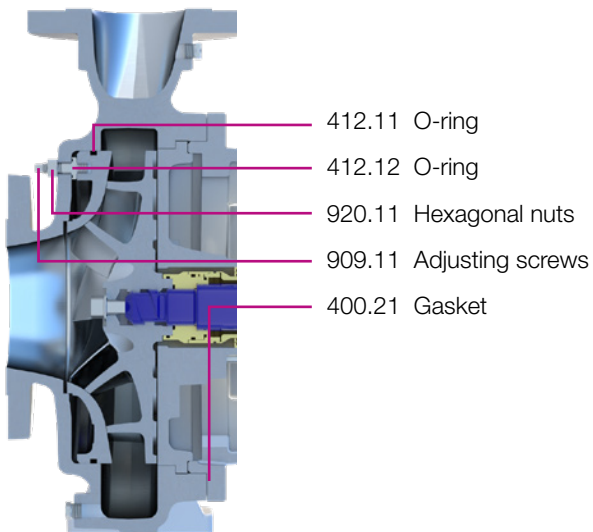

## Sideplate service kit AHLSTAR APP/T, NPP/T, EPP/T, WPP/T

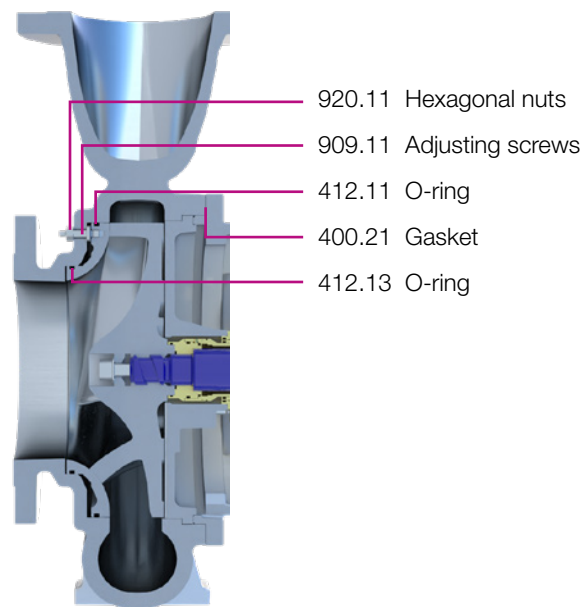

## Impeller service kit

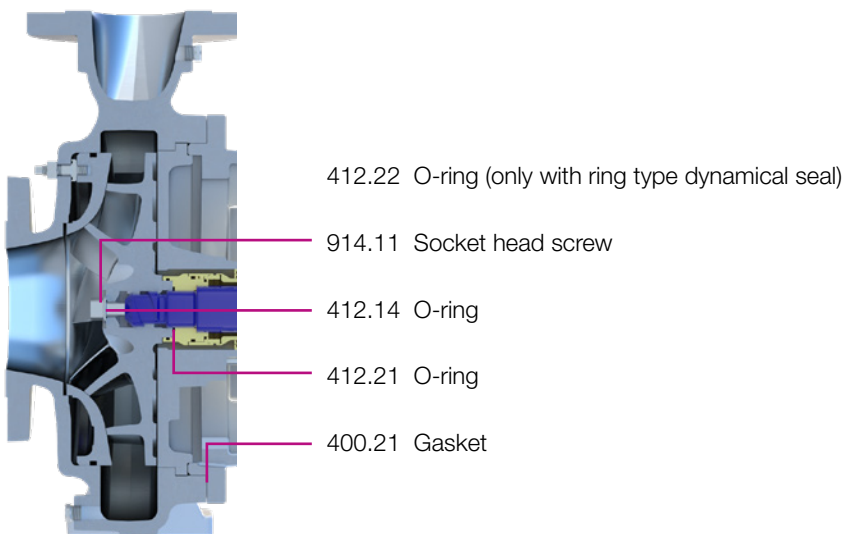

---

## TB1 / TB1F mechanical seal service kits

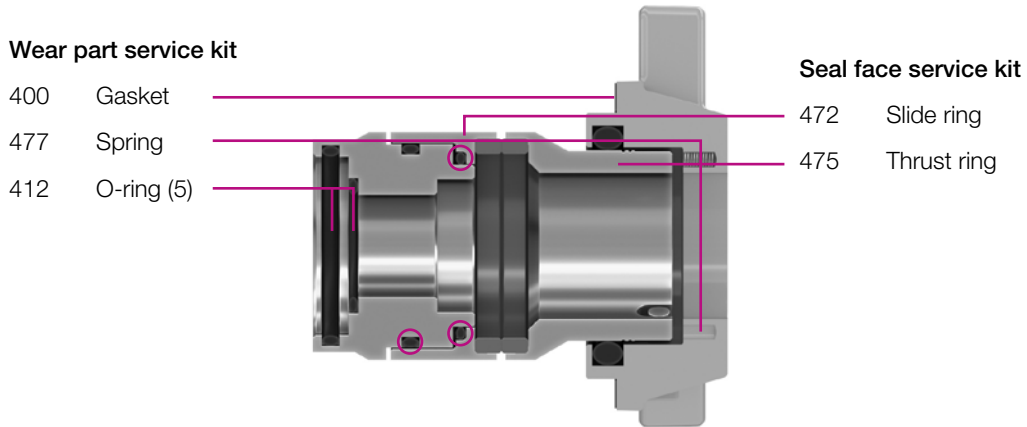

---

## TB2 / TB2P mechanical seal service kits

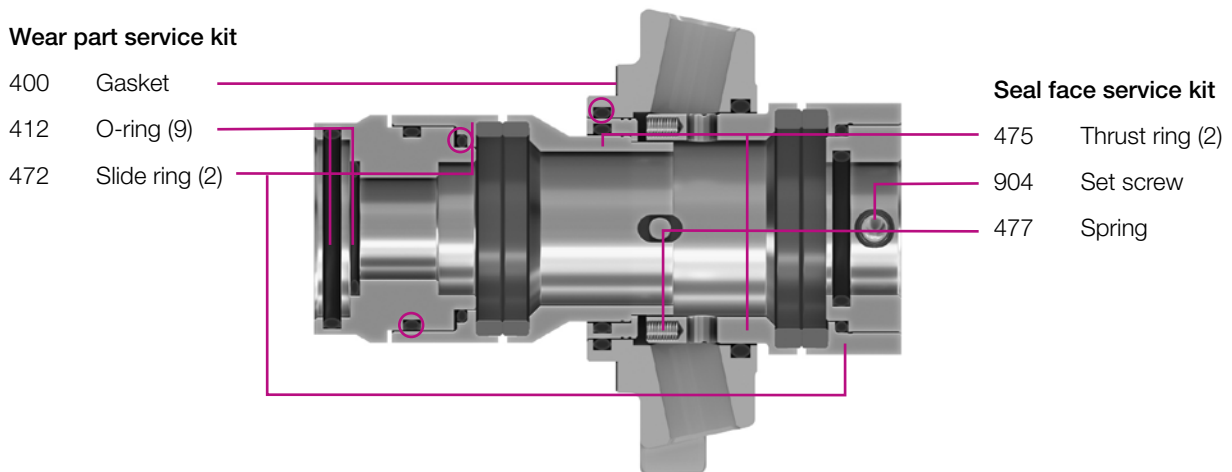

---

## Ring type dynamic seal service kit

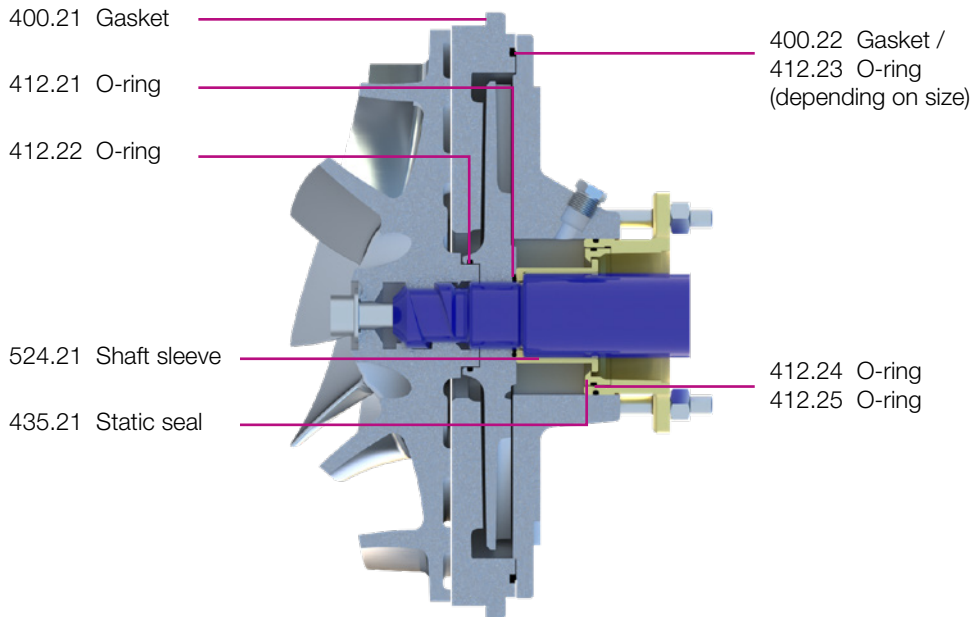

---

## Plate type dynamic seal service kit

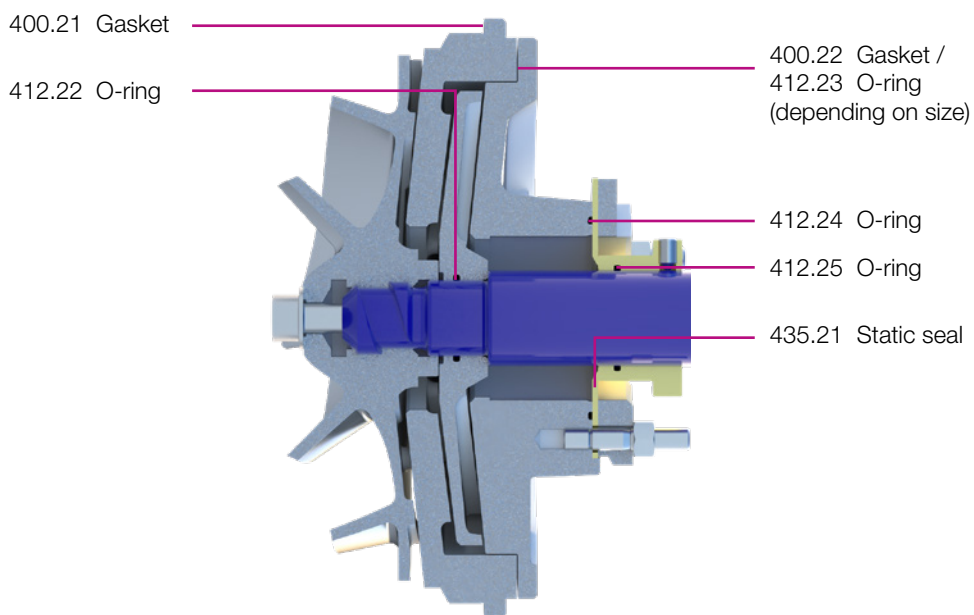

---

## Gland packing service kit

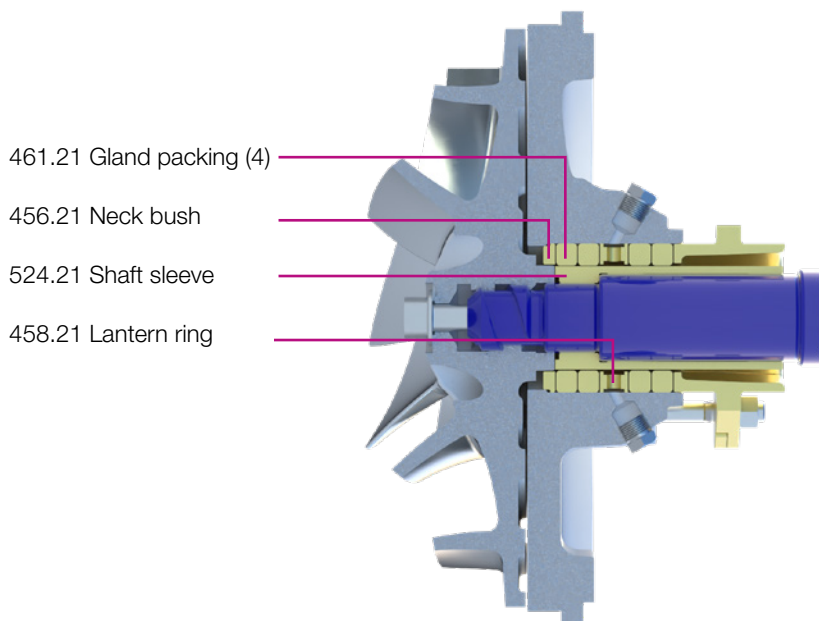

---

## Bearing unit service kit

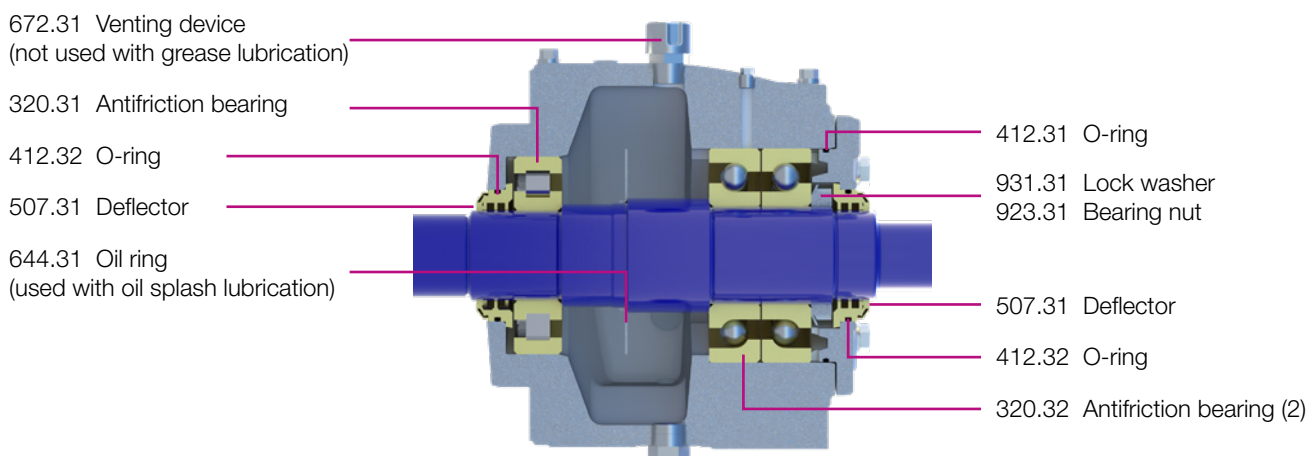

---

> The exact count of spare parts is stated in the IOM.  
> The actual need for spare parts depends on the pump application and conditions.

---

# Service kit recommendations

	Impeller service kit	Sideplate service kit*	Bearing unit service kit	Shaft sealing service kit **	Spare mechanical seal	Exchange unit
Installation & commissioning	●			●	●	
2 years operation	●	●	●	●	●	
Long-term operation	●	●	●	●	●	●

\* When ordering a sideplate service kit, also an impeller service kit is needed.  
 \*\* Depending on the shaft seal fitting, either TB seal service kit, dynamic seal service kit, or gland packing service kit is needed.  
 For servicing the Sulzer TB seal, you can either use a seal service kit or a spare mechanical seal.

See our lifecycle services: [go.sulzer.com/flow-solution-services](https://go.sulzer.com/flow-solution-services)



**The Sulzer Flow division keeps your processes flowing. Wherever fluids are treated, pumped, or mixed, we deliver highly innovative and reliable solutions for the most demanding applications.**

---

The Flow division specializes in pumping solutions specifically engineered for the processes of our customers. We provide pumps, agitators, compressors, grinders, screens and filters developed through intensive research and development in fluid dynamics and advanced materials. We are a market leader in pumping solutions for water, oil and gas, power, chemicals and most industrial segments.

---

E11058 en 5.2026, Copyright © Sulzer Ltd 2026

This brochure is a general presentation. It does not provide any warranty or guarantee of any kind. Please, contact us for a description of the warranties and guarantees offered with our products. Directions for use and safety will be given separately. All information herein is subject to change without notice.

