

BlueLinQ Pro Controller (EC 541)

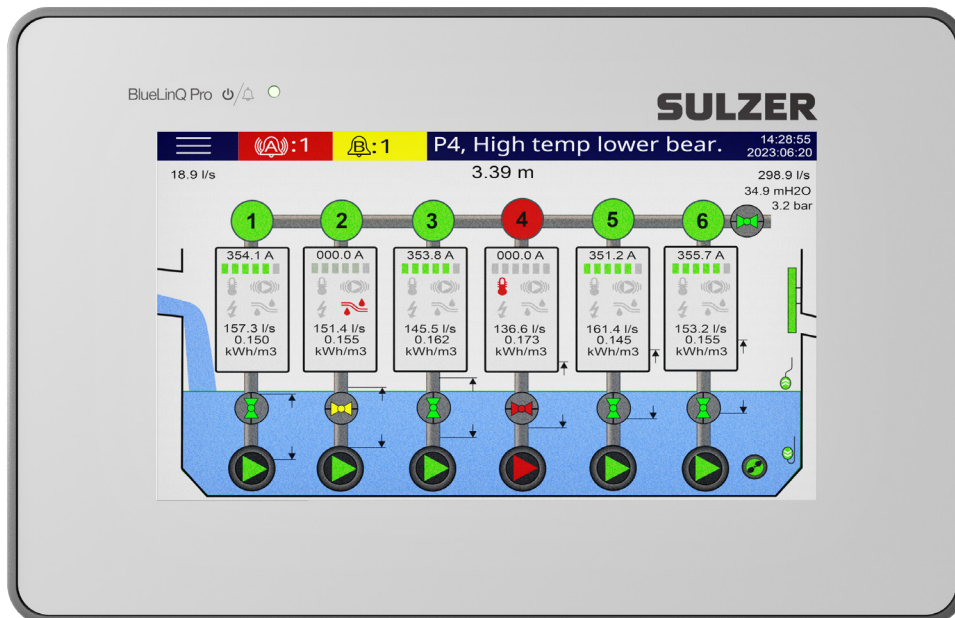

Copyright © 2024 Sulzer. All rights reserved.

This manual, as well as the software described in it, is furnished under license and may be used or copied only in accordance with the terms of such license. The content of this manual is furnished for informational use only, is subject to change without notice, and should not be construed as a commitment by Sulzer. Sulzer assumes no responsibility or liability for any errors or inaccuracies that may appear in this book.

Except as permitted by such license, no part of this publication may be reproduced, stored in a retrieval system, or transmitted, in any form or by any means, electronic, mechanical, recording, or otherwise, without the prior written permission of Sulzer.

Sulzer reserves the right to alter specifications due to technical developments.

Contents

About this guide, audience and concepts	6
Text appearing and declaration in this guide.....	7
Glossary and conventions	7
1 Overview of functions and usage	8
1.1 BlueLinQ Pro controller (EC 541)	9
1.1.1 BlueLinQ Pro symbols in the graphic display	9
1.1.2 Screen appears differently with level sensor or floats.....	10
1.1.3 Alarms.....	11
1.1.4 The menus	11
1.2 BlueLinQ modules	12
1.2.1 BlueLinQ DI-12 Module (CA 811) - 12 Channel Digital Input Module	12
1.2.2 BlueLinQ DO-8 Module (CA 821) - 8 Channel Digital Output Module	12
1.2.3 BlueLinQ AI-6 Module (CA 831) - 6 Channel Analog Input Module	13
1.2.4 BlueLinQ AO-6 Module (CA 841) - 6 Channel Analog Output Module.....	13
1.2.5 BlueLinQ TI-6 Module (CA 832) - 6 Channel Temperature Input Module	14
1.2.6 BlueLinQ LI-6 Module (CA 861) - 6 Channel Leakage Input Module.....	14
2 Configure the BlueLinQ Pro controller (EC 541)	15
2.1 System setup - general information	15
2.2 Communication	16
2.2.1 USB port	16
2.2.2 RS485 ports.....	16
2.2.3 RS232 port.....	17
2.2.4 Ethernet ports (RJ45)	17
2.2.5 Field bus modules (RS485)	18
2.3 Configure the digital inputs, digital outputs, analog inputs and analog outputs	18
2.4 Pump pit settings	19
2.4.1 Station flow (recommended parameters).....	20
2.4.2 Overflow (optional parameter)	20
2.4.3 Pit alarms (some parameters are recommended)	20
2.4.4 Pump pit valve	20
2.4.5 Cleaning control (optional parameter)	20
2.4.6 Mixer control (optional parameter).....	20
2.4.7 Drain pump control (optional parameter).....	20
2.4.8 Motor protector auto reset (optional parameter)	20
2.4.9 Level sensor check (optional parameter).....	20
2.4.10 Tariff control (optional parameter).....	20
2.4.11 Level above sea (optional parameter)	20
2.5 Pump settings	20
2.5.1 Common P1-P6	20
2.5.2 Pump 1-6 settings.....	21
2.6 Set log settings and events.....	23
2.7 Set up communications to surrounding units VFD, soft starters and energy meter.....	24
2.8 Set up cleaner, mixer or drain pump (if used).....	24

3	Detailed descriptions of the functions	25
3.1	Pump capacity calculation	25
3.2	Overflow flow calculation	35
3.3	Pump alternation	36
3.4	Pump reversing.....	37
3.5	Speed controlled pumps (VFD)	38
3.6	Best efficiency point pump control	40
3.7	Crash log	41
3.8	Communication	41
3.9	Cross reference table	43
3.10	Clock functions	43
3.10.1	Timer relay	43
3.10.2	Count down timer	45
3.11	Valve control	49
3.11.1	Pump valve	49
3.11.2	Pump pit valve	51
3.11.3	Alarm valve error	53
3.12	IO controlled data	54
3.13	SD-card/functionality	58
4.	Further explanations of functions of the analog and digital input and output signals	61
4.1	Digital in: personnel alarm and local mode	61
4.2	Digital in: block operation	61
4.3	Digital out: data register set point	61
4.4	Digital out: logic IO	62
4.5	Digital out: auto reset alert	62
4.6	Analog in: outlet pressure	63
4.7	Analog out: data register and data register 2's complement	63
5.	Appendix: BlueLinQ Pro Menu Guidelines	65
5.1	Manual control	66
5.2	Alarm and event lists	66
5.3	Quick status: System	67
5.4	Quick status: Pump pit	68
5.5	Quick status: Pumps	70
5.6	Quick status: Digital inputs	75
5.7	Quick status: Digital outputs	75
5.8	Quick status: Leakage inputs	75
5.9	Quick status: Analog inputs	76
5.10	Quick status: RTD temperature inputs	76
5.11	Quick status: Analog outputs	77
5.12	Detailed status: System	77
5.13	Detailed status: Pump pit	78
5.14	Detailed status: Pumps	80
5.15	Detailed status: PID regulator	82
5.16	Detailed status: Clock functions	82
5.17	Detailed status: Pulse channels	83

5.18	Detailed status: Inputs and outputs	83
5.19	Detailed status: Communication	89
5.20	Detailed status: Field bus modules (RS485)	91
5.21	Settings: System	92
5.22	Settings: Pump pit	94
5.23	Settings: Pumps	97
5.24	Settings: Clock functions	104
5.25	Settings: IO-bit controlled data	105
5.26	Settings: Free user data registers	106
5.27	Settings: PID regulator	108
5.28	Settings: Pulse channels	108
5.29	Settings: Analog logging	109
5.30	Settings: Inputs and outputs	109
5.31	Settings: Communication	118
5.32	Settings: Field bus modules (RS485)	121
5.33	Select language	122
5.34	Calibrate touch screen	122

About this guide, audience and concepts

This guide describes the BlueLinQ Pro controller (EC 541). The equipment controller can either be used stand-alone or communicate values and conditions to a central SCADA system or a web based alarm and monitoring solution like AquaWeb from Sulzer.

Installation guide There is a separate document Installation guide that describes how to physically install the pump controller (printed document in the installation package, and also a PDF on www.sulzer.com).

Audience This guide is intended for system administrators and operators of the BlueLinQ Pro.

Prerequisites This guide assumes that you already are acquainted with those pumps you are set to control and have the sensors connected to BlueLinQ Pro.

The system administrator must also know and decide on the following:

1. The pump controller can either use an analog level-sensor, which measures the water level in the pit, for precise control over start and stop levels, or it can use simple float switches placed at start and stop levels.
 - Float switches can be used in addition to an analog level-sensor, as a backup, and as an additional alarm input.
 - An analog level-sensor has several advantages over float switches: it is more robust (cannot get stuck or be mechanically jammed); it is more accurate; it is more flexible (the start and stop levels can easily be changed); you can get readings of the water level in the pit, the inflow, overflow and the pump capacity; you can optimize the pump performance in various ways, including exercising, alternative stop levels, tariff control etc.
 - It is also possible to employ an alternative stop level, usually a lower level than normal, that is effective once after a number of pump starts. This can be useful if it is desirable to “completely” empty the pit once in a while.
2. You need to know if the pump(s) should be exercised in case of long idle periods. If the installation has one or two pumps, you need to decide if the pumps should alternate.
3. If the electricity has daily varying tariffs, you must know the times of high / low tariffs.
4. You must know how overflow will be measured: if it will be measured using both an overflow detector (to detect the start of the overflow) and a level sensor (to measure the actual flow), you must know the parameters (exponents and constants) to be entered as settings so that the overflow can be accurately calculated by the BlueLinQ Pro.
5. You need to know which alarm class, A-alarm or B-alarm (see Glossary and conventions), to assign each alarm.

Reading guide For installation, see the separate document Installation guide, which covers BlueLinQ Pro. Before you make any settings, or use the control panel, read [chapter 1 Overview of the display symbols](#) —it describes the general functionality and the meaning and usage of the controls on the panel.

The system administrator must ensure that all settings according to chapter 2 Setup the BlueLinQ Pro are suitable for your application.

NOTE! *The default settings are listed in the Installation guide.*

Text appearing and declaration in this guide

Most settings in chapter 2 only apply to the system administrator, but the following also apply to those who operate the controller: language selection, date and time settings, units, backlight time-out, buzzer, operator passcode, start / stop levels.

Glossary and conventions

To designate a menu item in a hierarchy, an angle bracket is used to separate the levels. Example: Settings > System means the menu item you reach by first choosing the menu item Settings, which has a number of submenus, where you choose the menu item System.

Text in blue indicates a hypertext link. If you read this document on a computer, you can click on the item, which will take you to the link destination.

- Pump exercising** Long idle periods in a corrosive contaminated environment are not good for pumps. As a countermeasure, they can be “exercised” at regular intervals, which will reduce corrosion and other detrimental effects.
- Alarm class** The alarm class can be either A-alarm or B-alarm. A-alarms are those that require immediate action, so operational staff in the field should be alerted regardless of the time of day. B-alarms are less important, but should be taken care of during normal work hours.
- Digital in** A signal that is either ON or OFF (high or low), where high is anything between 5 and 35 volts DC, and low is anything below 2 volts.
- Digital output** A signal that is either ON or OFF. At ON condition output current is sourced from the power supply and the output is high (~V+). At OFF condition the output is low but it cannot serve as a drain function (no output current). Are typically connections to relays.
- Analog output** Signal in the range 4-20 mA. Sourced from power supply.
- Analog input** Eight analog inputs used for connecting sensors. **Ain:1** to **Ain:4** are 4-20 mA inputs. **Ain:5-Ain:6** are configurable for Pt100 and PTC. **Ain:7-Ain:8** are configurable for or Pt100 and Leakage.
- Pump reversing** The controller can reverse the pump if the necessary external equipment is installed in the station. The controller can reverse the pumps on number of occasions, e.g. low capacity, pump fail, fallen motor protector, over currents and after number of starts
- RS485 modules** Refer to surrounding units connected to the RS485 bus, e.g. soft starters, VFDs, and an energy meter or to a surveillance system like a SCADA

1 Overview of functions and usage

BlueLinQ Pro is designed to control 1-6 pumps. It can operate a pump station stand alone and / or within a surveillance system together with some communication equipment. For configuration and operator interaction, use the menus which can be selected tapping on the screen, Enter and Esc keys. With the AquaProg software, configuration and back up of settings can be stored on a PC.

Add a Sulzer dedicated modem to create a full remote alarm and monitoring solution, together with an AquaWeb rental contact or by any SCADA system.

BlueLinQ Pro base unit is the module with the 7" touch screen. This unit can work alone or adding more subunits to expand the I/O signals. The base unit has 4 digital inputs and 4 digital outputs. Communication ports are two RS485 ports and one of each of USB, RS232 and a RJ45 Ethernet port. BlueLinQ Pro unit also has a MicroSD memory slot.

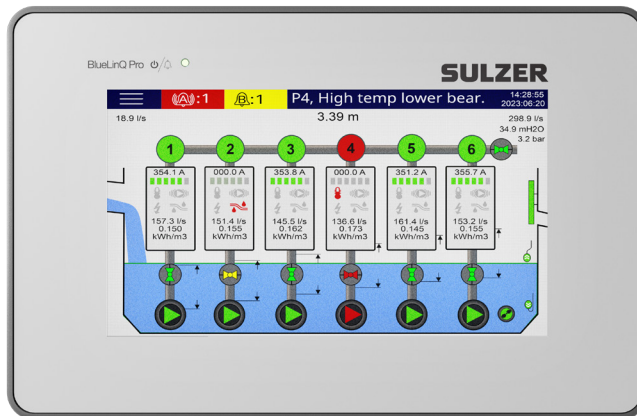

Figure 1.1: Base module BlueLinQ Pro

Expansion I/O modules

A BlueLinQ Pro system as a base unit can be expanded with multiply I/O-units to meet the needs of today and tomorrow. There are possibilities to have up to max 32 expansion various units and 9 of each kind of the following units in one BlueLinQ Pro system:

BlueLinQ DI-12 Module (CA 811)	12 Channel Digital Input Module
BlueLinQ DO-8 Module (CA 821)	8 Channel Digital Output Module
BlueLinQ AI-6 Module (CA 831)	6 Channel Analog Input Module
BlueLinQ TI-6 Module (CA 832)	6 Channel Temperature Input Module
BlueLinQ AO-6 Module (CA 841)	6 Channel Analog Output Module
BlueLinQ LI-6 Module (CA 861)	6 Channel Leakage Input Module



Figure 1.2: Extension modules

The system can be complemented with modem to communicate to a surveillance/SCADA system.

Sulzer wireless modem (max. 1 unit/system)

Other protocol converters are available on the open market.



Figure 1.3: Sulzer Modem

1.1 BlueLinQ Pro controller (EC 541)

The BlueLinQ Pro controller is the heart of the BlueLinQ Pro system. The default screen (top-level view) of the display on the BlueLinQ Pro controller dynamically shows the operating status of the pumps and conditions in the pit, displaying just about everything you need to know about the current situation. Figure 1-1 shows symbols and explains their meanings. The unit will always revert to this view after 10 minutes of inactivity in any other view (such as showing menus or submenus).

In the submenus you can always return to the default screen by pressing ESC.

Power and Alarm LED

- Green:
Power On -No active alarms
- Red blinking:
Non acknowledge alarm/s is active
- Red solid:
At least one acknowledged alarm is active,

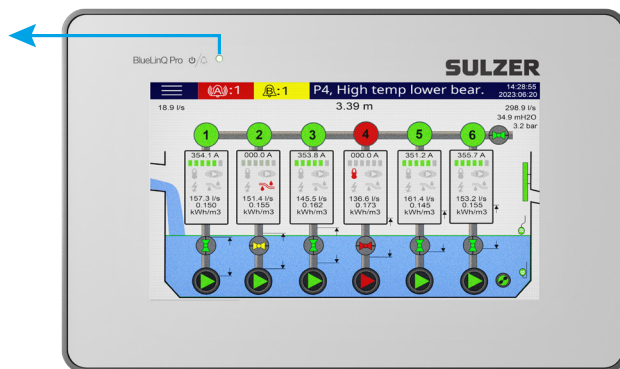

Figure 1.4: Power and alarm LED

1.1.1 BlueLinQ Pro symbols in the graphic display

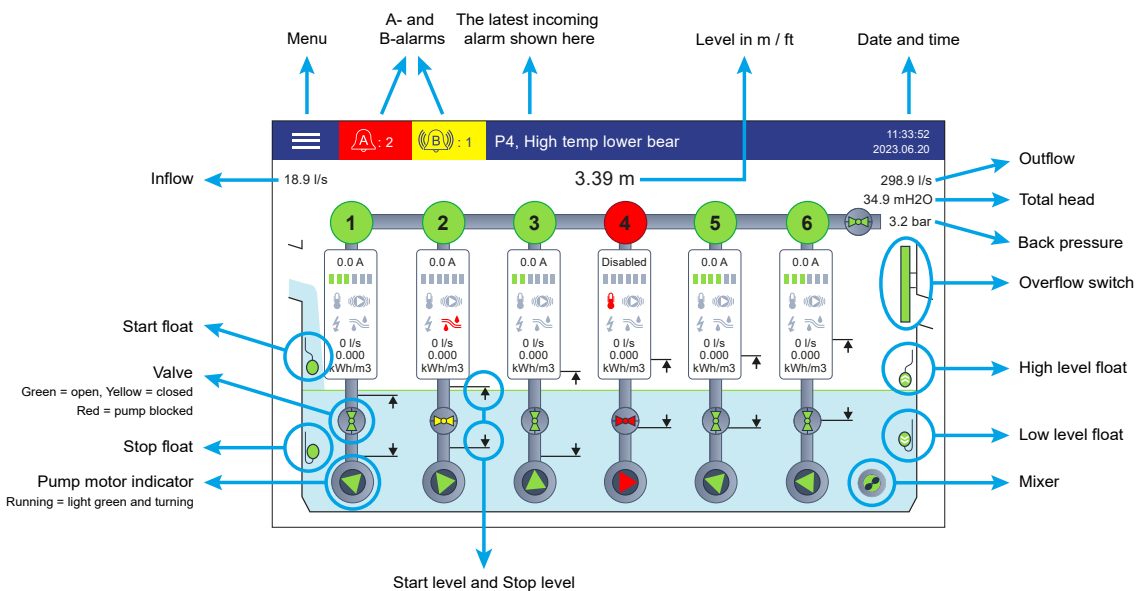

Figure 1.5: Graphic display

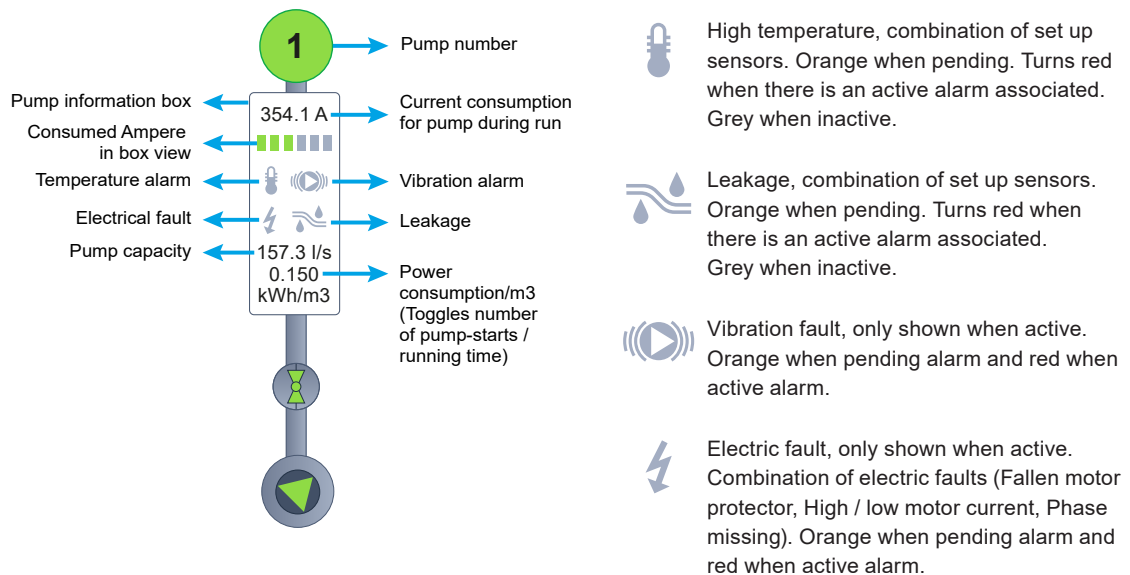

Figure 1.6: Graphic display - pump line

1.1.2 Screen appears differently with level sensor or floats

The top screen appears differently depending on if there is a level sensor in the system or not. There is no level value presented if the pit is without a level sensor. If no analog input is dedicated for Level sensor, the controller assumes there are Start / Stop floats. The start / stop floats are animated and must have a dedicated input if they are to appear on the display.

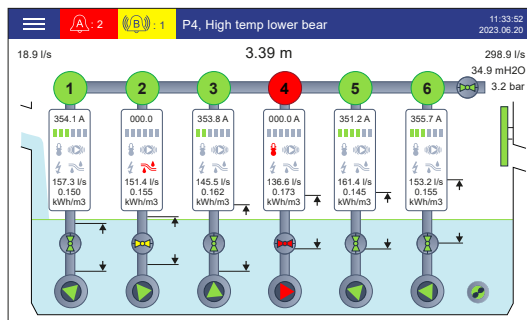

Figure 1.7: Appearance with level sensor

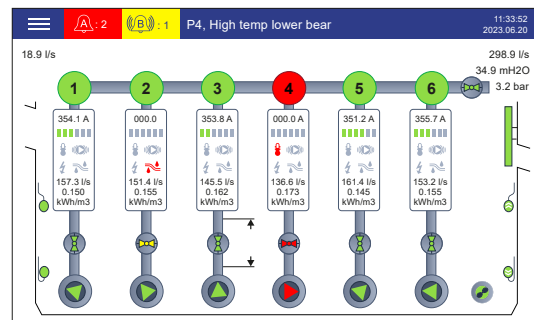

Figure 1.8: Appearance with start/stop floats

Level and the dynamic field

If level sensor is installed on one of the analog inputs, the height of the level in the pit is presented, shown with two decimal places, and by means of a visual water level indicator on the graphics display. Level can be referenced from sea level (if set). If there is a high-level alarm setup and it gets activated, the dynamic field turn into red. If the system runs on floats, no level or visual water level indicator will be shown on the display.

Outlet value on the display

Outflow: After the controller has calculated the pump capacity, a value appears on the display when the pump or pumps run. See the section 3.1 Pump capacity calculation for information on how the calculation is done and which parameters are necessary to set. Outlet pressure: If there is an outlet pressure sensor installed, the value appears on the display. See the section 3.1 Pump capacity calculation for information on how the calculation is done and which parameters are necessary to set.

Floats and overflow sensor on the display

High- and low level floats are green in normal mode. They switch position (animated) and are flashing red when activated. Start / stop floats are gray in non-active mode, and blue when activated. Overflow sensor is green in normal mode, turn to flashing red when activated.

Screensaver

When the screen has been inactive for 3 minutes (default), the screen saver starts. The screensaver has a dark background with a flashing green / red / yellow circle, depending on its' status.

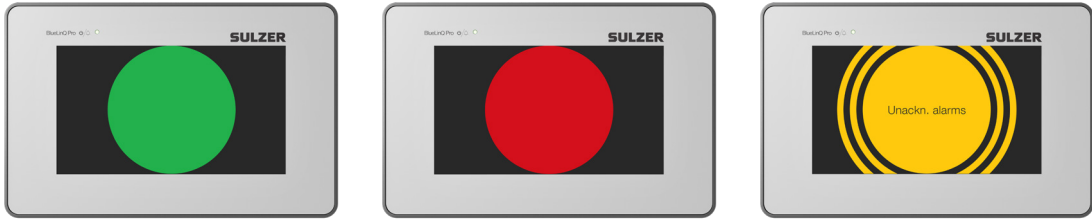

Solid green circle: No active alarms

Solid red circle: At least one active acknowledged A-Alarm

Red circle with brackets: At least one unacknowledged A-Alarm

Solid yellow circle: At least one active acknowledged B-Alarm

Yellow circle with brackets: At least one unacknowledged B-Alarm

1.1.3 Alarms

When alarms occur, the symbols for A-alarm or B-alarm will be colored on the first line in the main screen. If the bell is tremble, that symbolize unacknowledged alarms. The number in the alarm box will say how many active alarms there are and in each category.



One acknowledged active A-alarm. Symbol and alarm text will be shown.



One unacknowledged A-alarm. Symbol and alarm text will be shown.



One acknowledged active B-alarm. Symbol and alarm text will be shown.



One unacknowledged B-alarm. Symbol and alarm text will be shown.

1.1.4 The menus

To enter the main menu, tap the menu symbol in the upper left corner.



Figure 1.9: Menu icon on the BlueLinQ Pro controller screen

From the main menu, the submenus are available.

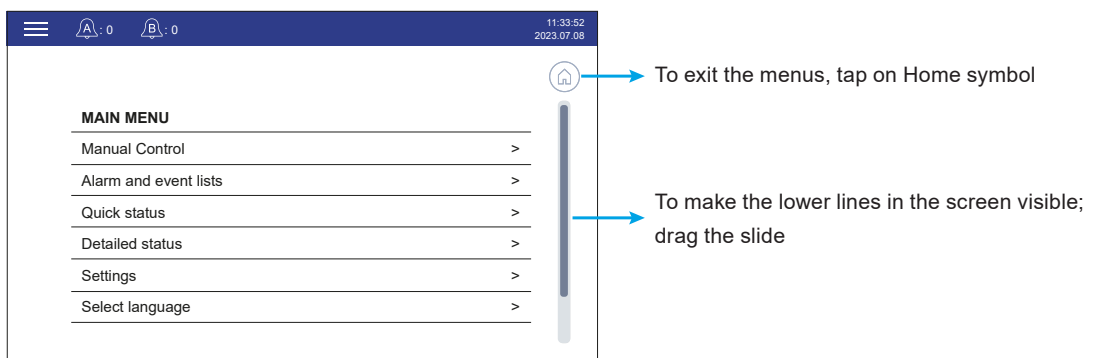

Figure 1.10: BlueLinQ Pro controller main menu screen

1.2 BlueLinQ modules

A maximum of 30 expansion units can be used, in addition to 9 of the following modules:

Note: *The first unit in the system shall have CAN ID = 1, remaining units must have unique IDs in ascending order.*

1.2.1 BlueLinQ DI-12 Module (CA 811) - 12 Channel Digital Input Module

BlueLinQ DI-12 has 12 Digital Inputs in one module. The input voltage must not exceed the BlueLinQ Pro supply voltage.

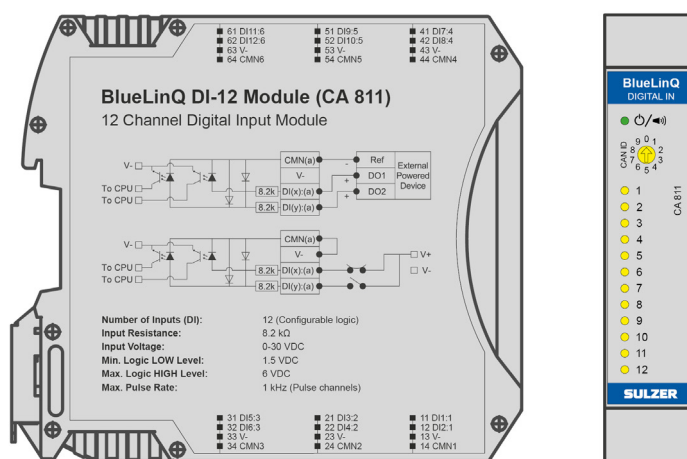

- Every group of 2 inputs are galvanic isolated. Pulse input rate is 1kHz with 50% symmetrical duty cycle.
- Port active and assigned yellow lamp lit
- Port inactive (physical state of port) yellow lamp off
- Port active and not assigned yellow lamp flashing
- PTC or bimetal temperature sensors are connected between V+ and input in series

1.2.2 BlueLinQ DO-8 Module (CA 821) - 8 Channel Digital Output Module

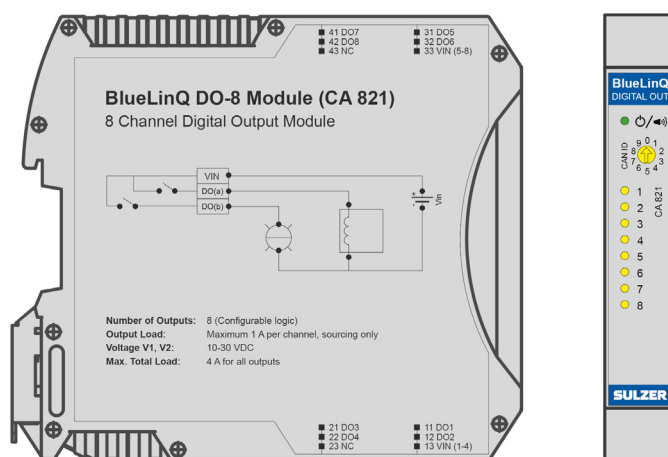

- An alternative supply from the BlueLinQ Pro can be used if there is a risk to the output being overloaded.
- Eight voltage outputs for driving LED's, relays and signaling to other devices. Configurable logic.
- Max. load 1 A/output, max. total load (8 outputs) = 4 A.
- < 30 VDC (sourcing from power supply), only sourcing - no drain.
- With address switch in first position, module also works as bus terminator and bus power feeder
- Port active and assigned = yellow LED lit
- Port inactive (physical state of port) = yellow LED off
- Output overloaded = yellow LED flashing

When power sourcing field bus

- System BusPwr LED when power is within limit = Green
- Critical low = Red flashing
- Power save activated = Orange

1.2.3 BlueLinQ AI-6 Module (CA 831) - 6 Channel Analog Input Module

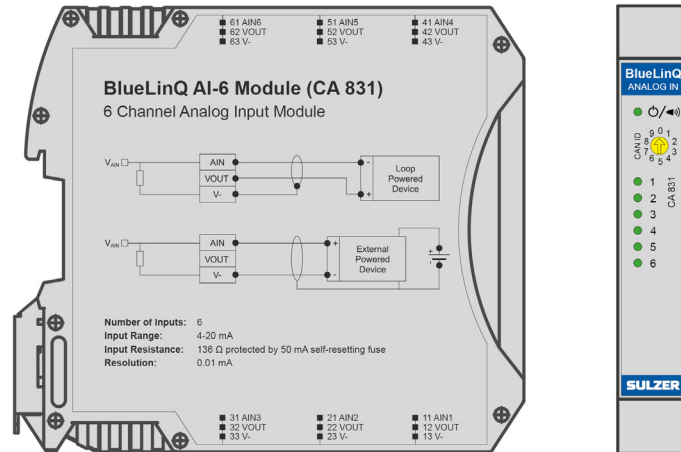

- Six current inputs for sensor 4-20 mA signaling interface. Sample frequency 10 Hz, 0.5 % Accuracy.
- Port active and assigned = green LED's lit
- Port unassigned = LED's off
- Open loop or over current (and assigned) = green LED flashing
- Current flowing and unassigned = green LED flashing

Note: The recommended connection cable is twisted and shielded

1.2.4 BlueLinQ AO-6 Module (CA 841) - 6 Channel Analog Output Module

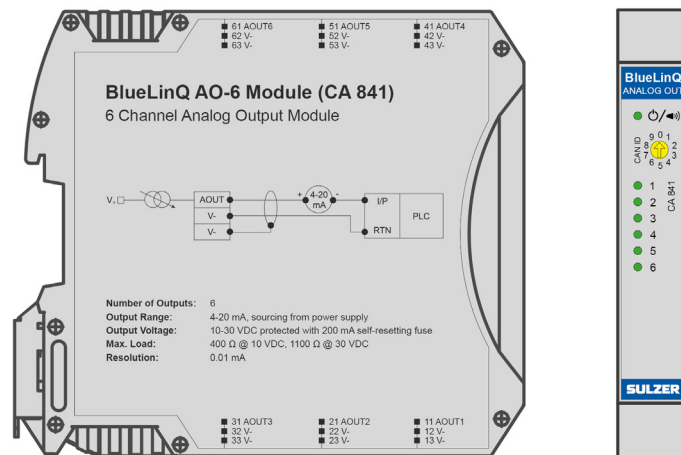

- Six current output 4-20 mA signaling for meters, PID control, etc. Resolution 1 μA, precision 1%
- Indicator LED's on device
- Port active and assigned = green LED's lit
- Port unassigned = LED's off
- Open loop (and assigned) = green LED flashing
- Current flowing and unassigned = green LED flashing

Note: The recommended connection cable is twisted and shielded

1.2.5 BlueLinQ TI-6 Module (CA 832) - 6 Channel Temperature Input Module

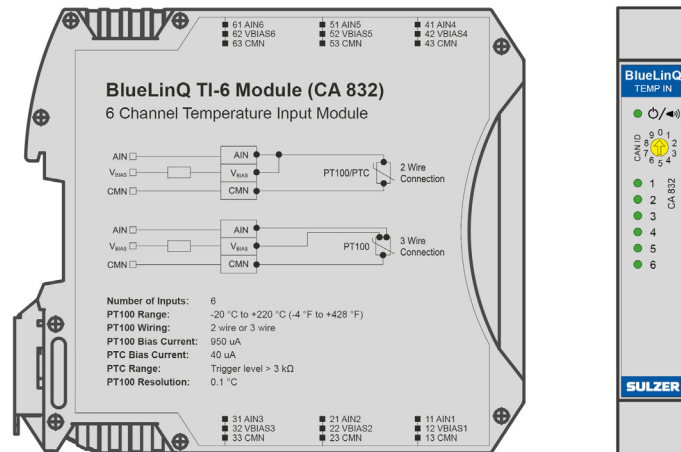

- Temperature sensing, 6 channels three/two wire connection. Module galvanically isolated from field bus. Precision 0.1 %. Pt100 or PTC (bi-metal).
- Indicator lamps on device is working like this
- Port active and assigned = green LED's lit
- Port unassigned = LED's off
- Open loop or shorted (and assigned) = green LED flashing
- Connected and unassigned = green LED flashing

Note: The recommended connection cable is twisted and shielded

1.2.6 BlueLinQ LI-6 Module (CA 861) - 6 Channel Leakage Input Module

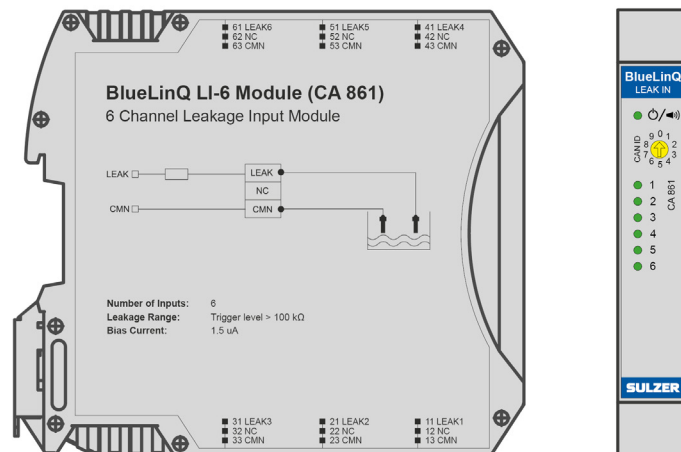

- Moisture or water intrusion detection. Module galvanically isolated from field bus. Uses pulsating output and measures saturation. Default trip value 100 kΩ ± 10 %
- Indicator LED's:
 - Port active and assigned = yellow LED lit
 - Port unassigned = LED off
 - Flashing LED when triggered

Note: The recommended connection cable is twisted and shielded

2 Configure the BlueLinQ Pro controller (EC 541)

Overview of settings

Every station will have its own unique configuration but the procedure to setup the station is similar. This chapter will guide you through the basic settings in the BlueLinQ Pro controller. Note this does not cover all configuration, you must consider your prerequisites.

Before starting to setup the controller, its highly recommended to make a reset of the unit. The BlueLinQ Pro controller reset button is accessed through a small hole on one of the edges. To activate place a straightened paperclip or similar into the hole and hold for 10 seconds, this will restore the unit's configuration to factory default.

The menu item Settings has 12 submenus with many settings that need to be entered by the system administrator (although they all have default values). The notes below are a recommended procedure to setup the BlueLinQ Pro controller

2.1 System setup - general information

2.2 Communication

2.3 Configure the digital inputs, digital outputs, analog inputs and analog outputs

2.4 Pump pit settings

2.5 Pump settings

2.6 Set log settings and events

2.7 Set up communications to surrounding units VFD, soft starters and energy meter

2.8 Set up cleaner, mixer or drain pump (if used)

Each of the 12 submenus under settings are described in separate tables in appendix.

Most of the settings require a passcode for System, except some settings under the submenu System, and the start / stop levels under submenus for the pumps, which only require a passcode for the Operator.

Default passcodes: For operator = 1. For admin = 2.

All the settings can be configured locally from the menus or by AquaProg. The advantage of AquaProg is that you can save the configuration on your PC and easily restore the controller if needed.

2.1 System setup - general information

Here are some important parameters to set:

- Station ID
- Date format
- Metric or US units
- System Alarms
- Appearance of the graphical display
- SD card settings

Station ID is very important if there is a SCADA as a surveillance system communication with the controller. In AquaWeb environment this parameter is crucial.

If personnel alarm is used, here is the time settings for that function.

After setting up the station ID, the recommendation is to setup the communication for facilitate further work with the settings by using Aquaprogram.

2.2 Communication

See section 3.8 for more detailed information.

2.2.1 USB port

The USB port is normally used as a local service port and there shall the connection be done to your laptop/PC. The BlueLinQ Pro USB service port supports USB2.0 and is of Mini-B connection type, see Figure 4 and Table 1 in Installation guide. It is primarily used to download configuration information and updating firmware using AquaProg. The port supports Modbus RTU or Modbus TCP and cross reference in settings. When connecting the BlueLinQ Pro via USB to a PC for the first time a driver appears, just follow the instructions on your PC.

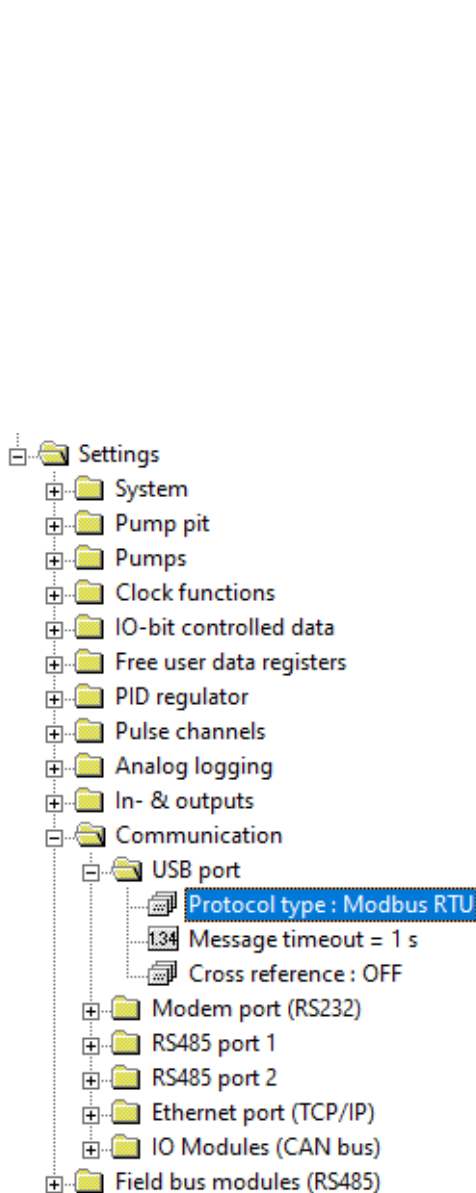

Figure 2.1: AquaProg view of the Communication settings

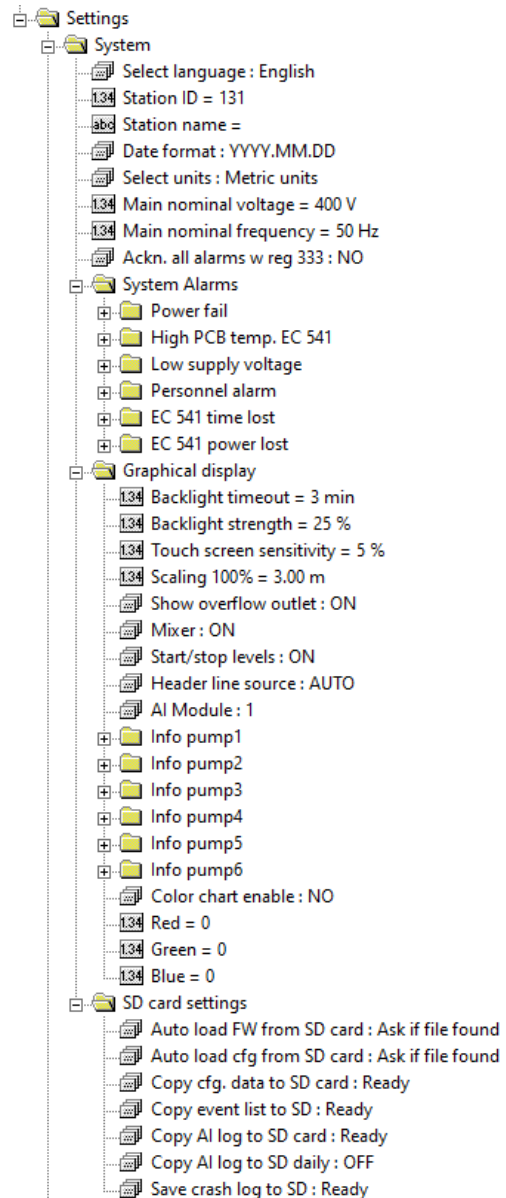

Figure 2.2: AquaProg view of the System settings

2.2.2 RS485 ports

There are two RS485 serial ports on BlueLinQ Pro. They can act as a Master or Slave and use protocol type Modbus RTU or Modbus TCP independently of each other. If there are any Motor Drives or Power monitors connected to BlueLinQ Pro via RS485, the parameters for these must be set in the Section “Field bus modules” further down in this document. Here under the settings for Communication and RS485 port, the baud rate, parity, protocol type and Application protocol must be set. Baud rate, parity and protocol type must harmonize the surrounding units which

communicate with this port. An RS485 communication line must be terminated in both ends. The BlueLinQ Pro has a jumper for termination in the controllers end.

Application protocol:

- If the RS485 port communicates with the motor drives or power monitors, the application protocol must be set as 'Modbus Master'. Poll intervals are usually set to 1 second. If the electrical environment is noisy, this interval can be increased.
- If the port communicates with a SCADA or PLC, the port must be set as Modbus slave and a protocol ID must be set.

Note: *If using 6 motor drivers, it's recommended to put three motor drivers on the first RS485 port, and the other three on port number 2.*

2.2.3 RS232 port

The RS232-port is design for modem and handle Hayes commands which is crucial for 3G, 4G and 5G modems. If using GPRS modem, the application protocol must be GPRS Hayes enable. If other protocol converter is used on the port, the application protocol can be set Transparent.

Other settings are set in relation to the connected device.

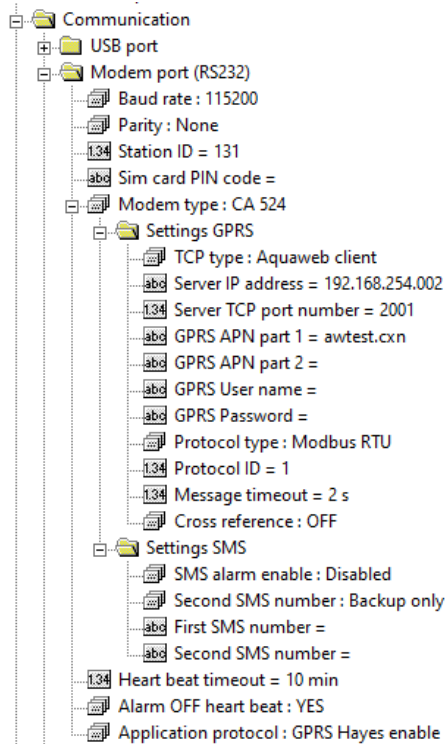

Figure 2.3: Aquaprogram view of the Communication settings

2.2.4 Ethernet ports (RJ45)

The ethernet port handles up to 10 simultaneous connections.

There is an advantage if both ends can communicate with Modbus TCP, the communication speed increases.

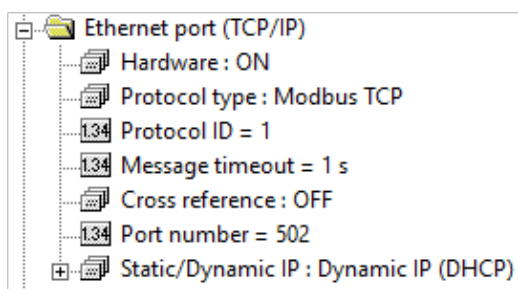

Figure 2.4: Aquaprogram view of the Ethernet settings

2.2.5 Field bus modules (RS485)

Motor drives and power monitor settings are provided in this section.

BlueLinQ Pro supports up to seven power monitors and six motor drives. Ensure a unique Modbus ID is set up on each connected unit.

Select manufacturer and model.

Note: When using both RS485 ports, every unit on the RS485 bus must have a unique ID.

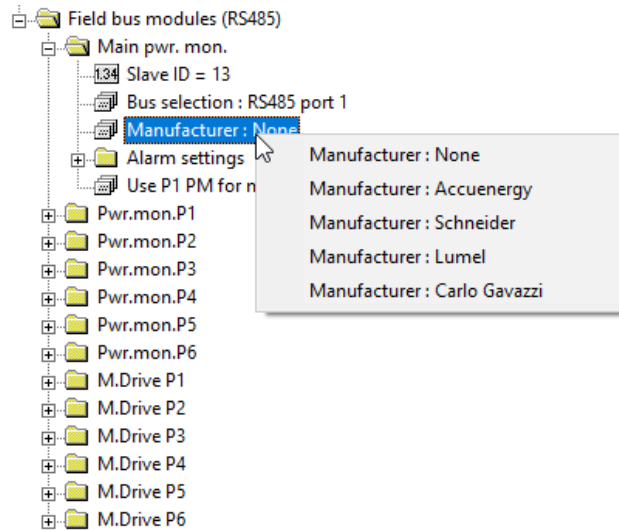

Figure 2.5: Aquapro view of setting for Field bus options:

2.3 Configure the digital inputs, digital outputs, analog inputs and analog outputs

Set designated IO-functions according to the electrical wiring drawing. See your drawings of the station. Under **Settings > Digital inputs**; choose each input and output according to tables 2.1 and 2.2 below.

Table 2.1

Digital inputs
OFF
Run indication
Manual start
Set manual
Set auto
Start float
Pump failure
Motor protector
High motor temp. pump
Leakage pump
Stop float
Low level float
Overflow sensor
High level float
Start float drain pump
Local mode
Alarm reset
Power fail
DI pulse channel 1-4
Block PID controller
Alarm input
Block operation

Table 2.2

Digital outputs
OFF
Pump control
Reset motor protector
Pump fail
Not enough pumps avail.
One pump fail
Mixer control
Drain pump control
Cleaner control
Com timeout control
Remote control
Personnel alarm
High level
Alarm alert
Not acknowledged alarm
Active alarm
Pump reversing
Logic IO
Data register setpoint
Auto reset alert
Valve control
Valve open

Table 2.1

Digital inputs
Leakage mixer-drain pump
High temp. mixer-drain pump
Emergency power mode
Block remote data
Acknowledge pump alarms
Valve open
Valve close

Table 2.2

Digital outputs
Valve close
Time relay
Pulse timer

Under Settings, Inputs and outputs, Analog inputs, Module X, choose each input according to table 2.3 and analog outputs in table 2.4.

Table 2.3

Analog inputs
OFF
Pit level
Motor current
Outlet pressure
Vibration
Outflow meter
Motor temperature
Secondary pit level
Free choice

Table 2.4

Analog outputs
OFF
Pit level
Pit inflow
Pit outflow
Pit overflow
Pulse channel 1-4
PID Ctrl output
Data register
Data register 2-compl.
Set freq. P1-P6

If using temperature modules (BlueLinQ TI-6) and/or leakage modules (BlueLinQ LI-6), select the setting here in accordance to the pump configuration.

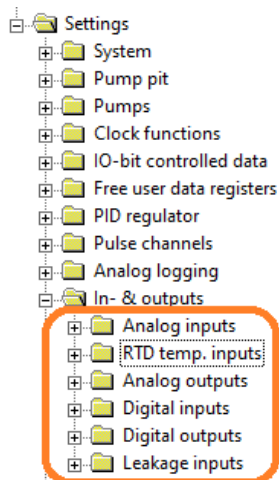

2.6: Aquaprogram view of Analog/digital inputs/outputs settings

2.4 Pump pit settings

It is recommended to set up the pit area under station flow, to ensure the pump calculations perform as accurately as possible. They are bound to energy calculation, pump capacity and outlet calculations. Use the outlet pressure sensor for the most accurate pump capacity and pumped volume calculations

Table 2.5

Pit settings
Station flow *
Overflows
Pit alarms
Pump pit value
Cleaning control
Mixer control

Table 2.5 continued

Pit settings
Drain pump control
Motor protector auto reset
Level sensor check
Tariff control
Level above sea
Free choice

* Necessary for accurate pump capacity calculation

2.4.1 Station flow (recommended parameters)

Under Meas. parameters set the Inflow calculation=ON and your pit shape, also the function Emptying or Filling the pit must be set. System curve at duty point is used if there isn't any Outlet pressure sensor.

2.4.2 Overflow (optional parameter)

Overflow can be detected by an overflow detector (MD 131) or by the certain level. See more information about overflows in section 3.2

2.4.3 Pit alarms (some parameters are recommended)

There are several alarms which can be set under Pit alarms. Each alarm is configurable to be A- or B-alarms. Consult your drawings and verify which are important for your installation. See section 3.7 for further information about crash log.

2.4.4 Pump pit valve

Time settings for the characteristics of the pump pit valve

2.4.5 Cleaning control (optional parameter)

Start on at pump start or pump stop. Configurable running time in second and interval. To disable function; set time and interval to zero. A dedicated digital output controls the cleaner.

2.4.6 Mixer control (optional parameter)

Mixer can be controlled by number of pump starts and/or by a time interval. Require a digital out signal to control the Mixer.

2.4.7 Drain pump control (optional parameter)

Drain pump require a digital input signal allocated as Start float drain pump and a digital output as Drain pump control to control starts and stops of the drain. Drain pump is running in configurable time in seconds

2.4.8 Motor protector auto reset (optional parameter)

Pulse time and delay must be set as maximum number of attempts. A digital output controls the reset.

2.4.9 Level sensor check (optional parameter)

Level sensor check It is possible to check the level sensor reading compared to the installed floats. See the settings under Level sensor check set this up.

2.4.10 Tariff control (optional parameter)

This function is to reduce energy consumption in hours of high cost of energy. You can set this up for separate days in the week.

2.4.11 Level above sea (optional parameter)

If you type in a value here, this value will be added in the pit level but not affect the start/stop levels.

2.5 Pump settings

2.5.1 Common P1-P6

Settings – Pumps – Common P1-P6

To avoid possible station problems this option has many useful functions like, Pump exercising, Pump reversing, Max number pumps running, Min relay intervals, Alternations and Pump blocking.

Pump exercising: It is possible to exercise a pump if required. A maximum pump off time and exercising time can be set. The level must be within the parameters.

Pump reversing: Several parameters can trigger reversing.

Max. number of pump running: To save energy and/or minimize load on the grid.

Min. number of pumps available: Before the alarm: "Min. pump are available"

Min. relay interval: To minimize load on the grid

Pump alternation: See section 3.3.

Pump blocking: Which circumstances shall block the pumps

Calculation pump capacity: Function On or Off, preferences of calculation

Alternative stop level: Start on fast change

Backup run: When High level float activates, dedicated pumps start for adjustable time. Extra secure against overflow.

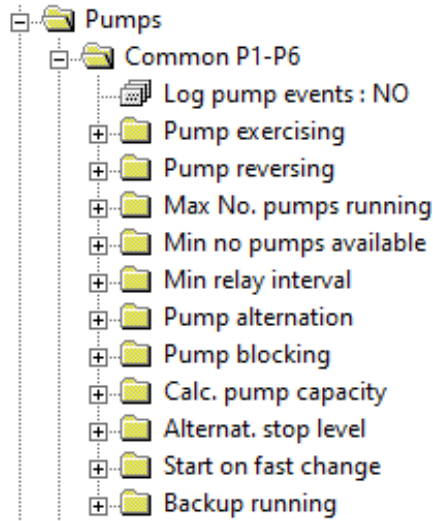

Figure 2.6: Aquaprog view of Pump settings

2.5.2 Pump 1-6 settings

Setting up the pumps and their alarms

Important parameters to configure for each pump:

- Type of pump control
- Running indication
- Start / stop level
- Pump alarms
- Pump valve (if used)
- Optional parameters: Pump curve

Type of pump control

- Pump disabled
If not using all pumps in BlueLinQ Pro, recommended is to let pumps with higher number to be disabled.
- ON / OFF control
A digital output starts the pump without any RS485 communication to VFD or soft starter
- VFD manual speed
Start a VFD which has predefined frequency
- VFD PID control
Start / stop pump with digital output and VFD controlled by 4-20 mA analog output from the controller
- VFD best efficiency point
Require RS485 communications to VFD

Select run indication

- Any discrete source
Output signal or digital input
- Output signal
No return signal from the pump, just activated output signal from the relay contact
- Motor current
Current transformers connected to an analog input

- Fieldbus RS485
RS485 communication to / from VFD or soft starter
- And current threshold (if applicable).
Select Power monitor if used

Start / Stop levels for each pump

Recommended is to have different start levels for the pumps and that no pump has the same start level as another. Same stop level for several or all pumps is fine.

Time settings

On/Off delays, maximum runtime

Pump curve

Recommended to enter the pump curve

Pump alarms

There are several pump alarms to setup. Each alarm is configurable to be A- or B-alarms. The first part, table 2-8 below, is to setup the types of alarm (A- or B), alarm delay and if the alarm shall trigger the crash log.

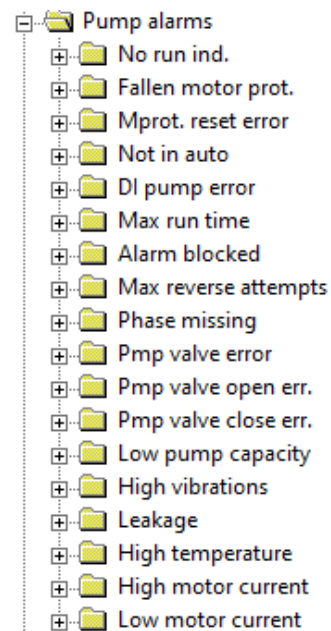

Figure 2.7: Aquaprolog view of pump alarms

Block pump on alarm

These alarms must be acknowledged on site or remotely to allow the pump to start again.

Hold pump on alarm

All the alarms here will block the pump when the alarm is active. When the criteria for the alarm have returned to normal state, the pump starts again automatically.

Best efficiency point

Best efficiency point is a function which require VFDs and RS485 communication to VFDs.

Pump valve

Time settings for individual valve for each pump.

Pump Tag name

Give the pump a name, max. 11 characters

Block pump on alarm

These alarms must be acknowledged on site or remotely to allow the pump to start again.

Hold pump on alarm

All the alarms here will block the pump when the alarm is active. When the criteria for the alarm have returned to normal state, the pump starts again automatically.

Best efficiency point

Best efficiency point is a function which require VFDs and RS485 communication to VFDs.

Pump valve

Time settings for individual valve for each pump.

Pump Tag name

Give the pump a name, maximum 11 characters

2.6 Set log settings and events

There are 32 configurable analog log channels on the EC 541. It is recommended to use the log channels in sequential order from channel 1, as having log channels disabled between active channels will cause unnecessary data traffic to the surveillance system.

The logs are kept in the controller for 31 days and the oldest will be deleted when the memory is full.

The settings are:

- Log signal
- Log function
- Log interval

There are 39 Log signals which can be logged. The Log functions can be set as follows:

- Closed
- Actual value
- Average value
- Min. value
- Max. value

Closed: No logging.

Actual value: A momentarily value will be stored at the log sequence.

Average value: An average value during the log interval will be stored.

Min. and max. value: The min or the max value in the interval will be stored.

The log interval can be set from 1 minute to 65535 minutes.

Table 2.6

Log signals
Level pit
Inflow pit
Outflow pit
Overflow level
Overflow flow
Outlet pressure
Motor current
Pump capacity
Power factor
Temperature motor
Temp. stator wiring L1
Temp. stator wiring L2
Temp. stator wiring L3

Table 2.6

Log signals (cont.)
Temp. upper bearing
Temp lower bearing
Vibration
Main voltage
Main frequency
Free choice AI
Free choice RTD
Power supply
Pulse channel 1-4
PID control output
Data register
Data register 2-compl
Set frequency

Table 2.6

Log signals (cont.)
Actual frequency
Motor power
Torque
Outflow meter
PCB temperature BlueLinQ Pro
BEP frequency
BEP efficiency
Mains power
Actual head
Secondary pit level
Pit level difference
Free choice AI

Events

Event list stores individual events such as pump starts / stops, alarms, alarm types and when the alarms occur and when it was acknowledged. The controller stores 4096 time-stamped events.

The event list is always active for alarms. To activate event list for pump starts / stops, **Settings > Common P1-P6 >**

Log pump events - Yes

2.7 Set up communications to surrounding units VFD, soft starters and energy meter

See installation guide how to connect the surrounding units. Note that all the surrounding units must have unique Modbus IDs and same communication parameters.

BlueLinQ Pro controller has BIAS-jumpers for high and low signals which by default are active in the controller. If any of the other units also have this BIAS feature, it can be necessary to take out the BIAS-jumpers from BlueLinQ Pro controller. Consult the manuals for all units connected to RS485 bus if there are other units using BIAS pull-up / down resistors.

2.8 Set up cleaner, mixer or drain pump (if used)

If using cleaner, mixer or drain pump, a corresponding digital output must be configured.

Cleaner:

The settings for cleaner are to be found:

Settings > Pump pit > Cleaning control

The cleaning can be done at pump start or at pump stop.

Running time in seconds.

Start counter interval is how many starts / stops before cleaning starts.

Mixer:

The settings for Mixer is to be found:

Settings > Pump pit > Mixer control

The mixer can be started after a certain number of regular pump starts or after a time interval. There is also a criterion to set the level to be within a certain span. The mixer run time must also to be set.

The mixer status is visibly on the main screen on BlueLinQ Pro.

Drain pump:

A drain pump requires a start float to be connected to a digital input which is configured with the start float drain pump option. The setting for drain pump is to be found:

Settings > Pump pit > Drain pump control

The Drain pump starts on a digital input configured as Start drain pump. Drain pump runs only on time settings, there is no stop float for the drain pump. A digital output must also be configured as Drain pump control.

3 Detailed descriptions of the functions

In this section we will explain more in depth how different functions work and how the controller calculates flows. Explanations will also be given for different input and output types.

Each chapter contains examples on how to configure functions in the controller and in some cases, where to find the settings when using Aquaprog.

3.1 Pump capacity calculation

This covers the importance of choosing the right scaled level sensor for the application, shape and size of the pump pit, pump curve and the parameters for each pump which must be set.

3.2 Overflow flow calculation

Here is explained the number of ways to calculate overflows and how it can be detected by the controller. Also lists the advantages and disadvantages of the different calculation methods used to detect overflows.

3.3 Pump alternation

Describes the different options, normal-, asymmetrical- and runtime alternation. The max number of pumps running is also explained here.

3.4 Pump reversing

Pump reversing is explained and what criteria are used by the controller to reverse the pumps.

3.5 Speed controlled pumps (VFD)

How to setup a speed-controlled pump and how the PID regulator works.

3.6 Best efficiency point

Best efficiency point is a function which require VFDs and RS485 communication to VFDs.

3.7 Crash log

The crash log is explained here, and how to read out the crash log from the controller.

3.8 Communication

Describes the communication ports and how to set up communication to external system.

3.9 Cross reference table

How to setup cross reference table is explained here.

3.1 Pump capacity calculation

In the BlueLinQ Pro controller there are some crucial parameters which have to be set for accurate calculation of in / outflow and pump capacity. We will describe each parameter in general terms later in this document. The parameters considered for pump capacity calculation in the controllers are:

- Level sensor
- Shape and size of the pump pit
- Pump curve
- Parameters under settings in Calculation of pump capacity
- Option: outlet pressure sensor

Level sensor:

There must be a level sensor or an accurate level measuring device (from now on referred as: level sensor) present in the system so the controller can track the level and changes in level in detail. The sensor shall be connected to an analog input signal, normally "Ain:1" which has the highest resolution. The analog input channel shall be scaled as the property of the sensor.

Note *The smaller span the level sensor has, the greater is the accuracy.*

Table 3.1: Accuracy of the level sensor to be expected

The resolution of a flow calculation, based on a 1,8 m diameter round pit -->	
Enter pit diameter in meters:	3,57
Area m ²	10,00982

Impact of the monitoring device technical capability												
Bit	Digits	Resolution depending on range using a 0 – 20 mA input:										Unit
		0 - 2 m in mm	0 - 2 m in litres	0 - 4 m in mm	0 - 4 m in litres	0 - 5 m in mm	0 - 5 m in litres	0 - 10 m in mm	0 - 10 m in litres	0 - 40 m in mm	0 - 40 m in litres	
10	1024	1,9531	19,550	3,9063	39,101	4,8828	48,876	9,766	97,752	39,0625	391,009	Many older PLC's EC531 (Ain 1) PCx (Ain 1)
12	4096	0,4883	4,888	0,9766	9,775	1,2207	12,219	2,4414	24,438	9,7656	97,752	
14	16384	0,1221	0,1221	0,2441	2,444	0,3052	3,055	0,6104	6,110	2,4414	24,438	
15	32768	0,0610	0,0610	0,1221	1,222	0,1526	1,527	0,3052	3,055	1,2207	12,219	
20	1048576	0,0019	0,0019	0,0038	0,038	0,0048	0,048	0,0095	0,095	0,0381	0,382	

Impact of the monitoring device technical capability												
Bit	Digits	Resolution depending on range using a 0 – 20 mA input:										Unit
		0 - 2 m in mm	0 - 2 m in litres	0 - 4 m in mm	0 - 4 m in litres	0 - 5 m in mm	0 - 5 m in litres	0 - 10 m in mm	0 - 10 m in litres	0 - 40 m in mm	0 - 40 m in litres	
10	1024	2,4414	24,438	4,8828	48,876	6,1035	61,095	12,207	122,207	48,8281	488,761	Many older PLC's EC531 (Ain 1) PCx (Ain 1)
12	4096	0,6104	6,110	1,2207	12,219	1,5259	15,274	3,052	30,548	12,2070	122,190	
14	16384	0,1526	1,527	0,3052	3,055	0,3815	3,818	0,763	7,637	3,0518	30,548	
15	32768	0,0763	0,764	0,1526	1,527	0,1907	1,909	0,381	3,818	1,5259	15,274	
20	1048576	0,0024	0,024	0,0048	0,048	0,0060	0,060	0,012	0,119	0,0477	0,477	

Shape and size of the pump pit shape

In the settings in BlueLinQ Pro controller where it is possible to set the shape of the pit. To get an accurate calculation at all levels, the pit shape must be defined as the calculation is different for different geometrical shapes. A shape that ends in a point is set as conical; if it ends as a wedge (2 parallel sides) it is set as rectangular shape, see figures below.

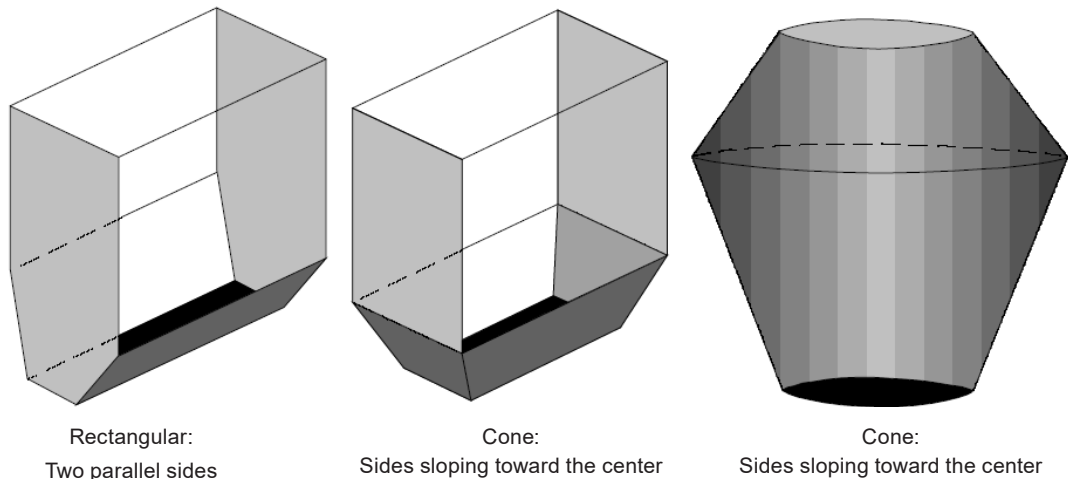

Figure 3.1: Pit shapes

Size of the pit

The continuous flow measurement is based on the fact that the BlueLinQ Pro can calculate the volume by measuring the level difference during a set calculation time. For this calculation to be accurate, it is essential that the area and the level should always be known. This can be achieved by setting the level and area for all levels where the pit changes shape, up to nine break points plus the area at zero point can be set. Those nine points shall be distributed along whole range of the pit up to the maximum fill level, with emphasis on areas where the pit shape changes form.

When the controller has the level sensor installed and it's correctly scaled, and the shape and size of the pit is known; the BlueLinQ Pro can easily calculate the volume. Any changes in the level are directly proportional to the amount of in / outflow and to the volume in the pit.

Pump curve

If you imagine a very deep pit or well, the out pumping from the pit is much easier when the level is very high. That's because the water pressure from the surface down to the pump "helps" the pump to lift the water. So in principle you can say that the pump lifts the water only from the surface and out – rather than from bottom and out. Depending on where the level is; the duty of the pump is shifting. Dependent on the motor and impeller type each pump will have a different Pump curve, see figure 3.2. From the pump curve three points within the range where the pit will operate can be taken, these three points are named as Hmax, Hmid, Hmin and stands for Total head max, Total head middle and Total head min. Check the Sulzer software ABSEL for the pump curve for your pump.

In BlueLinQ Pro controller (EC 541)

Under settings for each pump it is possible to set three points for the Pump curve and it's flow at the given points; Head (max); Head (mid) and Head (min) which correspond to Hmax, Hmid and Hmin. Total head can also be configured as a fixed value. If there is an Outlet pressure sensor in the system, then the Total head value is replaced in the calculation with the value from the outlet pressure sensor as Actual static head.

Typical the mid value is the best BEP and recommended operating range define Hmax and Hmin.

Hmax: (at pump outlet to pit outlet); is the highest lifting point and lowest level in the pit. At this point the pump has hardest load and is least efficient.

Hmin: (the highest point the surface of the level can reach; to the level of overflow etc.); is the highest level the pit can reach and lowest lifting point for the actual system and most efficient pumping.

Hmid: is a value somewhere in between Hmax and Hmin.

If sensor is mounted according to figure 3.3 below in example 1 where the pit bottom is 0.4 m below pump outlet, set parameter **Total head zero level = 18 + 0.4 = 18.4 m.**

Type in pump curve parameters in BlueLinQ Pro:

In the menu of BlueLinQ Pro:

Settings > Pump X (X = Pump 1–6) > Pump curve (QH)

- Point 1 head (max) = X.XX m (ft.) There XX is manually replaced with new value
- Point 1 flow (min) = X.X l/s (gal./min)
- Point 2 head (mid) = X.XX m (ft.)
- Point 2 flow (mid) = X.X l/s (gal./min)
- Point 3 head (min) = X.XX m (ft.)
- Point 3 flow (min) = X.X l/s (gal./min)
- Total head = X.XX m (ft.)

Example 1

A pit where the pump(s) has the lifting height of 18 meter from the pump outlet to pit's outlet. Therefore the Hmax is 18 meters. We have also an overflow outlet 5 meters from the pump(s) outlet where the overflow sensor is placed. The level can never be higher than 5 meters. Hmin is then 18 – 5 = 13 meter and Hmid is 15.5 meter, see figure 3.2 below.

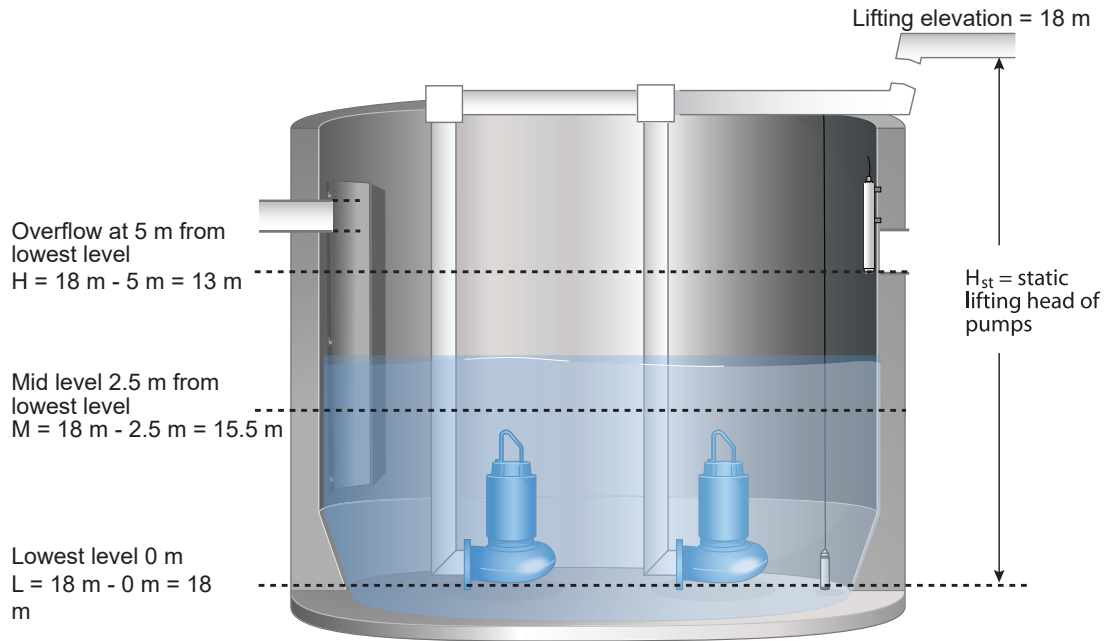

Figure 3.2: Explanation of H_{max} , H_{mid} and H_{min}

From pump curve, we can find the corresponding flow rate for each of; H_{max} , H_{mid} and H_{min} .

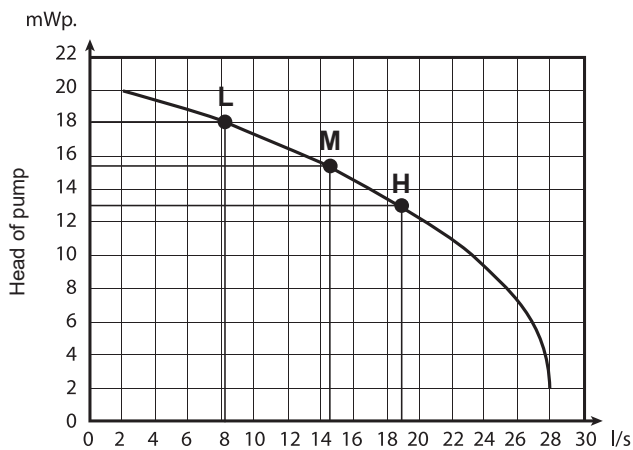

Figure 3.3: H_{max} , H_{mid} and H_{min} in the chart

- (L) Point 1 H_{max} total head 18.0 m (ft.)
Point 1 Flow 8.2 l/s (GPM)
- (M) Point 2 H_{mid} total head 15.5 m (ft.)
Point 2 Flow 14.4 l/s (GPM)
- (H) Point 3 H_{min} total head 13.0 m (ft.)
Point 3 Flow 19.0 l/s (GPM)

Actual static head

If using an analog input sensor allocated as Outlet pressure, on the outgoing mains the value of Total head is replaced with value from the sensor in outlet and pump capacity calculations. Actual static head makes the calculation much more accurate than a fixed value for Total head in the settings for each pump

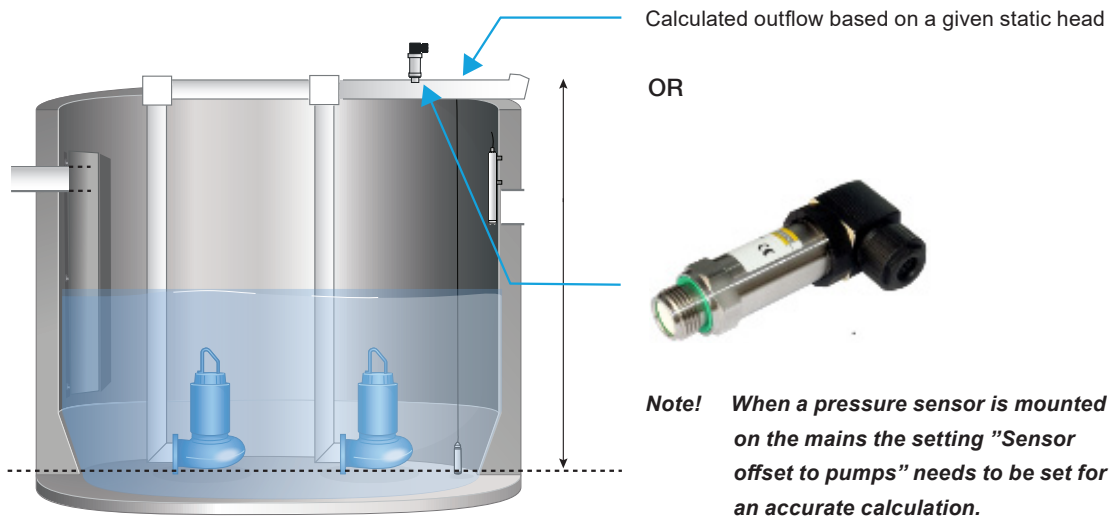

Figure 3.4: Actual static head explained

A pump is almost always used in a system of pipelines and valves. These give losses that the pump must overcome for a specific flow. The outlet pressure sensor gives the sum of the dynamic height and pipeline system losses at a specific flow (total head). It could be assumed that if two pumps of the same type are running in parallel then the outflow would increase by two, however sometimes due to the increase in back pressure the outflow will increase by less than this. This is because the pipeline losses increase with increased flow and higher back pressure thus the total lift height. If you do not compensate for this, the calculation of the output flow and pumped volume will be less accurate in the case of several pumps running. This is especially true when we have large pressure losses in the pipes in relation to the static height. This can happen, for example, when several pump stations are working in the same pipe system or if the pipes are partially blocked or if air entrapment occurs. An outlet pressure sensor considers all this.

As in the general description of the pump curve above, the back pressure is dependent on the level in the pit, but also on the flow rate in the pipes, number of pumps running and the outlet pressure. We have two ways to handle this; by Flow compensation and or use an Outlet pressure sensor.

Flow compensation has fixed calculation factors depending on the number of pumps running which is multiplied with the pump capacity for each pump but does not consider the level, flow rate and outlet mains-pressure.

Outlet pressure sensor considers the level, pressure on the outlet, the number of pumps running, pump capacities and pipe losses.

Therefore, with an outlet pressure sensor the calculation is much more accurate compared to using only the Flow compensation and a fixed value for static head.

Calculations

Inflow

If the controller knows the shape and size of the pit and together with a level sensor; the unit will at all times know the momentary volume of the pit and its inflow.

Pump capacity

A pump capacity calculation is performed every time the pump starts alone with no other pump running. If two pumps are running, the BlueLinQ Pro Controller will not perform any new calculation and will use the existing nominal pump capacity for the outflow calculation.

Important parameters to perform automatic calculations of pump capacity

All the important parameters for pump capacity calculation are to be found in the menu of BlueLinQ Pro Controller under:

Settings > Pumps > Common P1-P6 > Calc. pump capacity

- **Calculation ON / OFF:** must be ON (default OFF)
- **Min. level for calculation:** default 0.30 meter
- **Start delay:** default 10 sec.

- **Calculation time:** default 5 sec.
- **Stop delay:** default 5 sec.
- **Max. level for calculation:** default 3.00 meter

Note: *It may be necessary to adjust above parameters for accurate measurement of the capacity.*

Pump capacity calculation rules

- Only one pump is allowed to run during the whole sequence, otherwise no new calculations will start.
- The level must be over “Min level for calculation” during the whole calculation sequence .
- The level must be under “Max level for calculation” during the whole calculation sequence.
- The level after calculation must be lower than when the calculation started.
- The Calculation delay time must be long enough for the pump to reach full speed and for the water to reach full velocity in the pipes.
- All the times in Calculation delay + Calculation time + Stop delay must be in one and the same. pump sequence

When one pump starts alone

- The actual indicated inflow value is frozen when the pump starts and is temporarily stored in BlueLinQ Pro.
- The outflow is now ramped up for a configurable time frame set in settings for “Start delay”.
- When the pump is running at full speed and the water has full velocity in the pipes after the “Start delay”, the pump capacity is calculated over the time defined in the “Calculation time” setting.
- After the “Calculation time”, there is a “Stop delay” and when this time has passed, the inflow value is updated again.
- The BlueLinQ Pro does this calculation five times for each pump, the two most divergent results are removed and an average of the three remaining results is taken to give the new pump capacity value.

Example of calculation cycle:

1. No pump is running, level increasing due to inflow that is then calculated based on the area/level and time settings.
2. Start level reached.
3. Current inflow stored.
4. Time delay before pump capacity measurement, this to enable the flow to pick up speed depending on size of pit, pump, head and collection network design.
5. Measure speed of level reduction during a preset time to a pump capacity value is now obtained.
6. This capacity value is now adjusted to the pump curve (if entered).
7. Release the inflow calculation.
8. The inflow is now a function of the pump capacity and entered pump curve.
9. If yet a pump starts the outflow and inflow is then also adjusted according to the system curve.
10. If a pump is running and there is a stable level reading, this would indicate that the inflow matches the outflow.
11. If the level increases, it indicates that the inflow is higher than the pump capacity and the calculation is rejected.

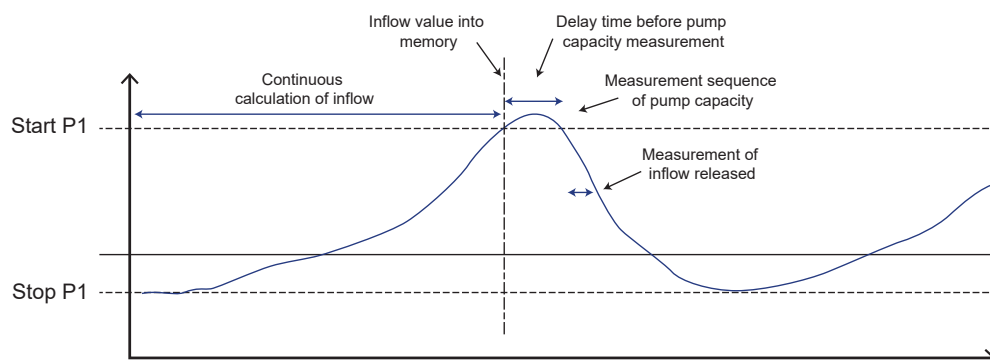

Figure 3.5: Pump calculation explained

Increased calculation accuracy

To improve the calculation accuracy and alarm handling, especially with varying start levels we recommend that the pump curves are entered. For a more accurate outflow calculation, the use of an outlet pressure sensor is recommended in the system. In this case the BlueLinQ Pro will recalculate and adjust the outflow calculation based on the momentary level.

Presentation of the pump capacity calculation

The pump capacity is presented as Pump capacity and Last sample value in BlueLinQ Pro Controller

Pump capacity

The nominal pump capacity is calculated from five readings of a single point on the "Pump curve". From these five values the two most divergent are removed and the average of the three remaining give the pump capacity.

Last pump capacity:

As it sounds, the last calculation, unfiltered and without compensation for Pump curve and it is just a raw value. Five of the "Last pump capacity" -values will create a new Pump capacity-value after all other parameters which are involved are set as described above.

In order for the BlueLinQ Pro to change the calculated Pump capacity (nominal-) value, there has to be five starts and stops for each pump and that pump must have been running alone those times.

Outflow

The internal outflow calculations are closely linked to the pump capacity calculation. When the pump starts and the running indicator is on, the BlueLinQ Pro Controller calculates the outflow by multiplying run time with the capacity of the pump(s). The calculation will also take into account the Pump curve, Outlet pressure and number of pumps running. If there is an analog input assigned as Outlet pressure sensor in the system, the Total head-parameter in the calculation is replaced with the value from the outlet pressure sensor.

If there is an analog input assigned as Outflow meter, BlueLinQ Pro Controller will ignore internal calculation of the outflow and only store the value from outflow meter. Neither the pump curve nor outlet pressure is in the value of outflow when using an Outflow meter

Example 2

How to read out the expected pump capacity based on the mains pressure and actual basin level.

The figure below gives an estimated pump flow as at new conditions of approximately 26 l/s.

Estimated theoretical pump capacity at start level

Bar → m H₂O = 10.1972

Mains pressure = 1.95 bar → 19.89 m

Static head = 3 m

Start level = 0.5 m

Geodetic head = 0.5 m

Total head at start level =

$19.89 + (3 - 0,5) = 22.39$ m

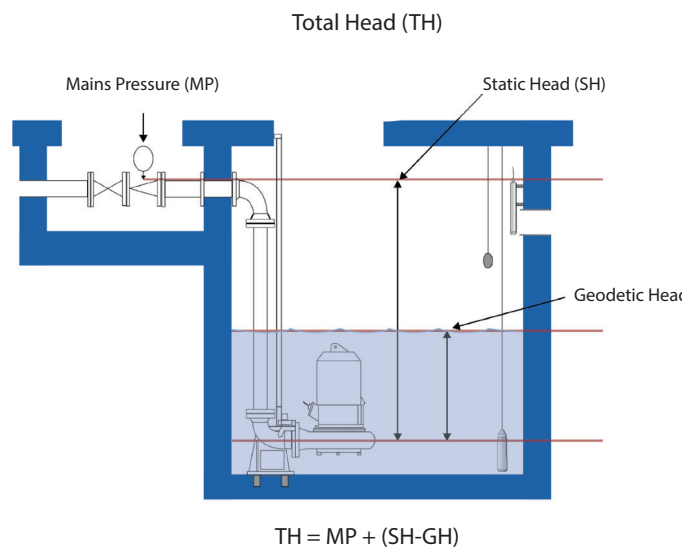

Figure 3.6: Relation between pump curve and the pit

In practice

A fictional station with two Sulzer pumps, XFP 150G CB1 50 Hz and a BlueLinQ Pro Controller. The data sheet for the pump:

SULZER

XFP150G CB1 50HZ

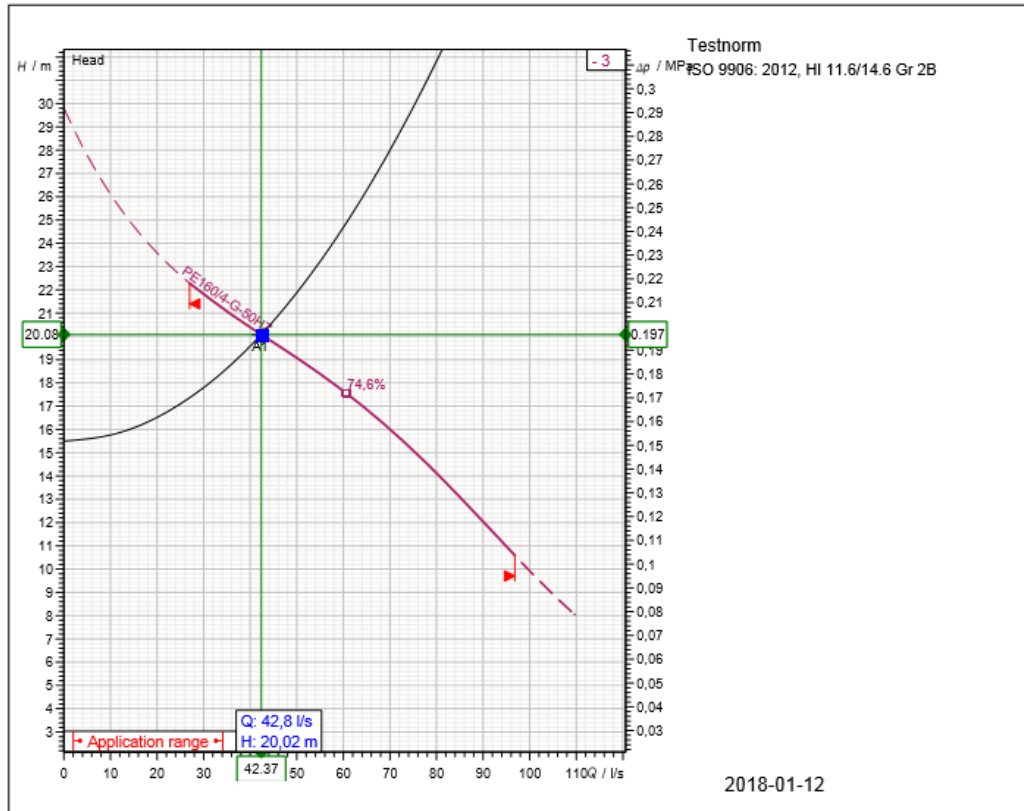

Operating data specification			
Flow	42,4 l/s	Head	20,1 m
Efficiency	71,2 %	Shaft power	11,7 kW
NPSH	1,97 m	Fluid	Water
Temperature	20 °C	Nature of system	Single head pump
No. of pumps	1		
Pump data			
Type	XFP150G CB1 50HZ	Make	SULZER
Series	XFP PE1-PE3	Impeller	Contrablock Plus impeller, 1 vane
N° of vanes	1	Impeller size	275 mm
Free passage	100 mm	Suction flange	DN150
Discharge flange	DN150	Type of installation	Not chosen
Moment of inertia	0,104 kg m ²		
Motor data			
Rated voltage	400 V	Frequency	50 Hz
Rated power P2	16 kW	Nominal Speed	1470 1/min
Number of poles	4	Efficiency	92,2 %
Power factor	0,758	Rated current	33,1 A
Starting current	317 A	Rated torque	104 Nm
Starting torque	440 Nm	Degree of protection	IP 68
Insulation class	H	No. starts per hour	15

Sulzer reserves the right to change any data and dimensions without prior notice and can not be held responsible for the use of information contained in this software.

Spaix® 4, Version 4.3.4 - 2017/03/02 (Build 578)
Data version Mar-2017

Figure 3.7: Example of data sheet

Data from graph

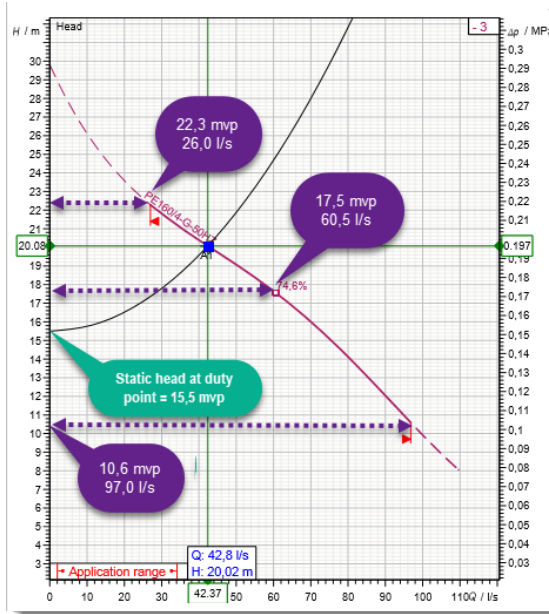

Figure 3.8: Example from a data sheet

Settings / Pump 1 / QH curve (pump curve)

Pump curve (QH)

- 1.34 Point 1 head (max) = 0.00 m
- 1.34 Point 1 flow (min) = 0.0 l/s
- 1.34 Point 2 head (mid) = 0.00 m
- 1.34 Point 2 flow (mid) = 0.0 l/s
- 1.34 Point 3 head (min) = 0.00 m
- 1.34 Point 3 flow (max) = 0.0 l/s
- 1.34 Total head = 0.00 m
- 1.34 Pump curve Q-H exponent = 0.0000

Note: If not using an outlet pressure sensor – a value for Total head must be given; in this case: 20.1 m

<p>Operating data specification</p> <p>Flow 42.4 l/s</p> <p>Efficiency 71.2 %</p> <p>NPSH 1.97 m</p> <p>Temperature 20 °C</p> <p>No. of pumps 1</p>		<p>Head 20.1 m</p> <p>Shaft power 11.7 kW</p> <p>Fluid Water</p> <p>Nature of system Single head pump</p>	
--	--	---	--

Figure 3.9: Example from a data sheet

Other parameters needed for the flow calculation set-up:

Settings / Station flow / Pit area

Station Flow

- Meas. Parameters
- Pit Area
 - Level 0 = 0.00 m
 - Area 0 = 10.0 m2
 - Level 1 = 4.70 m
 - Area 1 = 10.0 m2
 - Level 2 = 2.00 m
 - Area 2 = 0.0 m2
 - Level 3 = 0.00 m
 - Area 3 = 0.0 m2
 - Level 4 = 0.00 m
 - Area 4 = 0.0 m2
 - Level 5 = 0.00 m
 - Area 5 = 0.0 m2
 - Level 6 = 0.00 m
 - Area 6 = 0.0 m2
 - Level 7 = 0.00 m
 - Area 7 = 0.0 m2
 - Level 8 = 0.00 m
 - Area 8 = 0.0 m2
 - Level 9 = 0.00 m
 - Area 9 = 0.0 m2

Pit area settings:

Up to nine different areas can be defined for different levels in the basin

STATION FLOW:PIT AREA

Level 0	0.00 m >
Area 0	10.00 m2 >
Level 1	0.50 m >
Area 1	10.00 m2 >
Level 2	1.00 m >
Area 2	10.00 m2 >

Figure 3.10: Examples from Aquaprog and menus

Station flow settings

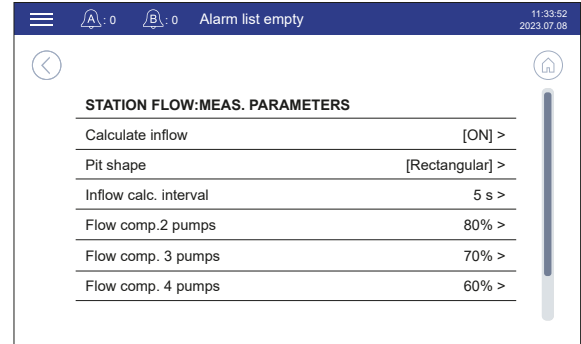
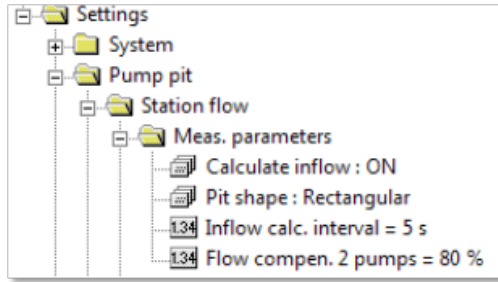
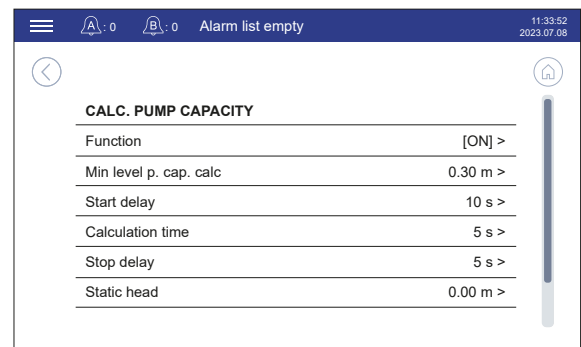
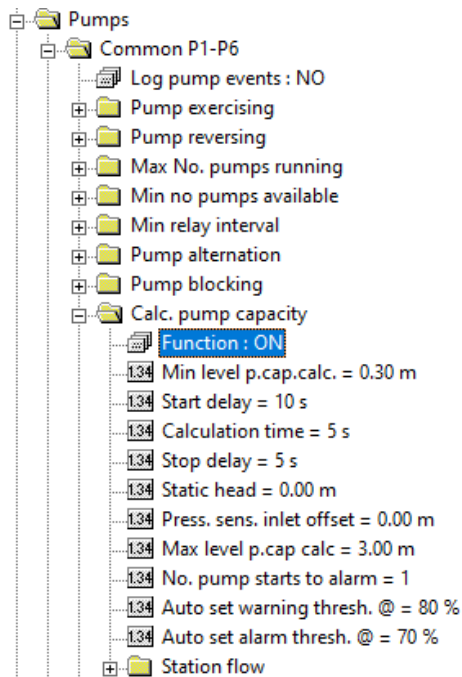

Figure 3.11 Examples from Aquaprog and menus

Settings of criteria for calculation of pump capacity



The level settings will set boundaries for the possible levels in the basin where calculations can be conducted.

The start delay time is a crucial setting, verify that the flow rate in the pipe has reached full velocity before the calculation is executed.

Figure 3.12 Examples from Aquaprog and menus

Example from a run sequence based on a described set data in the BlueLinQ Pro shown in AquaWeb.

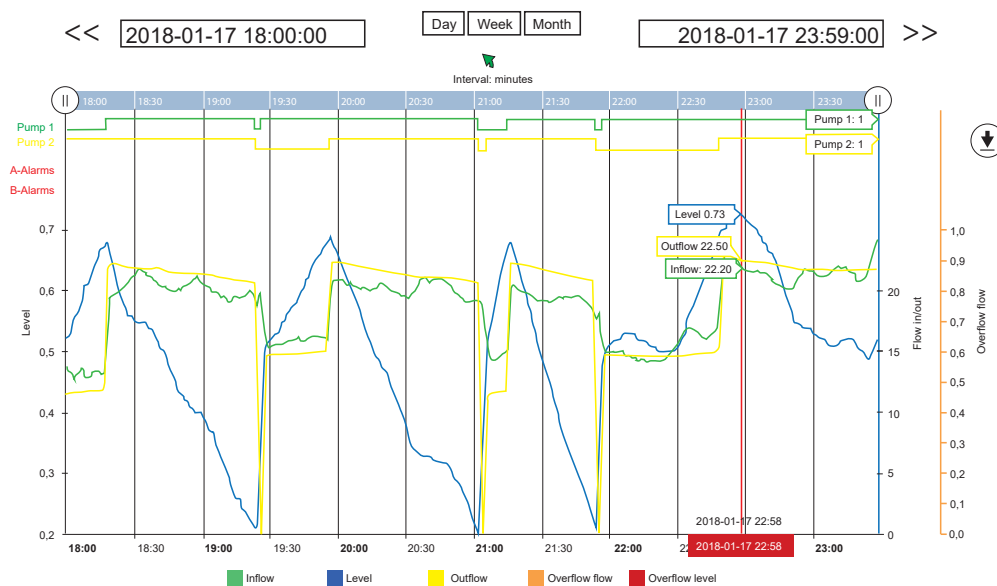

Figure 3.13: Example of AquaWeb chart

If the start delay time is set too short, the calculated capacity is often too low.

If the inflow value "jumps" at every pump sequence this is normally because of:

- Wrongly set calculation parameters
- Back flush valve not working correctly

3.2 Overflow flow calculation

There are three main methods that can be used to measure and calculate overflow rate:

1. Use a conventional flow meter.

Advantage: In most cases for standard PLC-systems this will increase the accuracy on the measurement.

Drawbacks: Expensive. Also during normal operating conditions, sensors which only measure overflow, can accumulate dirt which will affect their readings; therefore the sensor must be cleaned regularly to ensure accurate measurements.

2. Use the same sensor that is used for the level measurement in the pit remove and start the flow measurement on an analog set point.

Advantage: The investment cost is low, and the sensor will not need regular cleaning.

Drawbacks: The system must have very good resolution on the input to be able to measure the overflow correctly and a very accurate 0-point otherwise the measurement will be inaccurate.

3. Use the same level sensor that is used for the level measuring in the pit and use a level switch to start the overflow measurement.

Advantage: The Investment cost is low and the sensor does not require regular cleaning. The accuracy of the 0-point does not affect the measurement as the switch is used as the 0-point.

Drawbacks: The analog input needs to have very good resolution to be able to measure the signal. The BlueLinQ Pro controller does not have this problem, for example a sensor with the range of 10 meters the BlueLinQ Pro controller has the resolution of < 0.7 mm.

Note: The third method is the preferred one to be used in the BlueLinQ Pro.

A digital overflow switch, like Sulzer MD 131 connected to a digital input indicates if an overflow is occurring independent of what the level signal shows. The BlueLinQ Pro locks this actual level and starts calculating the overflow level / flow from this value.

This means that the level is measured with a very high accuracy with an accurate 0- point. If an exact flow measurement is needed a weir or channel should be used.

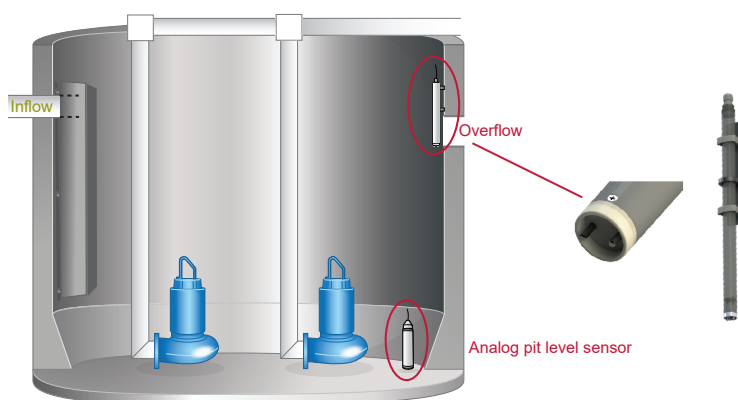

Figure 3.14: Pump pit with level and overflow sensor

The BlueLinQ Pro program has all the functions available for calculating flow in weirs and channels. Number of overflows, overflow time and overflow level and the flow are logged.

The levels sensor is used as the actual level signal, when the switch is activated, it sets the 0- point for the flow measurement. If no level switch is connected to the BlueLinQ Pro the 0- point for the overflow can be set in:

Settings > Pump pit > Overflow > High level limit

Overflow / Overflow detect “manually”. Overflow will be registered when the level exceeds pre-set overflow level on the usual level sensor.

Note: *This set point has no function if a digital input (overflow switch) is set for overflow indication in the pump pit.*

A delay can be set to prevent disturbances or waves that could trigger the switch. After this delay the flow measurement starts and the time of the overflow is recorded. A counter keeps track of how many times the pit has overflowed. The overflow time is only triggered when the level is higher than the stored (set) 0- point. If a float sensor is used for a pump pit, which has no level sensor, the overflow time counts all the time the float is active.

Once the float goes back to normal, the overflow alarm will cease after the configured stop delay duration to avoid errors in the counter and to compensate for the start delay.

Note: *Overflow alarm and counter is only detected if alarm is enabled.*

How to calculate overflows by using constants and exponents

In Settings > Pump pit > Overflow

You can type in the constant and exponents manually.

There are two different exponents and two constants which can be set in BlueLinQ Pro which are dependent on manufactures and nature of the weirs. Those constants shall normally be provided by the manufactures. If you don't have the e2 and c2 values, you can put e2 and c2 to 0 (zero), only use the left side of the equation. For the basic weir types, the c2 constant is set to 0 (zero).

Overflow= $he_1 c_1 + he_2 c_2$ [m³/s]

Type of weir	Exponent	Constant
Thompson 30°	2.5	0.373
Thompson 45°	2.5	0.569
Thompson 60°	2.5	0.789
Thompson 90°	2.5	1.368
Straight weir 1 m	1.5	1.76

For other width on straight weirs, multiply the constant with the width in meters. Ex. $c = b * 1.76$ (b in meters)

Note: *If "Locked on inflow" is chosen, it assumes overflow will be the last calculation of inflow in the pit minus the capacity of the pumps which are running.*

3.3 Pump alternation

The BlueLinQ Pro has three different methods in order to alternate pumps.

1. Normal alternation

Pumps are started alternately according to a rotating schedule. The pump that started first in the previous pump cycle, will start last in the next cycle. In this way the running time is divided equally between alternating pumps. Pumps that are not set for alternation, start and stop at their own defined levels.

One can choose that alternation occurs at each pump stop or when all pumps are stopped.

It is preferred that alternation at each pump stop is used when the inflow is so high that the pumps don't have enough capacity to fully empty the pit. This prevents the situation where one pump is running continuously.

It is preferred that alternation at all pumps stopped is used when the inflow is such that the pumps have enough capacity to fully empty the pit.

2. Asymmetrical alternation

It is possible to set a pump to be the main pump and let the other pump run less in time. This is to save one of the pump so that the maintenance does not occur simultaneously on both pumps, which avoids a total stop for the entire station.

P1 run time ratio = 70% - means that the pump 1 will run 70% of the time.

3. Runtime alternation

The pumps can also be alternated based on continuous runtime. At exceeded maximum run time the pump will stop and an alternative pump will be started. The pump will only stop if the other pump is available and ready to run.

Max. number of pumps running

If the piping system cannot take the pressure when two pumps are running there is a possibility to set the max. number of pump that is allowed to run at the same time to one. It could also be used when there is a limit for the power load in the station.

If max. number of pump is set to one the system will not allow the other pump to start. A pump is running when the relay of the pump is activated or there is a run confirmation from the pump.

If max number of pump is running and the run confirmation is lost or some other errors that block the pump occur. The following will happen.

- Alarm for the error will be indicated.
- The faulty pump stops.
- If alternation is active, after a delay the other pump will be start.
- If alternation is not active the other pump will start at the next start level.

3.4 Pump reversing

The reverse pumps may be triggered on

- Digital input "Pump fail"
- Tripped motor-protection
- High motor current
- Low capacity
- After number of pump starts

In Settings > Pumps > Common P1-P6 > Pump reversing

These are the events that can trigger pump reversing

1. Reverse on Pump fail
Reverse cycle start when digital input signal Pump fail goes active.
The signal must go back to inactive state before the pump start reversing, if not reversing cycle is aborted.
2. Reverse on Fallen motor-protector
Reverse cycle start when the digital input signal Motor protector goes active. Motor protector will be reset before the pump start reversing. You must enable auto reset motor protector function for the pump. Set the cold down time and pulse time in the auto reset menu. If the motor protector reset fails reversing cycle is aborted.
3. Reverse on High current
Reverse cycle start when alarm for High motor current is activated. For this function to work you need to enable the alarm in the pump alarm menu. Use the alarm delay time to delay the start of reversing (don't trigger on pump start current).
4. Reverse on Low pump capacity
Reverse cycle start when alarm for Low pump capacity is activated. For this function to work you need to enable the alarm in the pump alarms menu. After reversing the function is disabled until at least 10 new pump capacity calculations have been done.
5. Reverse on After number of pump starts
Counter for cyclic reversing of pump.

Other settings regarding pump reversing:

Settings > Pumps > Common P1-P6 > Pump reversing

- Set [Reversing pump x] to [Yes].
- Set [Start rev. delay time]. The time to hold the pump in off position before the start of pump reversing
- Set [Rev. run time]. The reversing run time.

- Set [**Max no. attempts**] After the reversing the pump will start again.
- Set [**Max attempts reset time**]
- Set [**Stop second pump**] to [**Yes**] if you want the other pumps to stop and stay blocked when reversing cycle run.
- Set [**Pump relay when rev.**]

If the pump fails again, a new reversing cycle will begin. Here you set max number of attempts. The reversing has succeeded if the pump has been running for the same time as the [**Start rev. delay time**] without any pump error. If successful the attempt counter is reset to 0.

If the attempts counter reach max number of attempts, an alarm will be generated and all further reversing stopped until motor protector alarm or pump fail alarm have been reset manually.

If [**Pump relay when rev**] is set to [**ON**], the pump relay will be activated 1 sec after the reversing re-ly and will be set to OFF 1 sec before the reversing relay goes off. Here pump relay is used to control the pump (**ON / OFF**) and reversing relay is used to shift two phases before reversing.

If [Pump rel. when rev] is set to [**OFF**] only the reversing relay is activated during reversing. Pump relay is always off.

3.5 Speed controlled pumps (VFD)

The BlueLinQ Pro has two Modbus RS485 interface which can communicate with VFDs. It is highly recommended to use this feature when there are VFDs in the system.

VFD pumps are mainly controlled by start / stop level and the digital outputs like fixed speed pumps. The best way to control the VFDs is via the RS485 bus which can control the speed, read the information from the pumps such as currents, speeds and loads. It is also possible to use the analog output signals to control the speed in VFD unit(s) which drive the pumps. Normal start and stop levels are used to start and stop the VFD pump(s). The built-in PID controller is used according to the con-stant level control method and outputs frequency set points to the VFD. The PID controller will raise the frequency when the water level tends to rise above the set level and lower the frequency when the water level tends to fall below the set level. In some cases, the control logic will override the output signal from the PID controller.

At start level the pump will always start at max frequency. Output signal is kept at max freq. until the set level is reached. If calculation of pump capacity is enabled the pump will run at max frequency, until the calculation is completed. If the pump is running at min frequency for an adjustable time you can set a force speed for pumping out the pit. The pump will go on force speed until stop level is reached (or set level).

If the pump is exercised, the pump will run on max frequency. When reversing the pump, the specified reverse speed value will be used (50% default). In high tariff pre pump down mode the pump will run on the same force speed as specified for min freq. timeout.

If there is more than one pump connected to VFD, the pumps will be synchronized. The output signals will always be the same if the scaling is the same. The VFD is responsible for speeding up and down the pump. BlueLinQ Pro controller doesn't handle ramp times. The min and max frequency for the pump normally is set on the VFD. The PID controller also has adjustable min and max value for the output signal that can be used.

There is a possibility to run VFD pumps with two different set points connected to, day and night settings. PID operator settings are found under:

Settings > PID controller

Setup BlueLinQ Pro controller for VFD pump(s)

In Settings > Pump x menu:

Set Type of pump to [VFD manual speed or VFD PID control or VFD best efficiently point] (see section 2.4 for explanations of different types). If a second VFD pump is used. Set the same type for that one.

In Settings > Pump x menu:

Set the start and stop level for the pump the start level should be higher than the set level on the PID controller. The stop level should be lower than the set level.

In Settings > Analog outputs > Analog output 1 menu:

Set output function to [PID controller].

The same for Analog output 2, if a second VFD pump is used, the output should be connected to the frequency input on the VFD

In Settings > Digital outputs;

Set output function [Pump relay] as for fixed pumps. The output should be connected to the "Run input" on the VFD.

In the Settings > PID regulator menu:

- External set point (On/Off)
If using external input for set point, specify the analogue input here or set to OFF.
- AI Module
Select AI module 1-9 if used
- Setpoint tracking (Yes / No)
Rarely used. Is that the internal setpoint follows the external that comes via an analogue input. When you then switch to the internal setpoint, it has the same starting value as the external (AI) had before wrapping. Is to prevent the setpoint from jumping to when switching between external and internal setpoint.
- Setpoint when start:
Last: last value, Setup start: start value, Extern: value according to specified input.
- Max set point and Min set point
Levels for the set point and a start set point. Here you can set max and min values to corresponding levels for the output signal (min / max freq). Value at Min level = 4 mA and Max level = 20 mA. What frequencies these correspond to depends on the settings in the VFD.
- Setpoint
Set point value
- Setpoint high tariff
The set point value at high tariff
- Start setpoint
Behavior when the controller is powered on
- Output state when start
Last state, Auto, Manual or Internally blocked. Only valid when the controller is powered up.
- Output when blocked
Freeze output or Setup block signal Behavior when the PID gets blocked
- Block output (%)
Percentage of output signal when blocked
- Max output change
The change speed of the output signal (%/s)
- Max output
Normally 100% (20mA)
- Min Output
Normally 0% (4mA)
- Start output (%)
Which output regulator should have after booting (e.g. after network interruption)
- Direct / Reverse effect
Direct: The pumps start at full speed and decrease in speed as the level decreases Reverse: The pumps start at low speed and increase in speed as the level decreases.
- P-band
Amplifying factor
- I-time (s)
Integration time
- D-time (s)
Derivation time
- Zero dev. output (%)

- Is which output regulator should when the Setpoint = actual value thus at zero-deviation normally not used (normally 0%). Mostly used for clean P regulation.
- Calc. pump cap. At max speed (Yes/No)
- Min speed (%)
Here you set the minimum pump speed
- Locked speed pumping out (%)
The speed of the pump when it has run for an adjustable time at lower speed and starts to pump out.
- Lock speed delay
If the pump is running at min frequency for an adjustable time you can set a force (lock) speed for pumping out the pit. If locked speed delay = 0 the function is disabled.

3.6 Best efficiency point pump control

Offers many advantages:

- Reduced energy cost
- Extended bearing life
- Longer maintenance intervals (slower degradation)

Instead of trimming impeller, a variable frequency drive is used to optimize performance. This is possible whenever actual operating point is on the right side of BEP in pump curve, the normal for most wastewater pump installations.

BlueLinQ Pro connects to most variable frequency drives with the RS485 Fieldbus for monitoring and control. With just a level sensor and a supported VFD attached, the pump will always run at the BEP.

By also setting up the pit area, required for pump capacity calculation, comparable data in engineering units opens for benchmarking between pump stations, and easy finding the worst behaviors and best pay-off of new improvements.

The BlueLinQ Pro is continuously searching for the best efficiency point to get out as many m3 water / kWh as possible.

Calculation is done every time a pump starts alone by calculating a new efficiency index and a new BEP in kWh/m3 from a snapshot of energy consumption and change in pit volume short after the set motor RPM is reached. Some conditions require full speed of the pumps. Following reasons can be configured in BlueLinQ Pro controller for full pump speed.

- Start at full speed every n (adjustable number-) of pump start for a preset time frame to flush pipes.
- At high inflow, if both pumps are running for a preset time.
- High level alarm

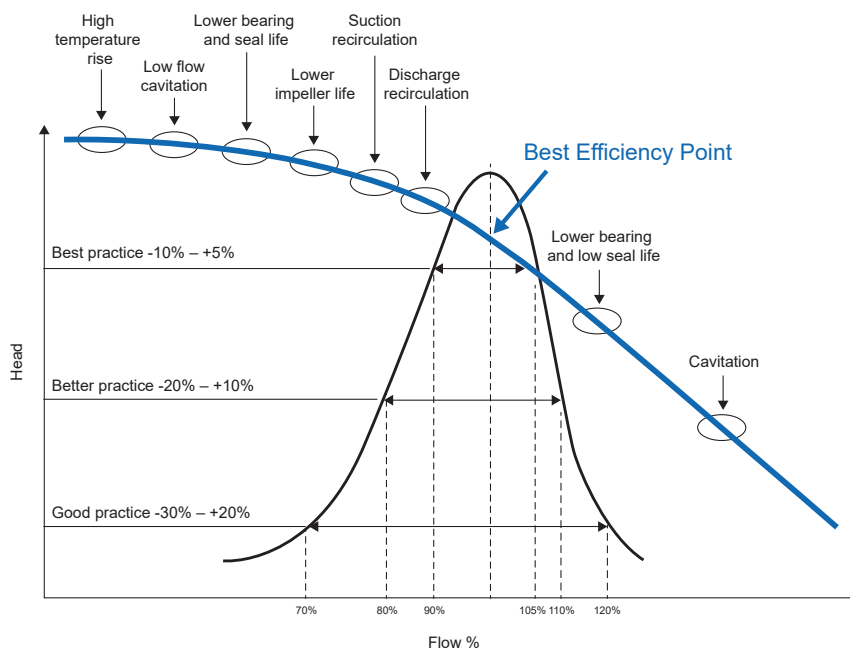

Figure 3.15: Example of a curve in BEP

3.7 Crash log

In case of any type of a severe equipment or station problem, a crash log can provide useful and detailed information in four different crash logs. This can provide us with the data needed to reveal problems not otherwise detectable in a normal 1-minute average log. Every alarm which can be configured in the controller, can also generate a crash log. The shortest interval for the ordinary logs is 1 min (60 sec.). The crash log has the interval of 1 second (not adjustable). When crash log initiates, the controller store values 6 minutes before the event and 2 minutes after the event which has triggered the crash log. The controller keeps the past four crash logs in memory and each crash block contains data for 480 seconds of 138 fixed log parameters. The four crash blocks are stored with a time stamp, ID no and alarm no for the trigger alarm.

The BlueLinQ Pro controller is continuously saving raw analog input data every second.

The data and up to four crash blocks are stored and can be retrieved to a PC with the AquaProg tool.

3.8 Communication

There are six ports for communication. One USB for updating firmware and uploading/downloading configuration, and one RS232 which can be connected to a modem or a protocol converter. One Ethernet and two ports for RS485 to surrounding units like VFD, soft starters and energy meters or to a SCADA. The protocols are Modbus RTU or Modbus TCP. If other protocols are needed to an external SCADA system, it could be available if there is an external converter from Modbus to the requested protocol. One CAN-bus to BlueLinQ Pro expansion units.

Modem port (terminals 18 – 22)

This port is designed for Sulzer 4G (CA 524 modem) communication and has protocol Modbus RTU or Modbus TCP. This port also supports CA 521 to send text messages. CA 524 can also send text messages (SMS).

Default this port has Modbus RTU,

Baud rate: 115200 Parity: none
Handshake: off Protocol ID: 1
Message time out: 2 s Optional: station name.

On this port it is possible to change the properties; baud rate (300 – 115200), protocol ID (1 – 255) and station ID (1 – 65535), parity (none, odd, even) and handshake (on / off) as well.

Note: *The PIN code on the SIM card can be deleted with a cell phone.*

GPRS modem

Sulzer modems CA 521 – CA 524 is based on internal TCP / IP stack in Cinterion (former Siemens) GSM / GPRS modules. All data access is via the Hayes commands are defined by Cinterion. Default is that the pump controller connects to the TCP server in Sulzer ABS AquaWeb system. Set PIN code if SIM card is equipped with one (deleted on AquaWeb SIM cards).

The heartbeat interval is set at 10 mins (default) but can be adjusted (lower interval may lead to extra costs). Server TCP port; must be the same as in GPRS server (default 2000 for AquaWeb). Servers IP address: the public / global IP (normally in fire wall / router) address to the GPRS / 3G server must be a static IP address. APN is provided by SIM card supplier. GPRS APN part 1 and GPRS part 2. If APN string is long, it can be divided between the two parts. (Default is AquaWeb APN). SMS fallback: 0046708728550 for AquaWeb only.

Settings under Communication – Modem port– Modem type in the BlueLinQ Pro should be set too.

Set GPRS username and password if demanded from subscription provider. GPRS event log and heart beat operator scan for error search only. Default 10 minute.

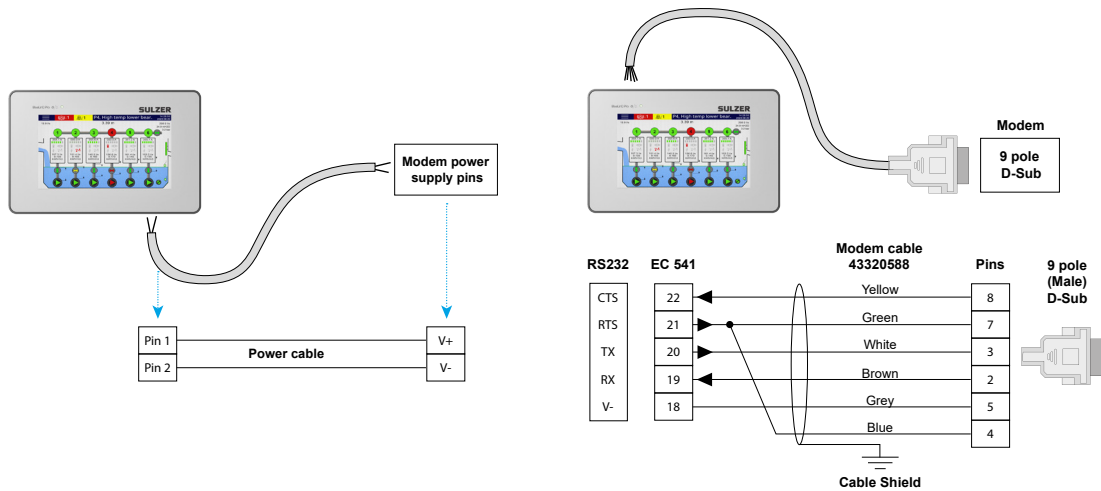

Figure 3.16: Connect BlueLinQ Pro to 9-pole D-Sub. Cable item no 43320588

TCP-Server

If you have a SIM card subscription with a fixed IP address, then you can connect the station by GPRS on a local network by using any of the CA-modems. Set the function in GPRS settings to TCP type server (fixed IP) which demands a SIM with fixed IP address from the provider on the station so that an external SCADA can contact remotely.

Settings under Communication – Modem – Modem type – settings GPRS in BlueLinQ Pro controller shall be set to [TCP type: TCP server (fixed IP)] or [TCP type: TCP server + heart beat].

Other types of modems

Profibus gateway and radio modems etc.

Connect CA-modem according to figure 3-16 to the com port on BlueLinQ Pro controller.

RS485 port (terminal 23-25 and 26-28)

There are two RS485 ports on BlueLinQ Pro controller for communication to surrounding units or to a SCADA-system. All the units in the RS485 network must be using the same communication parameters; baud rate, parity and stop bits. Compare the setting in the menu of BlueLinQ Pro and consult the manuals for surrounding units.

RS485 network is multi-drop which means that all units are connected in parallel on the same cable. In a RS485 network every unit must be connected in a line and have a unique address or Modbus ID-number. The RS485 bus shall be terminated with 120 ohms resistor at both cable ends. BlueLinQ Pro has a built-in jumper for end termination in terminal beside the connection terminals. The cable must be a shielded twisted pair cable.

The two RS485 busses on BlueLinQ Pro is galvanic isolated from the power supply and each other. If the surrounding units also have isolated communication ports, the common should be connected to ground potential in one point. The two ports operate independently of each other, so one port can work as a Master port, the other as Slave.

BlueLinQ Pro set as Master

If the BlueLinQ Pro is set to be the master in the RS485 network, all the surrounding units must be set as slaves. When BlueLinQ Pro act as a Master, the surrounding units can only be supported VFD's, Energy meters and Soft starters according to .

BlueLinQ Pro set as Slave

When BlueLinQ Pro controller is set as a "Slave" on the RS485 port, another master in the system request values from BlueLinQ Pro. The RS485 port act as communication port to a SCADA-system or similar.

USB port (USB type mini-B)

This port is only for updating firmware and upload / download configuration by using AquaProg.

RJ45 Ethernet port

BlueLinQ Pro controller has support for direct Ethernet communication through the RJ45 TCP / IP-port and handle up to 10 simultaneity connections.

In Settings > Communication > Ethernet port(TCP/IP)

Hardware [ON / OFF] Protocol [Modbus RTU or TCP]

Protocol ID, [1-255] Message timeout (1 sec, default)

Cross reference [ON / OFF] Port number (502 – default AquaProg)

Static / Dynamic IP (Dynamic DHCP – default)

When using only the TCP / IP port for communication, the modem port shall be set to OFF:

Communication > Modem > Modem connected [OFF]

BlueLinQ Pro controller has support for sending SMS simultaneously as Ethernet communications.

Field bus port (terminal 3-7 on BlueLinQ Pro controller)

The Field-bus port communicate with a CAN network interface. The protocol is unique for Sulzer and only Sulzers units can be connected to this bus. This CAN-bus is of multi drop type which means that all units are connected in parallel on the same cable. In a CAN network every type of unit must have a unique address or ID-number.

All the Sulzers different types of expansion units connected to the CAN-bus, have in a fact two bits addresses. The first byte is built-in in each module and can't be changed and says which type of module it is, and the second byte is the address switch in the front which can be changed.

3.9 Cross reference table

Cross reference table can be set-up in AquaProg to optimize the data flow in Modbus to the supervision system. Register 0-254 can be defined to hold preferred data by a cross reference table and can be set for data for any register. See further information in Modbus register manual.

Together with the cross-reference table, it is possible to set an individual scale factor for each position in the cross-reference list, e.g running time in seconds can be rescaled to minutes with the factor 60. The scale factor can be between 0-32767, with the factor 0 no rescaling is done.

When reading data, the value is divided with corresponding scale factor. When writing data, the value will be multiplied with corresponding scale factor. Scale factor is ignored when set to 0. For data in double registers (32 bits), the highest register number should be used together with scale factors. Writing to the highest double register number will also set data in the lower register number if scale factor is set. If scale factor is set to zero, each register is handled individually. Many registers allow negative values (signed 2's complement data). This can cause some systems to treat negative data as large positive numbers (ex. -1 is read as 65535 by the system). To avoid these causing problems there is the possibility to individually set cross reference registers to only positive data. Negative values will give zero readout.

Note: *Cross reference tables are only available to configure in AquaProg. In the menus of BlueLinQ Pro controller you have the possibility to activate or deactivate the table on each port separately.*

Settings > Communication > [any port] - Cross ref; Set to [ON or OFF]

For the modem port:

Settings > Communication > Modem port > Settings GPRS > Cross ref; Set to [ON or OFF]

By using AquaProg you can also save and download your cross-reference table to any other BlueLinQ Pro controller units.

3.10 Clock Functions

3.10.1 Clock Functions – Timer Relay:

The BlueLinQ Pro controller has 8 Timer Relays which are used to program the operating times for the pump control system.

Each Timer Relay can be repeated every Day, Week and Month and has 4 scheduled time sequences for ON/OFF operation.

The Timer Relay uses a digital output which is configured as a time relay output. Below are the digital output settings that need to be set to operate an output as a time relay:

Settings > In & outputs > Digital outputs > Module X > DO X > Signal function > Time relay > Settings:

- Time relay - Select the time relay output number to be configured on the module, ranging from 1 to 8.
- Sequence - Select which sequence number is to be configured to the time relay output.

To activate the Timer Relay, the following settings must be turned 'ON':

Settings > Clock functions > Time relays:

- Time relay X - Active (OFF/ON)

To set the time sequence of a Timer Relay, it is accessible in the following menu:

Settings > Clock functions > Time Relays > Time Relay X > Sequence X:

- Interval Base - OFF
- Choose the interval that you want the time relay to operate at.
Options include setting the interval to a day, week, day of the month, week of the month and to disable it in OFF mode.

In this example, we will use the option 'OFF' which turns off the time relay sequence and will not operate.

- Turn on time - 00:00:00 (hh:mm:ss) [Time to turn on system]
Not applicable as the sequence is OFF.
- Duration - 0 d (Enter Number)
Not applicable as the sequence is OFF.
- Duration - 00:00:00 (hh:mm:ss) [Length of time the system is on]
Not applicable as the sequence is OFF.

The 'Turn on time' and 'Duration' settings will be the same in the other functions, unless a difference is stated and therefore will not be repeated in next configuration settings.

When choosing a different Interval Base option, the sub-menu options will change depending on the type of operation chosen. Examples of the different options are seen below:

Settings > Clock functions > Time Relays > Time Relay X > Sequence X:

- Interval Base - Day
Choose the interval that you want the time relay to operate at. In this example, we will use the option 'Day'.
- Day > Repeat Every - day, 2nd day, 3rd day, 4th day, 5th day, 6th day, 7th day
Choose what day(s) to repeat the timer relay sequence.
- The 'Turn on time' and 'Duration' settings are the same as the previous function.

Settings > Clock functions > Time Relays > Time Relay X > Sequence X:

- Interval Base - Week
Choose the interval that you want the time relay to operate at. In this example, we will use the option 'Week'.
- Week > Repeat Every - week, 2nd week, 3rd week, 4th week, 5th week
Choose what week(s) to repeat the timer relay sequence.
- Week > Turn on day(s) - Monday, Tuesday, Wednesday, Thursday, Friday, Saturday, Sunday
Toggle ON the day(s) the timer relay operates, from Monday to Sunday.
- The 'Duration' settings are the same as the previous function.

Settings > Clock functions > Time Relays > Time Relay X > Sequence X:

- Interval Base - Month-date
Choose the interval that you want the time relay to operate at. In this example, we will use the option 'Month-date'.
- Month-date > Repeat Every - January, February, March, April, May, June, July, August, September, October, November, December
Toggle ON the month(s) to repeat the timer relay sequence.

- Month-date > Turn on day(s) - "Enter Number"
Select what day (date) the timer relay operates. Date range from 1-31.
- The 'Turn on time' and 'Duration' settings are the same as the previous functions.

Settings > Clock functions > Time Relays > Time Relay X > Sequence X:

- Interval Base - 1st week of month
Choose the interval that you want the time relay to operate at. In this example, we will use the option '1st week of month'.
- 1st week of month > Repeat Every - January, February, March, April, May, June, July, August, September, October, November, December
Toggle ON the month(s) to repeat the timer relay sequence.
- 1st week of month > Turn on day(s) - "Enter Number"
Toggle ON the day(s) the timer relay operates, from Monday to Sunday.
- Turn on time - 00:00:00 (hh:mm:ss) [Time to turn on system]
Enter the time the timer relay will turn on at.
- Duration - 0 d (Enter Number)
Enter the length of time (in days) the timer relay operates for.
- Duration - 00:00:00 (hh:mm:ss) [Length of time the system is on]
Enter the length of time (in hours) the timer relay operates for.

Settings > Clock functions > Time Relays > Time Relay X > Sequence X:

- Interval Base - 2nd week of month
Choose the interval that you want the time relay to operate at. In this example, we will use the option '2nd week of month'.
- Interval Base - 3rd week of month
Choose the interval that you want the time relay to operate at. In this example, we will use the option '3rd week of month'.
- Interval Base - 4th week of month
Choose the interval that you want the time relay to operate at. In this example, we will use the option '4th week of month'.
- Interval Base - 5th week of month
Choose the interval that you want the time relay to operate at. In this example, we will use the option '5th week of month'.
- The 'Repeat Every', 'Turn on day(s)', 'Turn on time' and 'Duration' settings are the same as the previous function.

All configuration settings can be seen in Table 5.24, in Chapter 5.

3.10.2 Clock Functions – Count down Timer:

The Count down timer function can be used to set a timer based on a Digital Input, IO status and various conditions of a data register. There are 12 count down timer functions available on the BlueLinQ Pro Controller.

The count down timer uses a digital output which is configured as a pulse timer output. Below are the digital output settings that need to be set to operate an output as a pulse timer:

Settings > In & outputs > Digital outputs > Module X > DO X > Signal function > Pulse timer:

- Settings > Signal source > Count down timer
Select the type of signal source for the digital output. The 'Count down timer' signal source must be selected, in order to configure the count down timer function.
- Settings > Signal source > Count down timer > Count down timer: 1-12
Select which count down timer this output is associated to. This count down timer output must correspond with the correct count down timer configuration ie. 'Count down timer 1'.
- Settings > Pulse time - "Enter Number"
Enter the length of time you want the digital output to pulse for when the count down timer has elapsed. The value is in seconds.

The count down timer can use any selectable trigger source to start the count down timer. We can use a digital input to trigger the count down timer to start elapsing the timer. This input can be configured as any type of alarm input, sensor or DI pulse channel etc.

To set up a count down timer, it is accessible through the following menus:

Settings > Clock functions > Count down timers > Count down timer X:

- Trigger source - OFF
Choose the type of trigger source that you want to start the count down timer with. In this example, we will use the option 'OFF' which turns off the trigger source and will not operate.
- Repetition(s) - Continuous, 1-9
Choose how often the count down timer is repeated. Options include continuous operation mode based on a digital input value or it can be repeated from 1-9 cycles.
- Duration - Duration - 00:00:00 (hh:mm:ss)
Select the length of time the count down timer will run for.
Enter a Tag Name for the Count down timer, which must be no more than 30 characters long.

In the next example, DI on is used as the trigger source for the count down timer:

Settings > Clock functions > Count down timers > Count down timer X:

- Trigger source - DI on
Choose the type of trigger source that you want to start the count down timer with. In this example, we will use the 'DI on' trigger source. This will trigger the count down timer to start once a digital input is ON.
- Trigger source > DI on > Module > Module 1-9
Choose the Module number of your trigger source. Up to 9 Modules are supported.
- Trigger source > DI on > Signal source > Signal source 1-12
Choose the Signal source channel for your trigger source. Each Module has Channels 1-12.
- Repetition(s) - Continuous, 1-9
Choose how often the count down timer is repeated. Options include continuous operation mode based on a digital input value or it can be repeated from 1-9 cycles.
- Duration - Duration - 00:00:00 (hh:mm:ss)
Select the length of time the count down timer will run for.
- Tag name - "Enter a Tag Name" (30 characters)
Enter a Tag Name for the Count down timer, which must be no more than 30 characters long.

In the next example, DI off is used as the trigger source for the count down timer:

Settings > Clock functions > Count down timers > Count down timer X:

- Trigger source - DI off
Choose the type of trigger source that you want to start the count down timer with. In this example, we will use the 'DI off' trigger source. This will trigger the count down timer to start once a digital input is OFF.
- The 'Module', 'Signal source', 'Repetition(s)', 'Duration' and 'Tag name' settings are the same as the previous function.

In the next example, IO on is used as the trigger source for the count down timer:

Settings > Clock functions > Count down timers > Count down timer X:

- Trigger source - IO on
Choose the type of trigger source that you want to start the count down timer with. In this example, we will use the 'IO on' trigger source. This will trigger the count down timer to start once the assigned IO bit is ON.
- Trigger source > IO on > IO number - "Enter Number"
The IO numbers can be found in the BlueLinQ Pro Modbus Table. For example, IO number 80 (Module #1 Digital Input #1) can be selected as the trigger source IO number.
- The 'Repetition(s)', 'Duration' and 'Tag name' settings are the same as the previous function.

In the next example, IO off is used as the trigger source for the count down timer:

Settings > Clock functions > Count down timers > Count down timer X:

- Trigger source – IO off
Choose the type of trigger source that you want to start the count down timer with. In this example, we will use the 'IO off' trigger source. This will trigger the count down timer to start once the assigned IO bit is OFF.
- Trigger source > IO off > IO number - "Enter Number"
The IO numbers can be found in the BlueLinQ Pro Modbus Table. For example, IO number 80 (Module #1 Digital Input #1) can be selected as the trigger source IO number.
- The 'Repetition(s)', 'Duration' and 'Tag name' settings are the same as the previous function.

In the next examples, we will be demonstrating the use of data registers to activate the count down timers. To do this, any register value can be used such as a user data register. The user data register must be configured using the submenu options below:

Using data registers, a count down timer can be started when the configured logical statement is 'True'. In the below example, the register used for 'Pump pit level' is used to start the count down timer once the function's logical statement is true.

The 'Pump pit level' register is '1' and uses increments that represent steps of 0.01m in the pump pit level. Therefore, if the value recorded in register '1' is '100', it would be a '1m' rise in the pump pit level. A count down timer could then be triggered when the data register value '1' is equal to the threshold value of '100'. Other logical statements could be used also to start the count down timer under different scenarios.

Settings > Clock functions > Count down timers > Count down timer X:

- Trigger source - Reg. not equal (!=)
Choose the type of trigger source that you want to start the count down timer with. In this example, we will use the 'Reg. not equal (!=)' trigger source. This will trigger the count down timer to start once the data user register is not equal to the value assigned to that register.
- Trigger source > Reg. not equal (!=) > Data register - "Enter Number"
Enter the data register number that is to be compared to the Threshold Value the user sets below. In this example, the data register used will be register '1' (pump pit level). The value stored in this register will correspond to the level in the pit.
- Trigger source > Reg. not equal (!=) > Threshold value - "Enter Value"
Enter the Threshold value you want to compare against the data register. This value is used in the logical condition to activate the count down timer once the condition is true. In the example above, the Threshold Value is set to '100' (1m) and must not equal the value stored in the data register.
- The 'Repetition(s)', 'Duration' and 'Tag name' settings are the same as the previous function.

Settings > Clock functions > Count down timers > Count down timer X:

- Trigger source - Reg. less than (<)
Choose the type of trigger source that you want to start the count down timer with. In this example, we will use the 'Reg. less than (<)' trigger source. This will trigger the count down timer to start once the data user register is less than the value assigned to that register.
- Trigger source > Reg. less than (<) > Data register - "Enter Number"
Enter the data register number that is to be compared to the Threshold Value the user sets below. In this example, the data register used will be register '1' (pump pit level). The value stored in this register will correspond to the level in the pit.
- Trigger source > Reg. less than (<) > Threshold value - "Enter Value"
Enter the Threshold value you want to compare against the data register. This value is used in the logical condition to activate the count down timer once the condition is true. In the example above, the Threshold Value is set to '100' (1m). The data register value must be less than the value stored as the threshold value.
- The 'Repetition(s)', 'Duration' and 'Tag name' settings are the same as the previous function.

Settings > Clock functions > Count down timers > Count down timer X:

- Trigger source - Reg. less or equal to (<=)

Choose the type of trigger source that you want to start the count down timer with. In this example, we will use the 'Reg. less or equal to (<=)' trigger source. This will trigger the count down timer to start once the data user register is less than or equal to the value assigned to that register.

- Trigger source > Reg. less or equal to (<=) > Data register - "Enter Number"

Enter the data register number that is to be compared to the Threshold Value the user sets below. In this example, the data register used will be register '1' (pump pit level). The value stored in this register will correspond to the level in the pit.

- Trigger source > Reg. less or equal to (<=) > Threshold value - "Enter Value"

Enter the Threshold value you want to compare against the data register. This value is used in the logical condition to activate the count down timer once the condition is true. In the example above, the Threshold Value is set to '100' (1m). The data register value must be less than or equal to the value stored as the threshold value.

- The 'Repetition(s)', 'Duration' and 'Tag name' settings are the same as the previous function.

Settings > Clock functions > Count down timers > Count down timer X:

- Trigger source - Reg. equal to (==)

Choose the type of trigger source that you want to start the count down timer with. In this example, we will use the 'Reg. equal to (==)' trigger source. This will trigger the count down timer to start once the data user register is equal to the value assigned to that register.

- Trigger source > Reg. equal to (==) > Data register - "Enter Number"

Enter the data register number that is to be compared to the Threshold Value the user sets below. In this example, the data register used will be register '1' (pump pit level). The value stored in this register will correspond to the level in the pit.

- Trigger source > Reg. equal to (==) > Threshold value - "Enter Value"

Enter the Threshold value you want to compare against the data register. This value is used in the logical condition to activate the count down timer once the condition is true. In the example above, the Threshold Value is set to '100' (1m). The data register value must be equal to the value stored as the threshold value.

- The 'Repetition(s)', 'Duration' and 'Tag name' settings are the same as the previous function.

Settings > Clock functions > Count down timers > Count down timer X:

- Trigger source - Reg. more or equal to (>=)

Choose the type of trigger source that you want to start the count down timer with. In this example, we will use the 'Reg. more or equal to (>=)' trigger source. This will trigger the count down timer to start once the data user register is more than or equal to the value assigned to that register.

- Trigger source > Reg. more or equal to (>=) > Data register - "Enter Number"

Enter the data register number that is to be compared to the Threshold Value the user sets below. In this example, the data register used will be register '1' (pump pit level). The value stored in this register will correspond to the level in the pit.

- Trigger source > Reg. more or equal to (>=) > Threshold value - "Enter Value"

Enter the Threshold value you want to compare against the data register. This value is used in the logical condition to activate the count down timer once the condition is true. In the example above, the Threshold Value is set to '100' (1m). The data register value must be greater than or equal to the value stored as the threshold value.

- The 'Repetition(s)', 'Duration' and 'Tag name' settings are the same as the previous function.

Settings > Clock functions > Count down timers > Count down timer X:

- Trigger source - Reg. more than (>)

Choose the type of trigger source that you want to start the count down timer with. In this example, we will use the 'Reg. more than (>)' trigger source. This will trigger the count down timer to start once the data user register is more than the value assigned to that register.

- Trigger source > Reg. more than (>) > Data register - "Enter Number"

Enter the data register number that is to be compared to the Threshold Value the user sets below. In this example, the data register used will be register '1' (pump pit level). The value stored in this register will correspond to the level in the pit.

- Trigger source > Reg. more than (>) > Threshold value - "Enter Value"

Enter the Threshold value you want to compare against the data register. This value is used in the logical condition to activate the count down timer once the condition is true. In the example above, the Threshold Value is set to '100' (1m). The data register value must be greater than the value stored as the threshold value.

- The 'Repetition(s)', 'Duration' and 'Tag name' settings are the same as the previous function.

3.11 Valve Control

3.11.1 Pump Valve

The BlueLinQ Pro controller can control Pump Valves through two different functions:

- One function uses a digital output as a 'Valve control' and the BlueLinQ Pro controller keeps the output active for the duration the valve shall be open (same as for pneumatic valves).
- The other function requires two digital outputs configured as a 'Valve open' signal and a 'Valve close' signal. The valves can be without end point contacts or with indication for one or both end contacts. End contacts are sensors or switches that detect or activate when the valve is either opened or closed fully. This signal is then detected by the BlueLinQ Pro controller and used as a feedback loop for operating the pump system.

Note: *If the pump has a run indication from a current transformer, digital input or over the RS485 ModBus signal, the valve is blocked until a run indication from the pump is received.*

Valve Control:

To run the Pump Valve in the 'Valve control' operation, a digital output is set up as a 'Valve Control' signal function. For pump valves with a single control mechanism, the output is active when the Pump Valve is open and inactive when the Pump Valve is closed.

Feedback via 'Valve open' & 'Valve close' signals:

You can configure the system to have feedback from the Pump Valve. To control the Pump Valve, two digital inputs and outputs must be configured. The digital inputs monitor the 'Valve open' and 'Valve close' state. The two digital outputs control the operation of the Pump Valve based on the 'Valve open' and 'Valve close' state.

Open and close delays can also be configured for the valves.

- Pump open delay' is the time the pump is running before the valve starts opening.
- Pump close delay' is the time the pump is running before the valve starts closing.

When end contacts are used and reached, the 'Valve open' or 'Valve close' outputs become deactivated. When 'Valve close' input signal is received by the BlueLinQ Pro controller, the pump will be stopped. This will occur even if the function 'Max. time to close' isn't elapsed. If detection of end contacts is not found within the pre-set 'Max. time to close', a closing sequence will be initiated again.

If you are not using the feedback method for the Pump Valve, then you can set a 'Max. time to open' and 'Max. time to close' settings for the Pump Valve. This is configured by the below submenu:

Settings > Pumps > PumpX > Pump valve:

- Max. time to open - "Enter Number" [60s Default]
Sets the maximum length of time that the system's control signal stays high for the pump valve to open. The value is measured in seconds with a default of 60 seconds.
- Max. time to close - "Enter Number" [60s Default]
Sets the maximum length of time that the system's control signal stays high for the pump valve to close. The value is measured in seconds with a default of 60 seconds.

If the 'Valve close' indication is missing, an alarm can be triggered, see below example. This alarm notifies the customer of the issue of the valve not closing and the pump can be blocked if the 'Block pump on alarm' function is enabled.

If the 'Valve open' indication is missing, an alarm will be triggered. This alarm notifies the customer that the valve has not opened, the pump will be blocked until the set-point is OFF (New attempt will be made next time the pump starts). If both 'Valve open' and 'Valve close' indications are received, a closing sequence will be made. The pump will remain blocked until the error is resolved. This will be indicated by alarm 'Pump valve error' if the alarm is configured, see below example.

Pump alarms must be set up for all these scenarios and they can be configured from the following submenu settings:

Settings > Pumps > PumpX > Pump alarms > Pump valve error:

- Alarm type - Inactive, B-alarm, A-alarm
Alarm triggered when the pump is blocked, affecting the pump valve. It is when the two indications 'Valve open' and 'Valve close' are active at the same time. Cleared once the issue is resolved. A closing sequence will be initiated if alarm is activated. Select the type of alarm to be used for the digital input. Options available are an Inactive alarm, B-Alarm and an A-Alarm type. Inactive alarm type will not trigger an alarm output. B-Alarm type will trigger an alarm and notification message. This alarm is less important and should be taken care of during normal work hours. A-Alarm type will trigger an alarm and notification message. This is a critical alarm that needs immediate action by the user.
- Alarm delay - "Enter Number"
Enter the length of time you want the alarm to delay for. The value is in seconds.
- Crash log trigger - NO/YES
Disable or enable the trigger for the alarm data to be generated in the Crash log.

Settings > Pumps > PumpX > Pump alarms > Pump open error:

- Alarm type – Inactive, B-alarm, A-alarm
Alarm triggered when the valve opening sequence doesn't complete within the set time. Cleared once the issue is resolved. Select the type of alarm type to be used for the digital input.

Options available are the same as the previous example.

- Alarm delay - "Enter Number"
Enter the length of time you want the alarm to delay for. The value is in seconds.
- Crash log trigger - NO/YES
Disable or enable the trigger for the alarm data to be generated in the Crash log.

Settings > Pumps > PumpX > Pump alarms > Pump close error:

- Alarm type - Inactive, B-alarm, A-alarm
Alarm triggered when the valve closing sequence doesn't complete within the set time. Cleared once the issue is resolved. Select the type of alarm type to be used for the digital input.

Options available are the same as the previous example.

- Alarm delay - "Enter Number"
Enter the length of time you want the alarm to delay for. The value is in seconds.
- Crash log trigger - NO/YES
Disable or enable the trigger for the alarm data to be generated in the Crash log.

If the 'Valve close' indication disappears a closing sequence will be initiated. If 'Valve close' indication doesn't reappear the pumps will be blocked as above. When the 'Valve open' indication disappears the 'Max. time to reopen' sequence will be initiated for the pre-set time. If 'Valve open' indication does not reappear the pumps will also be blocked as above.

The 'Block pump on alarm' function will only operate once the relevant pump alarms are configured first. To enable 'Block pump on alarm', the following sub-menu options are configured:

Settings > Pumps > PumpX > Pump alarms > Block pump on alarm:

- Pump valve error - NO/YES
Alarm triggered when there is a pump valve error occurring. This blocks the pump from operating. Cleared once the issue is resolved. The alarm parameters must be configured in the 'Pump alarms' menu. This function enables this alarm. It is when the two indications 'Valve open' and 'Valve close' are active at the same time.
- Valve open error - NO/YES
Alarm triggered when the valve opening sequence doesn't complete within the set time. The alarm parameters must be configured in the 'Pump alarms' menu. This function enables this alarm.
- Valve close error - NO/YES
Alarm triggered when the valve closing sequence doesn't complete within the set time. The alarm parameters must be configured in the 'Pump alarms' menu. This function enables this alarm.

If blocking is enabled, the pump is blocked until the above alarms are acknowledged by the user. Once the issue that triggered the alarm (pump valve error, open and close error) is resolved, the pump will restart operation again.

The pump valve can be fully configured by the following menus:

Settings > Pumps > PumpX > Pump valve:

- Pump open delay - "Enter Number" [10s Default]
Sets the delay time to open the valve after the pump has started to run. The value is measured in seconds with a default of 10 seconds.
- Pump close delay - "Enter Number" [60s Default]
Sets the delay time before closing the pump valve after receiving a stop signal for the pump. The value is measured in seconds with a default of 60 seconds.
- Max. time to open - "Enter Number" [60s Default]
Sets the maximum length of time that the system's control signal stays high for the pump valve to open. The value is measured in seconds with a default of 60 seconds.
- Max. time to close - "Enter Number" [60s Default]
Sets the maximum length of time that the system's control signal stays high for the pump valve to close. The value is measured in seconds with a default of 60 seconds.
- Max time to reopen - "Enter Number" [10s Default]
Sets the maximum length of time that the system waits to retry opening the pump valve. The value is measured in seconds with a default of 10 seconds.
- Close retry delay times - "Enter Number" [0s Default]
Sets the length of time that the system waits to retry closing the pump valve. The value is measured in seconds with a default of 0 seconds.

3.11.2 Pump pit valve

This function controls the main valve of the pump pit.

The valve opens as soon as any of the pumps in the pit starts and is closed when all pumps in the pit are switched 'OFF'. The pump(s) which are running at the start of a pit valve closing sequence will continue to run for the time set in 'Pump close delay'. Otherwise, the function is identical to Pump Valve.

Other information

If a level-controlled valve must be connected, a free pump can be used to set up the Pump valve without connecting any pump to the output.

Digital inputs and outputs are configured to control the operation of the Pump pit valve by providing open and closed indications and valve control.

The Digital outputs can be configured by the following menus:

Settings > In & Outputs > Digital outputs > Module X - DOX:

- Signal Function - OFF, Valve control, Valve open, Valve close, Time relay, Pulse timer
Choose the type of signal function that you want to configure the digital output as. Options include setting Valve Control, Valve open/close or Pulse timer.
- Signal Function > Object - Pump 1-6, Pump pit
Select the object in the pump control system that this output is controlling. In this example it is the pump pit.
- Status - ON/OFF
Shows the status of the digital output which is in use (ON) or not in use (OFF)
- Event trigger - OFF/ON
Disable/Enable the Event trigger which will log this operation in the Events list.

In this example, we will use the 'Valve open' signal function where a digital output will control the 'Valve open' operation of the Pump pit valve. This signal will stay high and commence the valve opening sequence of the Pump pit valve. Once the pump pit valve is opened, the signal will go low.

In the case of the 'Valve Control' signal function, the digital output will remain high to keep the Pump pit valve open. Once the signal goes low, the Pump pit valve closes.

The Digital inputs can be configured by the following menus:

Settings > In & Outputs > Digital inputs > Module X - DIX:

- Signal Function - OFF, Valve open, Valve close
Choose the type of signal function that you want to configure the digital input as. Options include setting Valve open/close. In this example, we will use the 'Valve open' signal function where a digital output will control the valve open operation of the pump pit valve.
- Signal Function > Status - ON/OFF
Shows the status of the digital input which is in use (ON) or not in use (OFF)
- Signal Function > Object - Pump 1-6, Pump pit
Select the object in the pump control system that this input is controlling. In this example it is the pump pit.
- Signal source - NO input terminal, NC input terminal, True IO number, Inv. IO number
Select the type of signal source that will activate the input. Options include setting the signal source as a NO input terminal, NC input terminal, True IO number or an Inv. IO number.
- Event trigger - OFF/ON
Disable or enable event trigger which will log the 'Valve open' notification in the events log.

This input signal represents that the 'Valve open' indication is activated, meaning the pump pit valve is fully open. This input is used as a feedback loop to the BlueLinQ Pro controller to detect when the Pump pit valve has opened fully.

The pump pit valve can be configured by the following menus:

Settings > Pump pit > Pump pit valve:

- Pump open delay - "Enter Number" [10s Default]
Sets the delay time before closing the pit valve after receiving a stop signal for all pumps. The value is in seconds with a default of 10 seconds.
- Pump close delay - "Enter Number" [60s Default]
Sets the delay time before closing the pit valve after receiving a stop signal for all pumps. The value is in seconds with a default of 60 seconds.
- Max. time to open - "Enter Number" [60s Default]
Sets the maximum length of time that the system's control signal stays high for the pump valve to open. The value is measured in seconds with a default of 60 seconds.

- Max. time to close - "Enter Number" [60s Default]
Sets the maximum length of time that the system's control signal stays high for the pump valve to close. The value is measured in seconds with a default of 60 seconds
- Max. time to reopen - "Enter Number" [10s Default]
This function is used for hydraulic/pneumatic valves that due to leaking pressure can lose the end contact during operation. Sets the maximum length of time that the system waits to retry opening the pump pit valve. The value is measured in seconds with a default of 10 seconds.
- Close retry delay time - "Enter Number" [0s Default]
Sets the maximum length of time that the system waits to retry closing the pump pit valve. The value is measured in seconds with a default of 0 seconds.

The above settings are used to control the operations of the Pump pit valve by setting the timing sequences of opening and closing the Pump pit valve.

Delays can be used to set the pump run time before a pump pit valve starts opening or starts closing. The maximum timings for opening and closing the Pump pit valve ensure that the system detects an issue with the pump pit valve if it does not open or close in the specified maximum timing.

If the Pump pit valve doesn't open or close within the specified timings, a reopen sequence or a close retry sequence is executed. This ensures that the Pump pit valve is fully functioning and set to the desired state after the re-try.

3.11.3 Alarm Valve Error

The pit valve error alarms can be configured by the following menus:

Settings > Pump pit > Pit alarms > Pit valve error:

- Alarm type - Inactive, B-alarm, A-alarm
Alarm triggered when both the 'Valve open' and 'Valve close' indications are received during the closing sequence. This will then block the pump until the error is solved.
- Alarm delay - "Enter Number"
Enter the length of time you want the alarm to delay for. The value is in seconds.
- Crash log trigger - NO/YES
Disable or enable the Crash log trigger which will either include/not include the alarm details in the crash log.

Settings > Pump pit > Pit alarms > Pit valve open error:

- Alarm type - Inactive, B-alarm, A-alarm
Alarm triggered when the valve opening sequence doesn't complete within the set time. Cleared once the issue is resolved.
- Alarm delay - "Enter Number"
Enter the length of time you want the alarm to delay for. The value is in seconds.
- Crash log trigger - NO/YES
Disable or enable the Crash log trigger which will either include/not include the alarm details in the crash log.

Settings > Pump pit > Pit alarms > Pit valve close error:

- Alarm type - Inactive, B-alarm, A-alarm
Alarm triggered when the valve closing sequence doesn't complete within the set time. Cleared once the issue is resolved.
- Alarm delay - "Enter Number"
Enter the length of time you want the alarm to delay for. The value is in seconds.
- Crash log trigger - NO/YES
Disable or enable the Crash log trigger which will either include/not include the alarm details in the crash log.

These alarms for the Pump pit valve will control the operation of the pump system if an error is detected with the Pump pit valve. If both the open and close indications are monitored, a 'Pit valve error' will occur. This means the Pump pit valve hasn't fully opened/closed or there is an issue with the 'Valve open' and 'Valve close' indications.

If the input 'Valve open' indication doesn't activate within the specified 'Max. time to open' timing sequence, then the alarm 'Pit valve open error' will be flagged.

The same operation will occur for the 'Valve close' operation where the input 'Valve close' indication doesn't activate within the specified 'Max. time to close' timing sequence, triggering the 'Pit valve close error' alarm.

3.12 IO controlled data

This function gives the possibility to manipulate data depending on the IO status. It works by setting different data values in registers based on the selected IO status, whether it's '0' (OFF) or '1' (ON). It allows for two types of operation to be executed based on the state of the IO. Data can be selected as a numeric value or be collected from another data register. Any data register value can be used to implement an operation based on this IO state which gives further functionality to the BlueLinQ Pro controller and the input and output options available to it.

There are 64 different IO that can be configured (16 bit user data reg. 1-32 - 11776-11807 & 16 bit user data reg. 33-64 - 11808-11839)

There are another 32 different IO that can be configured (32 bit user data reg. 1-32 - 11841-11903)

To change the IO-bit controlled data, it can be accessed from the following menus:

Settings > IO-bit controlled data > IO controlled data X:

- Register Control - OFF/ON
Enable or Disable the function for controlling registers. In this example, we will use the option 'ON' which allows the specified register to be used as an IO controlled bit.
- IO number - "Enter Number"
Enter the IO number, this is the number assigned to the specific IO which the user will use to compare IO's status with. Based on the status of the IO which is either ON or OFF, a specific operation will then be executed.
- Controls data register - "Enter Number"
Enter the data register number to be controlled. The value contained in this register will be changed dependant on the entered IO number.
- Source data when IO off (0) - Data value/Data register
Select the type of source data to be used when the IO state is OFF (0). Options are a data value or a data register.
- Data when IO off (0) - "Enter Number"
This sets the source data value to the value defined for when the IO's state is OFF (0). Depending on what the data source is set to, it can be a data value or point to a data register.
- Source data when IO on (1) - Data value/Data register
Select the type of source data to be used when the IO state is ON (1). Options are a data value or a data register.
- Data when IO on (1) - "Enter Number"
This sets the source data value to the value defined for when the IO's state is ON (1). Depending on what the data source is set to, it can be a data value or point to a data register.

Example of an application using IO controlled data:

Problem statement:

The customer needs the possibility to remotely limit the maximum number of pumps allowed to run in the sewage pump station controlled by the BlueLinQ Pro device.

The problem is that the local telemetry solution used does not support communication with the BlueLinQ Pro device.

The work around will then be that the customer remotely sets a digital output on their PLC that in turn is connected to a digital input in the BlueLinQ Pro controller, which reduces the number of allowed pumps to run according to a pre-set value.

Set-up example:

Digital input #12 of Module #1 is used to change the parameter 'Max. No. pumps running' in the BlueLinQ Pro controller. This signal is connected to customer's PLC which in turn is connected to the customer's SCADA system.

Digital input #12 = 0 (OFF)	The parameter is set to Max 6 Pumps
Digital input #12 = 1 (ON)	The parameter is set to Max 2 Pumps

The Digital input #12 can be configured with an Alarm input from the customer's PLC system which will trigger the IO status then. If the Alarm input is low, the pump system will operate at a maximum of 6 pumps. If the Alarm input is high, the pump system will then operate at a maximum of 2 pumps. This can be done by going through the following menu settings:

Settings > In & Outputs > Digital inputs > Module X > DIX:

- Signal Function - Alarm input
Choose the type of signal function that you want to configure the digital input as. In this example, we will configure the input as an Alarm Input as described above.
- Signal Function > Alarm input > Status - ON/OFF
Shows the status of the digital input which is in use (ON) or not in use (OFF).
- Signal Function > Alarm input > Alarm settings > Alarm type - Inactive, B-alarm, A-alarm
Types of alarms. Alarm triggered when the input terminal signal goes high. Cleared once the issue is resolved.
- Signal Function > Alarm input > Alarm settings > Alarm delay - "Enter Number"
Enter the length of time you want the alarm to delay for. The value is in seconds.
- Signal Function > Alarm input > Alarm settings > Alarm text - "Enter Name"
Enter a description of the Alarm.
- Signal Function > Alarm input > Alarm settings > Crash log trigger - NO/YES
Disable or enable the Crash log trigger which will either include/not include the alarm details in the crash log.
- Signal source - NO input terminal, NC input terminal, True IO number, Inv. IO number
Select the type of signal source that will activate the input. Options include setting the signal source as a NO input terminal, NC input terminal, True IO number or an Inv. IO number. In this example, using the Alarm input from the customer's PLC system, a low signal will have the IO deactivated and thus configure the system to operate in the 'Max. 6 pumps' operation. When the alarm input is high the IO will be activated and thus configure the system to operate in the 'Max. 2 pumps' operation.
- Event trigger - OFF/ON
Disable or enable event trigger which will log the 'Valve open' notification in the events log.

The first step is to set up the parameters needed to configure our 2 types of pumps operation - 2 pumps running and 6 pumps running. This is done by setting the two parameter values into two free user defined registers. Below is an example of the steps involved to do this:

Referring to the BlueLinQ Pro's ModBus Manual as seen below, you can see the configuration settings for 'Max. No. pumps running' is set in control data register #5122. Setting this register to '1' will configure the system to operate with a maximum of 2 pumps only. Setting this register to '5' will configure the system to operate with a maximum of 6 pumps only. These values can be seen highlighted in the image on the next page:

4.1 Common Pump settings

Min relay interval 1 s	RW	Unsigned	5121
Max No. pumps running 0=1, 1=2, 2=3, 3=4, 4=5, 5=6	RW	Unsigned	5122
Min no pumps available 0=1, 1=2, 2=3, 3=4, 4=5, 5=6	RW	Unsigned	5123

Figure 3.17: AquaProg view of SD card settings.

We have 64 freely definable 16 bit registers 11776 - 11839 and 32 freely definable 32 bit registers 11841 - 11903.

These registers are available via the following sub-menu options:

Settings > Free user data registers > 16 bit data reg. 1-32:

- 16 bit user data reg. XXXXX = 0

Select the first free register in the list, in this example we will use the data register #11776

11776 = 0

Enter the numerical value into this register. In this example we will use the parameter '5' to set the first pump operation which uses 'max. 6 pumps running'.

- 16 bit user data reg. XXXXX = 0

Select the next free register in the list, in this example we will use the data register #11777

11777 = 0

Enter the numerical value into this register. In this example we will use the parameter '1' to set the second pump operation which uses 'max. 2 pumps running'.

The next steps involve configuring the IO controlled data and setting the two pump operations based on the status of the IO. Firstly, check the BlueLinQ Pro ModBus Manual (ModBus IO bits) to identify the IO number of the selected input you want to use to trigger the IO controlled data operations.

In this example, the Digital input #12 will be used as the IO number that the BlueLinQ Pro controller will read the status from. The IO number for the IO Module 1 Digital input #12 is #91. This can be seen in the table below:

1.1.2 Digital inputs

DI Status 0=-OFF-, 1=-ON- RO 80 +(signal number -1)*1 +(Module number -1)*12

		Signal											
		DI1	DI2	DI3	DI4	DI5	DI6	DI7	DI8	DI9	DI10	DI11	DI12
Module	1	80	81	82	83	84	85	86	87	88	89	90	91
	2	92	93	94	95	96	97	98	99	100	101	102	103
	3	104	105	106	107	108	109	110	111	112	113	114	115
	4	116	117	118	119	120	121	122	123	124	125	126	127
	5	128	129	130	131	132	133	134	135	136	137	138	139
	6	140	141	142	143	144	145	146	147	148	149	150	151
	7	152	153	154	155	156	157	158	159	160	161	162	163
	8	164	165	166	167	168	169	170	171	172	173	174	175
	9	176	177	178	179	180	181	182	183	184	185	186	187
EC 541	188	189	190	191	-	-	-	-	-	-	-	-	

Figure 3.18: AquaProg view of SD card settings.

The next step is to now set the parameters of IO #91 and set the two types of output configuration when the IO state goes 'OFF' and 'ON'. To configure the IO-bit controlled data, it can be accessed from the following menus:

Settings > IO-bit controlled data > IO controlled data X:

- Register Control - OFF/ON
Disable or Enable the register control.
- IO number - "Enter Number"
Enter the IO number, which is the memory mapped number allocated for this specific IO configuration.
- Controls data register - "Enter Number"
Enter the Controls data register number, which is the register that's value is to be controlled or changed. An example of this is found in the Common Pump Settings where Max No. of Pumps Running is controlled by register 5122'.
- Source data when IO off (0) - Data value/Data register
Select the type of source data to be used when the IO state is OFF (0). Options are a data value or a data register.
- Data when IO off (0) - "Enter Value"
This sets the source data value to the value defined for when the IO's state is OFF (0). Depending on what the data source is set to, it can be a data value or point to a data register. In this example, the user register number should be entered, 11776
- Source data when IO on (1) - Data value/Data register
Select the type of source data to be used when the IO state is ON (1). Options are a data value or a data register.
- Data when IO on (1) - "Enter Value"
This sets the source data value to the value defined for when the IO's state is ON (1). Depending on what the data source is set to, it can be a data value or point to a data register. In this example, the user register number should be entered, 11777

To summarize, the following operations will happen once the IO state of Digital input #12 changes state:

When IO #91 state is 'OFF':

Source data value '11776' is used to change the value of the control register '5122'. The value stored in the user data register #11776 is '5'. This will set the value of the control register '5122' to '5' and the system will be configured to operate at 'max. 6 pumps' operation.

When IO #91 state is 'ON':

Source data value '11777' is used to change the value of the control register '5122'. The value stored in the user data register #11777 is '1'. This will set the value of the control register '5122' to '1' and the system will be configured to operate at 'max. 2 pumps' operation.

All is now set, when Digital input #12 is activated, the maximum number of pumps running is limited to 2 pumps and when Digital input #12 is deactivated, the maximum number of 6 pumps running is allowed again.

3.13 SD-Card/Functionality:

The micro-SD card can be used to save and load configuration file settings, save crash logs and perform firmware updates.

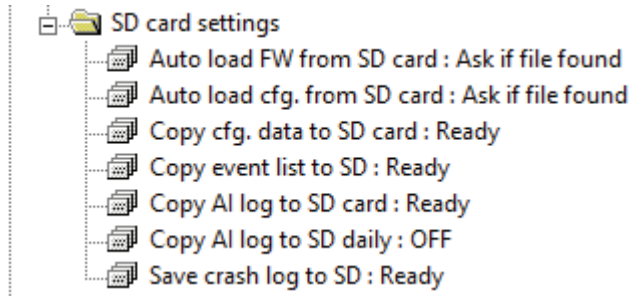

Figure 3.19: AquaProg view of SD card settings.

To use the SD card functionality, it can be accessed from the following menus:

Settings > System > SD card settings:

- Auto load FW from SD card - Never
In this setting the controller can automatically load the FW detected from the SD card. There are three options to select from, the first option:
Never load the FW automatically.
- Auto load FW from SD card - Ask if file found [Default]
The second option:
Ask to load the FW if a FW file is found on the SD card. This is the default operation.
- Auto load FW from SD card - Always if higher versions
The third option:
Always load the FW automatically if it is a higher version number than the FW installed on the controller.

Strict file naming of the FW update must be used. Only the 3 digits version number may be changed from the FW file, otherwise the FW file will be ignored by the system.

An example of the FW file is seen below:

```
\\Firmware\BlueLinQ_Pro_V101.smf
```

If the SD card is used on multiple controller units, then a log file is generated with the MAC ID of each unit. This file is created in the FW folder to ensure that the FW is just updated once for the same MAC ID. If the user wishes to force a new update with the same version FW, you simply delete or modify the log file and proceed to load the FW then.

Configuration settings of a BlueLinQ Pro controller can be loaded onto the controller via the SD card, saving time configuring a new system with a desired system setup. This option can be accessed in the following submenu below:

Settings > System > SD card settings:

- Auto load cfg from SD card - Never
This option will load the configuration file from the SD card onto the system. There are three options to select from, the first option:
Never load the configuration file automatically.
- Auto load cfg from SD card - Ask if file found [Default]
The second option:
Ask to load the configuration file if it is found on the SD card. This is the default operation.

- Auto load cfg from SD card - Always if higher versions

The third option:

Always load the configuration file automatically if it is a higher version number than the current configuration file on the system.

There are two ways the configuration file is saved as, when using the AquaProg format. If a configuration file (AP format) is saved on a loaded SD card, the BlueLinQ Pro controller will load or reload the configuration file on each boot and therefore it must align to the following naming convention:

\BlueLinQ_Pro.cfg

The file header type is ignored.

For configuration files (AP format) saved by the BlueLinQ Pro controller, it will save the configuration file using the following naming convention:

\BlueLinQ_Pro_MACID16hexdigits.cfg

Note, the MAC ID of the current system is represented as a 16 hexadecimal number within the configuration file name.

The file header type is:

[BlueLinQ Pro Config]

Configuration settings from a BlueLinQ Pro controller can be copied and saved to the SD card by the controller. This option can be used to save a good known configuration file setup of a BlueLinQ Pro controller or for replicating the setup on more controllers or replacement systems. This option can be accessed in the following submenu below:

Settings > System > SD card settings:

- Copy cfg to SD card - Ready [Default]

The user can copy the current configuration file or data from the BlueLinQ Pro controller to the SD card and transfer it to another system. There are three options to select from, the first option:

Ready, awaiting selection of the options below from the user. After execution of any of the below operations, the system returns to this state. This is the default operation state.

- Copy cfg to SD card - Configuration

The second option:

Configuration, this option copies configuration data from the system to the SD card.

- Config. And reg. logs - Always if higher versions

The third option:

Config. and reg. logs, this option copies configuration and register logs from the system to the SD card.

The BlueLinQ Pro controller can store an events list of the different types of events happening with the system. These event lists vary from alarms, system notifications to system faults and errors. This option can be accessed in the following submenu below:

Settings > System > SD card settings:

- Copy event list to SD - Ready [Default]

The events list of the BlueLinQ Pro controller can be copied to the SD card. There are two options to select from, the first option:

Ready, awaiting selection of the copy operation from the user. After execution of the copy operation, the system returns to this state. This is the default operation state.

- Copy event list to SD - To .txt file

The second option:

To .txt file, this executes the copy operation which will copy the events list to the SD card as a '.txt' file.

The location of manually saved events list is in the file:

`\Events.txt`

The BlueLinQ Pro controller can copy over all the log data generated from the system by the user prompt to save to the SD card. This option can be accessed in the following submenu below:

Settings > System > SD card settings:

- Copy AI log to SD card - Ready [Default]
All the log data of the BlueLinQ Pro controller can be copied to the SD card. There are three options to select from, the first option:
Ready, awaiting selection of the copy operation from the user. After execution of the copy operation, the system returns to this state. This is the default operation state.
- Copy AI log to SD card - Today's log data
The second option:
Today's log data, this option copies the data logged for the current day from the system to the SD card.
- Copy AI log to SD card - All log data
The third option:
All log data, this option copies all data logged for the system to the SD card.

The BlueLinQ Pro controller can copy over all of the log data generated from the system in an automated process and save it to the SD card daily. This option can be accessed in the following submenu below:

Settings > System > SD card settings:

- Copy AI log to SD daily - OFF [Default]
Daily log data of the BlueLinQ Pro controller can be copied to the SD card. There are three options to select from, the first option:
OFF, this option disables the daily logging of data to the SD card. This is the default operation state.
- Copy AI log to SD daily - To .txt file
The second option:
To .txt file, this option sets the type of file format that the daily data logs from the system are saved as on the SD card. In this case, the data is saved as a '.txt' file.
- Copy AI log to SD daily - To .xls file
The third option:
To .xls file, this option sets the type of file format that the daily data logs from the system are saved as on the SD card. In this case, the data is saved as a '.xls' file.

The location of manually saved or daily saved log files is in the folder:

`\Logdata`

The BlueLinQ Pro controller can save all crash log data generated from the system to the SD card. This option can be accessed in the following submenu below:

Settings > System > SD card settings:

- Save crash log to SD - Ready [Default]
The user can save the crash log from the BlueLinQ Pro controller to the SD card. There are three options to select from, the first option:
Ready, awaiting selection of the options below from the user. After execution of any of the below operations, the system returns to this state. This is the default operation state.

- Save crash log to SD - Last crash log

The second option:

Last crash log, this option saves the last crash log data generated from the system to the SD card.

- Save crash log to SD - All crash logs

The third option:

All crash logs, this option saves all the crash logs data generated from the system to the SD card.

The location of manually saved crash logs is in the folder:

`\Crashdata`

The maximum size SD card that the BlueLinQ Pro Controller can accept is 128Gb.

4. Further explanations of functions of the analog and digital input and output signals

4.1 Digital in: personnel alarm and local mode

This alarm is for the safety of service personnel. When digital input Local mode is set, a timer starts to elapse (Max time to reset). When timer has reached zero, a digital output can activate a connected buzzer or warning light to remind the service personnel to acknowledge their presence in the station by pressing any key on the controller. If the service personnel don't acknowledge the alarm within a certain time (Alarm delay), a callout will be done.

The Local mode input can for example be connected so that service personnel entering a station and turn on an indoor light (or similar) start the function

Required settings:

Setting > System > System alarms > Personnel alarm:

Type of alarm (A- or B-alarm) Max time to reset cyclic interval for personnel to acknowledge presence, typically 15-20 minutes Alarm delay: time between missed acknowledge and alarm call out, typically 120 seconds

Settings > In & Outputs > Digital input:

A digital input allocated as Local mode which is triggered by ta signal in the station (e.g. light switch) that indicates the service personnel is in the station. An active local mode signal will inhibit remote writing to most Modbus registers and IO-bits (USB and DSUB ports excluded). (Toggling of input signal Local mode or pressing key on display will reset alert timer Max time to reset.)

Settings > In & Outputs > Digital output:

Output signal Personnel alarm connected to a flashing light or buzzer can be used to get attention from the service personnel, to acknowledge the alert before an alarm goes active. (Toggling of input signal Local mode or pressing key on display will reset alert timer)

4.2 Digital in: block operation

This function enables a digital input to block the pump, mixer or drain pump. When the signal is active the pump / mixer / drain pump stops and blocks. The blocking will be released when the state of the input returns to a normal state.

4.3 Digital out: data register set point

A digital output can be configured with a Data register set point which can be associated with an internal or external analogue signal. By using the registers defined in the Modbus manual and entering them in the function as in the example below, you can achieve this function.

Example We have a sulfuric gas monitoring device connected to an analog input signal. We use first AI-module and last input, Ain:1:6 for the sulfuric meter. In this case we want a switch on digital output 1 on the first DO-module when the concentration of gas is equal to or above 10.0 ppm. We also want the output signal to switch off at 1.0 ppm (a hysteresis of 9 ppm). This digital output 1 controls a fan which evacuates the gas from the station.

The Modbus manual:

3.7 Analog IOs			
Analog inputs		Module 1-9 AI 1-6	
Current	RO	Signed2030 +(signal number -1) +(Module number -1)*6	0.01 mA

Figure 4.1: Above chart is an extract from the Modbus register manual

According to Modbus register manual, analog input number 6 on the first IO-module, have register number: 2030 +(signal number -1) +(Module number-1)*6 give us:

$$2030+(6-1)+(1-1)*6 = 2035$$

So register 2035 shall affect digital out 1:1 at 10 ppm to start a fan, and the fan shall stop at 1 ppm.

The property of the sulfuric meter is 20 mA at 20.0 ppm gas and 4 mA at 0.0 ppm. The start current from the sensor is then 12.0 mA and stop current at 4.8 mA.

The scaling of the modus register is 0.01 mA gives 12.0mA the value 1200 and 4.8 mA gives 480. In Aquaprog it looks like this:

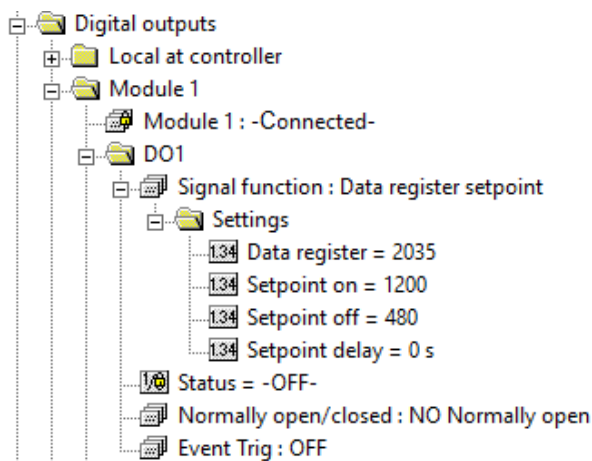

Figure 4.2: Data register setpoint example

4.4 Digital out: logic IO

One of the options in the functions of Digital out is **Logic IO**. This function is especially useful if you want to trigger an output signal when more than one criterion or events must occur to enable an output signal. There are up to four different criteria that can be used to trigger the output signal.

Those IO bits can be **Logical OR, NOR, And** or **NAND** functions or as a combination of these. The output signal can be set to Normally closed or Normally open (NC / NO).

This IO can be used to get a specific output signal from one or several indicators (up to 4 IO-bits). See table 4.1 below as an example of an output been driven by the state of 3 inputs.

4.5 Digital out: auto reset alert

Auto reset alert is active when a digital input is defined as Alarm reset. In the settings for Alarm reset input, there is a time delay value which can be set. This delay is the time the digital output Auto reset alert is active before the actual reset is performed.

Example The pumps are blocked because one or several alarms.

When pushing Alarm reset button, locally or remotely, which can imply that the pumps are about to start and there is a possibility of personnel being exposed to danger. The intention of this output is to give personnel a warning, if connected to buzzer or flashing light, that a reset of all alarms is about to happen, and the pumps might start.

4.6 Analog in: outlet pressure

If there is an outlet pressure sensor in the system, it will replace the system curve. Considering the backpressure, the level in the pit and the actual head. The signal from this sensor is recalculated into **Actual head** and used in the equation for the pump capacity calculation. This is a more accurate value for total head. When an outlet sensor is used, the total head parameter can be set to zero.

4.7 Analog out: data register and data register 2's complement

Data register

16-bit register from 0 to 65535. Only positive values. This type of register doesn't handle negative values. If there is a risk that the value could become negative, the register contains a very large value.

Data register 2's complement

16-bit register from -32767 to +32767. This type of register handles negative values.

With the analog output type data register, any analog signal, actual or calculated can be used as a 4-20 mA output signal. By using the registers defined in the Modbus manual and entering them in the function, you can achieve this function.

Example We want to have a 4-20 mA analog output signal tied to stator temperature L1 on pump 1. We also want the output signal to be 4 mA at 0°C and 20mA at 150 °C. We assume this temperature value never to be negative or goes below zero, even if the register type is "signed".

According to Modbus reference manual the temperature Stator L1 pump 1 is in register 703; see figure 4.3 below. We note as well that the scale factor is 0.1 (i.e. the value in reg.703 is multiplied by 0.1 to get accurate value in engineering units).

Temperature					
Stator L1	RO	Signed	703 +(pump number -1)*180	0.1 °C, 0.1 °F	
Stator L2	RO	Signed	704 +(pump number -1)*180	0.1 °C, 0.1 °F	
Stator L3	RO	Signed	705 +(pump number -1)*180	0.1 °C, 0.1 °F	
Upper bearing	RO	Signed	706 +(pump number -1)*180	0.1 °C, 0.1 °F	
Lower bearing	RO	Signed	707 +(pump number -1)*180	0.1 °C, 0.1 °F	
Generic	RO	Signed	708 +(pump number -1)*180	0.1 °C, 0.1 °F	
Vibration	RO	Signed	713 +(pump number -1)*180	0.1 mm/s ² , 0.01 in/h	

Figure 4.1: Above chart is an extract from the Modbus register manual

The function is setup in the BlueLinQ Pro menus according to figure 4.4 below;

Settings > In & Outputs > Analog outputs > Module 1 > AO1: > to [Data register] > Settings > Set data register = 703

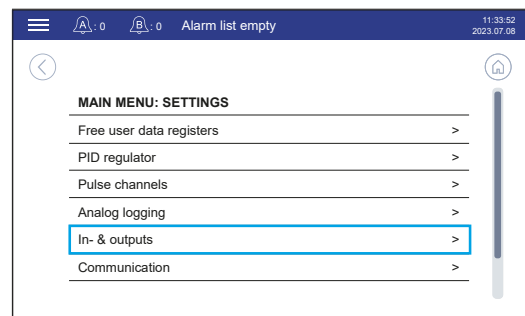
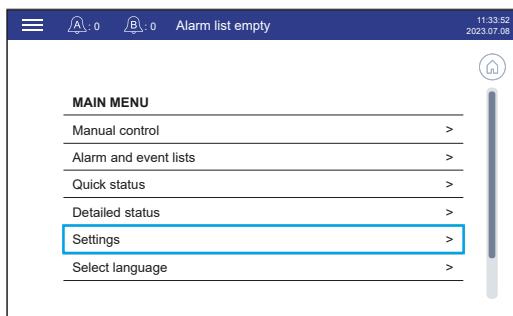

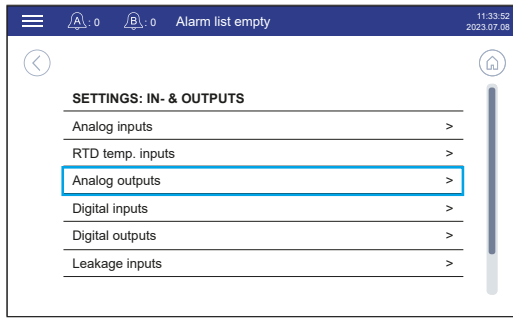

3

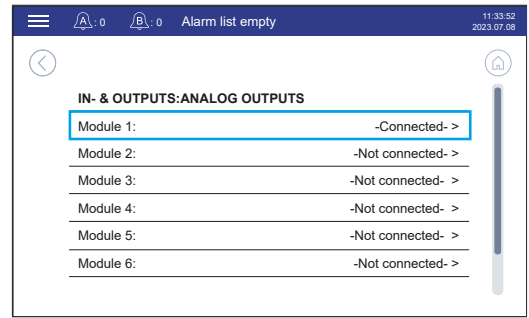

4

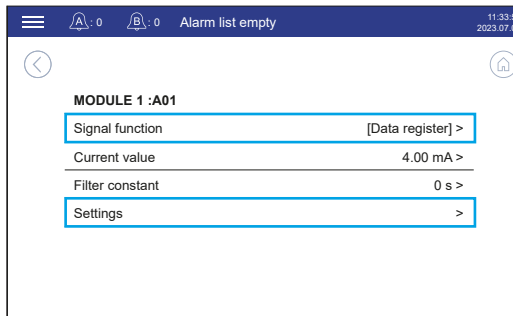

5

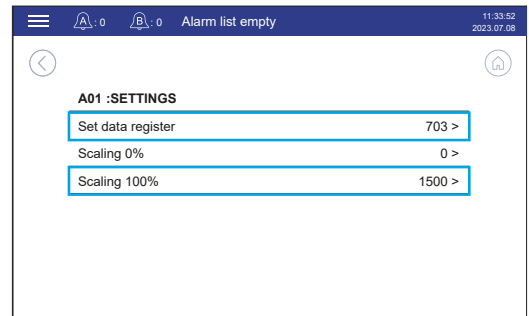

6

Figure 4.4 Data register setpoint example by the menus

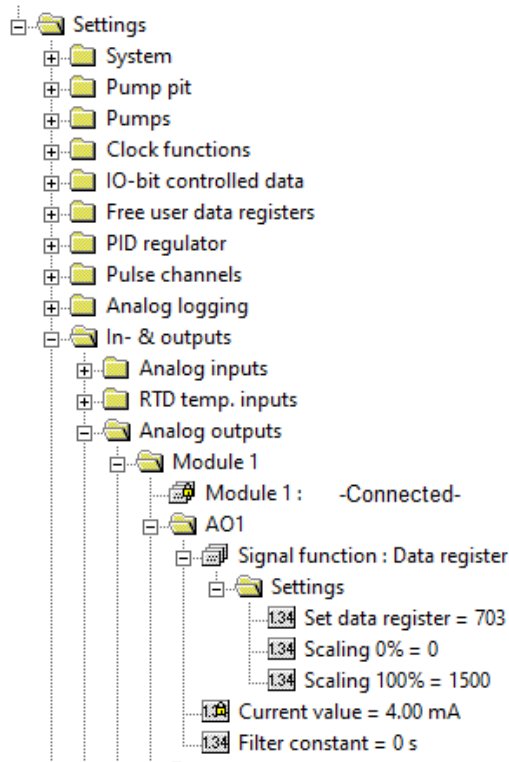

Figure 4.5: Analog output data register in Aquaprog

5. Appendix: BlueLinQ Pro Menu Guidelines

- 5.1 Manual control
- 5.2 Alarm and event lists
- 5.3 Quick status: System
- 5.4 Quick status: Pump pit
- 5.5 Quick status: Pumps
- 5.6 Quick status: Digital inputs
- 5.7 Quick status: Digital outputs
- 5.8 Quick status: Leakage inputs
- 5.9 Quick status: Analog inputs
- 5.10 Quick status: RTD temp. inputs
- 5.11 Quick status: Analog outputs
- 5.12 Detailed status: System
- 5.13 Detailed status: Pump pit
- 5.14 Detailed status: Pumps
- 5.15 Detailed status: PID regulator
- 5.16 Detailed status: Clock functions
- 5.17 Detailed status: Pulse channels
- 5.18 Detailed status: Inputs and outputs
- 5.19 Detailed status: Communication
- 5.20 Detailed status: Field bus modules (RS485)
- 5.21 Settings: System
- 5.22 Settings: Pump pit
- 5.23 Settings: Pumps
- 5.24 Settings: Clock functions
- 5.25 Settings: IO-bit controlled data
- 5.26 Settings: Free user data registers
- 5.27 Settings: PID regulator
- 5.28 Settings: Pulse channels
- 5.29 Settings: Analog logging
- 5.30 Settings: Inputs and outputs
- 5.31 Settings: Communication
- 5.32 Settings: Field bus modules (RS485)
- 5.33 Select language
- 5.34 Calibrate touch screen

5.1 Manual control

Table 5.1 shows the complete view for manual control.

Table 5.1

Submenu	Submenu	Setting / Value	Comment
Ackn. personnel alarm		NO, YES	Status value
Pump1	Manual start	NO, YES	Status value
	Pump reversing	NO, YES	Status value
	Fallen motor protect	NO, YES	Status value
	Reset motor prot.	NO, YES	Status value
	Reset temp. prot.	-OK-/ [YES], -Tripped-	Status value
	State of M-0-A switch	MANUAL, Pump not in auto, AUTO	Status value
	VFD frequency	0.01 Hz	Status value
	Set manual frequency	0.1 Hz	Status value
Pump2			Menu selection, Identical to above.
Pump3			Menu selection, Identical to above.
Pump4			Menu selection, Identical to above.
Pump5			Menu selection, Identical to above.
Pump6			Menu selection, Identical to above.
Mixer control	Start/Stop	STOP, START	Status value
	Run indication	NO, YES	Status value
	Reset motor prot.	NO, YES	Status value
Cleaning control	Start/Stop	STOP, START	Status value
Drain pump control	Start/Stop	STOP, START	Status value
	Run indication	NO, YES	Status value
	Reset motor prot.	NO, YES	Status value

5.2 Alarm and event lists

Table 5.2 shows the complete view for alarm and event lists.

Table 5.2

Submenu	Submenu	Setting / Value	Comment
Unackn. alarms	One or none of lines below, depending on port function.		
	Special Menu		
Active alarms	One or none of lines below, depending on port function.		
	Special Menu		
	One or none of lines below, depending on port function.		
IO events	One or none of lines below, depending on port function.		
	Special Menu		
	One or none of lines below, depending on port function.		
All events	One or none of lines below, depending on port function.		
	Special Menu		
	One or none of lines below, depending on port function.		
Group alarm acknowledge	Ackn. all pump 1 alarms	NO, YES	Status value
	Ackn. all pump 2 alarms	NO, YES	Status value
	Ackn. all pump 3 alarms	NO, YES	Status value
	Ackn. all pump 4 alarms	NO, YES	Status value

Submenu	Submenu	Setting / Value	Comment
Group alarm acknowledge	Ackn. all pump 5 alarms	NO, YES	Status value
	Ackn. all pump 6 alarms	NO, YES	Status value
	Ackn. all pump alarms	NO, YES	Status value
	Acknowledge all alarms	NO, YES	Status value

5.3 Quick status: System

Table 5.3 shows the complete view for quick status under the submenu **System**.

Table 5.3

Submenu	Submenu	Submenu	Submenu	Setting / Value	Comment	
EC 541 version	EC 541 version			0.01 [Unitless]	Status value	
	Option			1 [Unitless]	Status value	
	Hardware version			1 [Unitless]	Status value	
	Revision			[Text String]	Status value	
	Src timestamp:			[Text String]	Status value	
	Detailed status	SW build information	Module		[Text String]	Status value
			Status		[Text String]	Status value
			Comp.Ver: Build number:		[Text String]	Status value
			Src timestamp:		[Text String]	Status value
		SW build information				Menu selection, with preview, identical to above.
		SW build information				Menu selection, with preview, identical to above.
		SW build information				Menu selection, with preview, identical to above.
		SW build information				Menu selection, with preview, identical to above.
	I/O module SW versions	CA 811			0.01 [Unitless]	Status value
		CA 821			0.01 [Unitless]	Status value
		CA 831			0.01 [Unitless]	Status value
		CA 832			0.01 [Unitless]	Status value
		CA 841			0.01 [Unitless]	Status value
		CA 861			0.01 [Unitless]	Status value
	I/O module HW versions	CA 811			1 [Unitless]	Status value
		CA 821			1 [Unitless]	Status value
		CA 831			1 [Unitless]	Status value
		CA 832			1 [Unitless]	Status value
		CA 841			1 [Unitless]	Status value
		CA 861			1 [Unitless]	Status value
	Supply voltage				0.1 V DC	Status value
	PCB temperature				1 °C, 1 °F	Status value
Remote config. blocked				NO, YES	Status value	
SD card ready				NO, YES	Status value	
System time				[Text String]	Status value	
Power monitor	Current			0.1 A	Status value	
	Line current L1			0.1 A	Status value	
	Line current L2			0.1 A	Status value	
	Line current L3			0.1 A	Status value	
	Average LN voltage			0.1 V	Status value	
	Line voltage L1			0.1 V	Status value	
	Line voltage L2			0.1 V	Status value	

Submenu	Submenu	Submenu	Submenu	Setting / Value	Comment
Power monitor	Line voltage L3			0.1 V	Status value
	Average LL voltage			0.1 V	Status value
	L1-L2 voltage			0.1 V	Status value
	L2-L3 voltage			0.1 V	Status value
	L3-L1 voltage			0.1 V	Status value
	Power			0.1 kW	Status value
	Current frequency			0.01 Hz	Status value
	Power factor			0.01 [Unitless]	Status value
Power on time	Total			1 s, displayed as h:m:s	Setting, System Password
	Today			1 s, displayed as h:m:s	Setting, System Password
	Yesterday			1 s, displayed as h:m:s	Setting, System Password
Number of power on (boot)	Total			1 [Unitless]	Setting, System Password
	Today			1 [Unitless]	Setting, System Password
	Yesterday			1 [Unitless]	Setting, System Password

5.4 Quick status: Pump pit

Table 5.4 shows the complete view for quick status under the submenu **Pump pit**.

Table 5.4

Submenu	Submenu	Submenu	Submenu	Setting / Value	Comment
Pit level				0.01 m, 0.01 ft	Status value
Inflow				0.1 l/s, 1 GPM	Status value
Outflow				0.1 l/s, 1 GPM	Status value
Outlet pressure				0.1 bar, 0.1 PSI	Status value
Total pump head				0.01 m, 0.01 ft	Status value
Actual pump head				0.01 m, 0.01 ft	Status value
Overflow level				1 mm, 0.01 in	Status value
Overflow flow				0.1 m ³ /h, 1 GPM	Status value
High tariff active				NO, YES	Status value
High level				NO, YES	Status value
Low level				NO, YES	Status value
High-level float				NO, YES	Status value
Low-level float				NO, YES	Status value
High inflow				NO, YES	Status value
Low inflow				NO, YES	Status value
Backup start				NO, YES	Status value
High pressure				NO, YES	Status value
Low pressure				NO, YES	Status value
Overflow sensor				NO, YES	Status value
Overflow level				NO, YES	Status value
Sensor error	Sensor error			NO, YES	Status value
	Incor. lvl. low float			NO, YES	Status value
	Incor. lvl. high float			NO, YES	Status value
	Level is not changing			NO, YES	Status value
	Pit level			0.01 m, 0.01 ft	Status value
Detailed status	Pit level			0.01 m, 0.01 ft	Status value
	Pit volume			1 l, 1 gal	Status value

Submenu	Submenu	Submenu	Submenu	Setting / Value	Comment	
Detailed status	Pumped volume	Total		0.1 m3, 1 gal	Setting, System Password	
		Today		0.1 m3, 1 gal	Setting, System Password	
		Yesterday		0.1 m3, 1 gal	Setting, System Password	
	Energy consumption	Total		0.1 kWh	Setting, System Password	
		Today		0.1 kWh	Setting, System Password	
		Yesterday		0.1 kWh	Setting, System Password	
	Pit efficiency	Average		0.001 kWh/m3, 1 kWh/Mgal	Setting, System Password	
		Today		0.001 kWh/m3, 1 kWh/Mgal	Setting, System Password	
		Yesterday		0.001 kWh/m3, 1 kWh/Mgal	Setting, System Password	
	All pumps run #	Total		1 [Unitless]	Setting, System Password	
		Today		1 [Unitless]	Setting, System Password	
		Yesterday		1 [Unitless]	Setting, System Password	
	All pumps run time	Total		1 s, displayed as h:m:s	Setting, System Password	
		Today		1 s, displayed as h:m:s	Setting, System Password	
		Yesterday		1 s, displayed as h:m:s	Setting, System Password	
	Pit overflow	Overflow		NO, YES	Status value	
		Overflow level		1 mm, 0.01 in	Status value	
		Overflow flow		0.1 l/s, 1 GPM	Status value	
		Overflow time	Total		1 s, displayed as h:m:s	Setting, System Password
			Today		1 s, displayed as h:m:s	Setting, System Password
			Yesterday		1 s, displayed as h:m:s	Setting, System Password
		Overflow volume	Total		0.1 m3, 1 gal	Setting, System Password
			Today		0.1 m3, 1 gal	Setting, System Password
			Yesterday		0.1 m3, 1 gal	Setting, System Password
		No. of overflows	Total		1 [Unitless]	Setting, System Password
			Today		1 [Unitless]	Setting, System Password
			Yesterday		1 [Unitless]	Setting, System Password
		Main pwr. mon.			NO, YES	Status value
		Secondary pit level			0.01 m, 0.01 ft	Status value
		Pit level difference			0.01 m, 0.01 ft	Status value
	Pump pit valve	Valve state		Closed, Open	Status value	
		Open detect		NO, YES	Status value	
		Close detect		NO, YES	Status value	
	Drain pump	Drain pump float		OFF, ON	Status value	
		Terminal I/O status		OFF, ON	Status value	
		Run indication		NO, YES	Status value	
		Fallen motor protect		NO, YES	Status value	
		High temperature		NO, YES	Status value	

Submenu	Submenu	Submenu	Submenu	Setting / Value	Comment	
Detailed status	Drain pump	Leakage		NO, YES	Status value	
		Externally blocked		NO, YES	Status value	
		Running time	Total		1 s, displayed as h:m:s	Setting, System Password
			Today		1 s, displayed as h:m:s	Setting, System Password
			Yesterday		1 s, displayed as h:m:s	Setting, System Password
		Number of starts	Total		1 [Unitless]	Setting, System Password
			Today		1 [Unitless]	Setting, System Password
			Yesterday		1 [Unitless]	Setting, System Password
		Mixer	Terminal I/O status		OFF, ON	Status value
	Run indication			NO, YES	Status value	
	Fallen motor protect			NO, YES	Status value	
	High temperature			NO, YES	Status value	
	Leakage			NO, YES	Status value	
	Externally blocked			NO, YES	Status value	
	Running time		Total		1 s, displayed as h:m:s	Setting, System Password
			Today		1 s, displayed as h:m:s	Setting, System Password
			Yesterday		1 s, displayed as h:m:s	Setting, System Password
	Number of starts		Total		1 [Unitless]	Setting, System Password
			Today		1 [Unitless]	Setting, System Password
			Yesterday		1 [Unitless]	Setting, System Password
	Cleaner	Terminal I/O status		OFF, ON	Status value	

5.5 Quick status: Pumps

Table 5.5 shows the complete view for quick status under the submenu **Pumps**.

Table 5.5

Submenu	Submenu	Submenu	Submenu	Submenu	Submenu	Setting / Value	Comment
Pump1	Running time	Total				1 s, displayed as h:m:s	Setting, System Password
		Today				1 s, displayed as h:m:s	Setting, System Password
		Yesterday				1 s, displayed as h:m:s	Setting, System Password
	Number of starts	Total				1 [Unitless]	Setting, System Password
		Today				1 [Unitless]	Setting, System Password
		Yesterday				1 [Unitless]	Setting, System Password
	Start level					0.01 m, 0.01 ft	Status value
	Stop level					0.01 m, 0.01 ft	Status value
	Pump capacity					0.1 l/s, 1 GPM	Status value
	Pump flow					0.01 l/s, 1 GPM	Status value

Submenu	Submenu	Submenu	Submenu	Submenu	Submenu	Setting / Value	Comment				
Pump1	Calc. pump flow					0.01 l/s, 1 GPM	Status value				
	External meter pump flow					0.01 l/s, 1 GPM	Status value				
	Motor current					0.1 A	Status value				
	Motor power					0.1 kW	Status value				
	Last pump capacity					0.1 l/s, 1 GPM	Status value				
	Starts since pump reverse					1 [Unitless]	Status value				
	Blocked	Externally blocked	Blocked				NO, YES	Status value			
			Externally blocked				NO, YES	Status value			
				Pump not in auto				NO, YES	Status value		
				Remote blocking				NO, YES	Status value		
				Outlet pressure				NO, YES	Status value		
				Mixer control				NO, YES	Status value		
				Phase missing				NO, YES	Status value		
				Over voltage				NO, YES	Status value		
				Under voltage				NO, YES	Status value		
				Unbalanced voltage				NO, YES	Status value		
			Error blocked	Error blocked				NO, YES	Status value		
					Fallen temp. prot.				NO, YES	Status value	
					Pump blocking	Pump blocking			NO, YES	Status value	
						No run indication				NO, YES	Status value
						Fallen motor prot.				NO, YES	Status value
						High motor current				NO, YES	Status value
						DI pump error				NO, YES	Status value
						High vibrations				NO, YES	Status value
						Max. reverse attempts				NO, YES	Status value
				Pump valve error					NO, YES	Status value	
			Valve open error					NO, YES	Status value		
			Valve close error					NO, YES	Status value		
			Leakage	Generic			NO, YES	Status value			
				Oil chamber				NO, YES	Status value		
				Motor housing				NO, YES	Status value		
				Electr. con. box				NO, YES	Status value		
		Temperature	Generic			NO, YES	Status value				
			Stator L1				NO, YES	Status value			
			Stator L2				NO, YES	Status value			
			Stator L3				NO, YES	Status value			
		Pump blocking	Temperature	Upper bearing		NO, YES	Status value				
				Lower bearing				NO, YES	Status value		

Submenu	Submenu	Submenu	Submenu	Submenu	Submenu	Setting / Value	Comment		
Pump1	Blocked	Error blocked	Pump holding	Pump holding		NO, YES	Status value		
				Fallen motor prot.		NO, YES	Status value		
				DI pump error		NO, YES	Status value		
				Phase missing		NO, YES	Status value		
				M.Drive com. error		NO, YES	Status value		
				M.Drive error		NO, YES	Status value		
				High vibrations		NO, YES	Status value		
				Leakage	Generic		NO, YES	Status value	
					Oil chamber		NO, YES	Status value	
					Motor housing		NO, YES	Status value	
					Electr. con. box		NO, YES	Status value	
				Temperature	Generic		NO, YES	Status value	
					Stator L1		NO, YES	Status value	
					Stator L2		NO, YES	Status value	
	Stator L3		NO, YES		Status value				
	Upper bearing		NO, YES		Status value				
	Lower bearing		NO, YES		Status value				
	Detailed status	Tag name					[Text String]	Status value	
		Pump control					OFF, ON	Status value	
		Run indication					OFF, Ready to run, Running, Error run, Blocked, Error blocked, Pump reversing	Status value	
		State of M-0-A switch					MANUAL, Pump not in auto, AUTO	Status value	
		Pump fail					NO, YES	Status value	
		Pump exercising					NO, YES	Status value	
		Reverse					NO, YES	Status value	
		Reverse attempt cnt					1 [Unitless]	Status value	
		Reverse status					-OK-, Timer blocked, !NOT DEFINED TEXT!	Status value	
		Leakage	Leakage					NO, YES	Status value
			Generic					NO, YES	Status value
Oil chamber							NO, YES	Status value	
Motor housing							NO, YES	Status value	
Electr. con. box							NO, YES	Status value	
Temperature	Temperature					NO, YES	Status value		
	Generic					0.1 °C, 0.1 °F	Status value		
	Stator L1					0.1 °C, 0.1 °F	Status value		
	Stator L2					0.1 °C, 0.1 °F	Status value		
	Stator L3					0.1 °C, 0.1 °F	Status value		
	Upper bearing					0.1 °C, 0.1 °F	Status value		
Lower bearing					0.1 °C, 0.1 °F	Status value			
Vibration						0.1 mm/s ² , 0.01 in/h	Status value		

Submenu	Submenu	Submenu	Submenu	Submenu	Submenu	Setting / Value	Comment	
Pump1	Detailed status	Best efficiency point	Filtered effic. index			[User defined Unit]	Status value	
			Last raw effic. index			[User defined Unit]	Status value	
			Drive start ramp			1 s	Status value	
			Energy efficiency			0.0001 kWh/m ³ , 0.0001 kWh/Mgal	Status value	
			BEP frequency			0.01 Hz	Setting, System Password	
			BEP last step direction			-Decrease-, -Increase-, Retune	Setting, System Password	
			BEP step			0.01 Hz	Setting, System Password	
			BEP override	Pump at max. freq.			NO, YES	Status value
				Pump start counter			NO, YES	Status value
				All pumps running			NO, YES	Status value
		High level alarm				NO, YES	Status value	
		Pump valve	Valve state			Closed, Open	Status value	
			Open detect			NO, YES	Status value	
			Close detect			NO, YES	Status value	
		Logs	Running time	Total			1 s, displayed as h:m:s	Setting, System Password
				Today			1 s, displayed as h:m:s	Setting, System Password
				Yesterday			1 s, displayed as h:m:s	Setting, System Password
			Number of starts	Total			1 [Unitless]	Setting, System Password
				Today			1 [Unitless]	Setting, System Password
				Yesterday			1 [Unitless]	Setting, System Password
			Energy consumption	Total			0.1 kWh	Setting, System Password
				Today			0.1 kWh	Setting, System Password
				Yesterday			0.1 kWh	Setting, System Password
			Pump efficiency	Average			0.001 kWh/m ³ , 1 kWh/Mgal	Setting, System Password
				Today			0.001 kWh/m ³ , 1 kWh/Mgal	Setting, System Password
				Yesterday			0.001 kWh/m ³ , 1 kWh/Mgal	Setting, System Password
Pumped volume	Total				1 l, 0.1 gal	Setting, System Password		
	Today				1 l, 0.1 gal	Setting, System Password		

Submenu	Submenu	Submenu	Submenu	Submenu	Submenu	Setting / Value	Comment		
Pump1	Detailed status	Logs	Pumped volume	Yesterday		1 l, 0.1 gal	Setting, System Password		
			Pump capacity	Reference head			0.01 m, 0.01 ft	Status value	
				Today			0.1 l/s, 1 GPM	Setting, System Password	
				Yesterday			0.1 l/s, 1 GPM	Setting, System Password	
		Pwr.mon.	Pwr. mon.	Connected				-Not connected-, -Connected-	Status value
				Com. error				-OK-, -Error-	Status value
			Status	Current				0.1 A	Status value
				Line current L1				0.1 A	Status value
				Line current L2				0.1 A	Status value
				Line current L3				0.1 A	Status value
				Average LN voltage				0.1 V	Status value
				Line voltage L1				0.1 V	Status value
				Line voltage L2				0.1 V	Status value
				Line voltage L3				0.1 V	Status value
				Average LL voltage				0.1 V	Status value
				L1-L2 voltage				0.1 V	Status value
				L2-L3 voltage				0.1 V	Status value
				L3-L1 voltage				0.1 V	Status value
				Power				0.1 kW	Status value
				Current frequency				0.01 Hz	Status value
				Power factor				0.01 [Unitless]	Status value
		M.Drive	M.Drive	Connected				-Not connected-, -Connected-	Status value
				error				-OK-, -Error-	Status value
				Com. error				-OK-, -Error-	Status value
			Drive status	M.Drive not ready				OFF, ON	Status value
				Drive status				OFF, Running, Tune in, Fault, Unknown state	Status value
				Current frequency				0.01 Hz	Status value
				Rotation speed				1 rpm	Status value
				Motor voltage				0.1 V	Status value
				Motor power				0.1 kW	Status value
				Current				0.1 A	Status value
		Torque Nm				1 Nm, 1 lbf.ft	Status value		
		Torque %				0.1 %	Status value		
Pump2 - Pump6 = Menu selection, Identical to above.									

5.6 Quick status: Digital inputs

Table 5.6 shows the complete view for quick status under the submenu **Digital inputs**.

Table 5.6

Submenu	Setting / Value	Comment
Local at controller	[Graphical representation]	Status value
Module 1	[Graphical representation]	Status value
Module 2	[Graphical representation]	Status value
Module 3	[Graphical representation]	Status value
Module 4	[Graphical representation]	Status value
Module 5	[Graphical representation]	Status value
Module 6	[Graphical representation]	Status value
Module 7	[Graphical representation]	Status value
Module 8	[Graphical representation]	Status value
Module 9	[Graphical representation]	Status value
Settings	Logical I/O status, Terminal I/O status	Direct Setting

5.7 Quick status: Digital outputs

Table 5.7 shows the complete view for quick status under the submenu **Digital outputs**.

Table 5.7

Submenu	Setting / Value	Comment
Local at controller	[Graphical representation]	Status value
Module 1	[Graphical representation]	Status value
Module 2	[Graphical representation]	Status value
Module 3	[Graphical representation]	Status value
Module 4	[Graphical representation]	Status value
Module 5	[Graphical representation]	Status value
Module 6	[Graphical representation]	Status value
Module 7	[Graphical representation]	Status value
Module 8	[Graphical representation]	Status value
Module 9	[Graphical representation]	Status value
Settings	Logical I/O status, Terminal I/O status	Direct Setting

5.8 Quick status: Leakage inputs

Table 5.8 shows the complete view for quick status under the submenu **Leakage inputs**.

Table 5.8

Submenu	Setting / Value	Comment
Module 1	[Graphical representation]	Status value
Module 2	[Graphical representation]	Status value
Module 3	[Graphical representation]	Status value
Module 4	[Graphical representation]	Status value
Module 5	[Graphical representation]	Status value
Module 6	[Graphical representation]	Status value

5.9 Quick status: Analog inputs

Table 5.9 shows the complete view for quick status under the submenu **Analog inputs**.

Table 5.9

Submenu	Submenu	Setting	Setting / Value	Comment	
Module 1	Module 1		-Not connected-, -Reconnecting-, -Not connected-, -Connected-, -Error-, -Error-, -Not connected-, CAN ID error, CAN ID error	Status value	
Module 1	AI1	Signal function	OFF, Pit level, Motor current, Outlet pressure, Vibrations, Outflow meter, Motor temperature, Secondary pit level, Free choice	Status value	
		One or none of lines below, depending on port function.			
		Current value	0.1 A	Status value	
		Current value	0.1 bar, 0.1 PSI	Status value	
		Current value	0.1 mm/s ² , 0.01 in/h	Status value	
		Current value	0.1 l/s, 1 GPM	Status value	
		Current value	0.1 °C, 0.1 °F	Status value	
		Current value	0.01 m, 0.01 ft	Status value	
		Current value	[User defined Unit]	Status value	
		One or none of lines below, depending on port function.			
		Object	Pump pit, Pump 1, Pump 2, Pump 3, Pump 4, Pump 5, Pump 6	Status value	
		Object	Pump 1, Pump 2, Pump 3, Pump 4, Pump 5, Pump 6	Status value	
		Designation	[Text String]	Status value	
		One or none of lines below, depending on port function.			
		Measure point	Generic, Stator L1, Stator L2, Stator L3, Upper bearing, Lower bearing	Status value	
		Current	0.01 mA	Status value	
		AI2 - AI6 = Menu selection, with preview, identical to above.			
Module 2 - 9 = Menu selection, with preview, identical to above.					

5.10 Quick status: RTD temperature inputs

Table 5.10 shows the complete view for quick status under the submenu **RTD temperature inputs**.

Table 5.10

Submenu	Submenu	Submenu	Setting / Value	Comment	
Module 1	Module 1 RTD1		-Not connected-, -Reconnecting-, -Not connected-, -Connected-, -Error-, -Error-, -Not connected-, CAN ID error, CAN ID error	Status value	
		Signal function	OFF, Motor temperature, Free choice	Status value	
		One or none of lines below, depending on port function.			
		Object	Pump 1, Pump 2, Pump 3, Pump 4, Pump 5, Pump 6	Status value	
		One or none of lines below, depending on port function.			

Submenu	Submenu	Submenu	Setting / Value	Comment	
Module 1	RTD1	Measure point	Generic, Stator L1, Stator L2, Stator L3, Upper bearing, Lower bearing	Status value	
		Designation	[Text String]	Status value	
		One or none of lines below, depending on port function.			
		Current value	0.1 °C, 0.1 °F	Status value	
		Current value	-OK-, -Tripped-	Status value	
	RTD2 - RTD6 = Menu selection, with preview, identical to above.				
Module 2 - 9 = Menu selection, with preview, identical to above.					

5.11 Quick status: Analog outputs

Table 5.11 shows the complete view for quick status under the submenu **Analog outputs**.

Table 5.11

Submenu	Submenu	Setting / Value	Comment
Module 1	Module 1	-Not connected-, -Reconnecting-, -Not connected-, -Connected-, -Error-, -Error-, -Not connected-, CAN ID error, CAN ID error	Status value
	AO1	0.01 mA	Status value
	AO2	0.01 mA	Status value
	AO3	0.01 mA	Status value
	AO4	0.01 mA	Status value
	AO5	0.01 mA	Status value
	AO6	0.01 mA	Status value
Module 2 - 9 = Menu selection, with preview, identical to above.			

5.12 Detailed status: System

Table 5.12 shows the complete view for detailed status under the submenu **System**.

Table 5.12

Submenu	Submenu	Submenu	Submenu	Setting / Value	Comment		
EC 541 version	Detailed status	EC 541 version		0.01 [Unitless]	Status value		
		Option		1 [Unitless]	Status value		
		Hardware version		1 [Unitless]	Status value		
		Revision		[Text String]	Status value		
		Src timestamp:		[Text String]	Status value		
		SW build information	Module		[Text String]	Status value	
			Status		[Text String]	Status value	
			Comp.Ver: Build number:		[Text String]	Status value	
			Src timestamp:		[Text String]	Status value	
						Menu selection, with preview, identical to above.	
						Menu selection, with preview, identical to above.	
						Menu selection, with preview, identical to above.	
		EC 541 version	I/O module SW versions	CA 811		0.01 [Unitless]	Status value
				CA 821		0.01 [Unitless]	Status value
CA 831				0.01 [Unitless]	Status value		
CA 832				0.01 [Unitless]	Status value		

Submenu	Submenu	Submenu	Submenu	Setting / Value	Comment
EC 541 version	I/O module SW versions	CA 841		0.01 [Unitless]	Status value
		CA 861		0.01 [Unitless]	Status value
	I/O module HW versions	CA 811		1 [Unitless]	Status value
		CA 821		1 [Unitless]	Status value
		CA 831		1 [Unitless]	Status value
		CA 832		1 [Unitless]	Status value
		CA 841		1 [Unitless]	Status value
		CA 861		1 [Unitless]	Status value
Supply voltage			0.1 V DC	Status value	
PCB temperature			1 °C, 1 °F	Status value	
Remote config. blocked			NO, YES	Status value	
SD card ready			NO, YES	Status value	
System time			[Text String]	Status value	
Power monitor	Current			0.1 A	Status value
	Line current L1			0.1 A	Status value
	Line current L2			0.1 A	Status value
	Line current L3			0.1 A	Status value
	Average LN voltage			0.1 V	Status value
	Line voltage L1			0.1 V	Status value
	Line voltage L2			0.1 V	Status value
	Line voltage L3			0.1 V	Status value
	Average LL voltage			0.1 V	Status value
	L1-L2 voltage			0.1 V	Status value
	L2-L3 voltage			0.1 V	Status value
	L3-L1 voltage			0.1 V	Status value
	Power			0.1 kW	Status value
	Current frequency			0.01 Hz	Status value
Power factor			0.01 [Unitless]	Status value	
Power on time	Total			1 s, displayed as h:m:s	Setting, System Password
	Today			1 s, displayed as h:m:s	Setting, System Password
	Yesterday			1 s, displayed as h:m:s	Setting, System Password
Number of power on (boot)	Total			1 [Unitless]	Setting, System Password
	Today			1 [Unitless]	Setting, System Password
	Yesterday			1 [Unitless]	Setting, System Password

5.13 Detailed status: Pump pit

Table 5.13 shows the complete view for detailed status under the submenu **Pump pit**.

Table 5.13

Submenu	Submenu	Submenu	Setting / Value	Comment
Pit level			0.01 m, 0.01 ft	Status value
Pit volume			1 l, 1 gal	Status value
Pumped volume	Total		0.1 m3, 1 gal	Setting, System Password
	Today		0.1 m3, 1 gal	Setting, System Password
	Yesterday		0.1 m3, 1 gal	Setting, System Password
Energy consumption	Total		0.1 kWh	Setting, System Password
	Today		0.1 kWh	Setting, System Password
	Yesterday		0.1 kWh	Setting, System Password

Submenu	Submenu	Submenu	Setting / Value	Comment	
Pit efficiency	Average		0.001 kWh/m3, 1 kWh/Mgal	Setting, System Password	
	Today		0.001 kWh/m3, 1 kWh/Mgal	Setting, System Password	
	Yesterday		0.001 kWh/m3, 1 kWh/Mgal	Setting, System Password	
All pumps run #	Total		1 [Unitless]	Setting, System Password	
	Today		1 [Unitless]	Setting, System Password	
	Yesterday		1 [Unitless]	Setting, System Password	
All pumps run time	Total		1 s, displayed as h:m:s	Setting, System Password	
	Today		1 s, displayed as h:m:s	Setting, System Password	
	Yesterday		1 s, displayed as h:m:s	Setting, System Password	
Pit overflow	Overflow		NO, YES	Status value	
		Overflow level	1 mm, 0.01 in	Status value	
		Overflow flow	0.1 l/s, 1 GPM	Status value	
	Overflow time	Total		1 s, displayed as h:m:s	Setting, System Password
		Today		1 s, displayed as h:m:s	Setting, System Password
		Yesterday		1 s, displayed as h:m:s	Setting, System Password
	Overflow volume	Total		0.1 m3, 1 gal	Setting, System Password
		Today		0.1 m3, 1 gal	Setting, System Password
		Yesterday		0.1 m3, 1 gal	Setting, System Password
	No. of overflows	Total		1 [Unitless]	Setting, System Password
		Today		1 [Unitless]	Setting, System Password
		Yesterday		1 [Unitless]	Setting, System Password
Main pwr. mon.			NO, YES	Status value	
Secondary pit level			0.01 m, 0.01 ft	Status value	
Pit level difference			0.01 m, 0.01 ft	Status value	
Pump pit valve	Valve state		Closed, Open	Status value	
	Open detect		NO, YES	Status value	
	Close detect		NO, YES	Status value	
Drain pump	Drain pump float		OFF, ON	Status value	
	Terminal I/O status		OFF, ON	Status value	
	Run indication		NO, YES	Status value	
	Fallen motor protect		NO, YES	Status value	
	High temperature		NO, YES	Status value	
	Leakage		NO, YES	Status value	
	Externally blocked		NO, YES	Status value	
	Running time	Total		1 s, displayed as h:m:s	Setting, System Password
		Today		1 s, displayed as h:m:s	Setting, System Password
		Yesterday		1 s, displayed as h:m:s	Setting, System Password
	Number of starts	Total		1 [Unitless]	Setting, System Password
		Today		1 [Unitless]	Setting, System Password
Yesterday			1 [Unitless]	Setting, System Password	
Mixer	Terminal I/O status		OFF, ON	Status value	
	Run indication		NO, YES	Status value	
	Fallen motor protect		NO, YES	Status value	
	High temperature		NO, YES	Status value	
	Leakage		NO, YES	Status value	
	Externally blocked		NO, YES	Status value	
	Running time	Total		1 s, displayed as h:m:s	Setting, System Password
		Today		1 s, displayed as h:m:s	Setting, System Password
		Yesterday		1 s, displayed as h:m:s	Setting, System Password
	Number of starts	Total		1 [Unitless]	Setting, System Password
Mixer	Number of starts	Today	1 [Unitless]	Setting, System Password	
	Number of starts	Yesterday	1 [Unitless]	Setting, System Password	
Cleaner	Terminal I/O status		OFF, ON	Status value	

5.14 Detailed status: Pumps

Table 5.14 shows the complete view for detailed status under the submenu **Pumps**.

Table 5.14

Submenu	Submenu	Submenu	Submenu	Setting / Value	Comment		
Pump1	Tag name			[Text String]	Status value		
	Pump control			OFF, ON	Status value		
	Run indication			OFF, Ready to run, Running, Error run, Blocked, Error blocked, Pump reversing	Status value		
	State of M-0-A switch			MANUAL, Pump not in auto, AUTO	Status value		
	Pump fail			NO, YES	Status value		
	Pump exercising			NO, YES	Status value		
	Reverse			NO, YES	Status value		
	Reverse attempt cnt			1 [Unitless]	Status value		
	Reverse status			-OK-, Timer blocked, !NOT DEFINED TEXT!	Status value		
	Leakage	Leakage			NO, YES	Status value	
		Generic			NO, YES	Status value	
		Oil chamber			NO, YES	Status value	
		Motor housing			NO, YES	Status value	
		Electr. con. box			NO, YES	Status value	
	Temperature	Temperature			NO, YES	Status value	
		Generic			0.1 °C, 0.1 °F	Status value	
		Stator L1			0.1 °C, 0.1 °F	Status value	
		Stator L2			0.1 °C, 0.1 °F	Status value	
		Stator L3			0.1 °C, 0.1 °F	Status value	
		Upper bearing			0.1 °C, 0.1 °F	Status value	
	Lower bearing			0.1 °C, 0.1 °F	Status value		
	Vibration				0.1 mm/s ² , 0.01 in/h	Status value	
	Best efficiency point	Filtered effic. index			[User defined Unit]	Status value	
		Last raw effic. index			[User defined Unit]	Status value	
		Drive start ramp			1 s	Status value	
		Energy efficiency			0.0001 kWh/m ³ , 0.0001 kWh/Mgal	Status value	
		BEP frequency			0.01 Hz	Setting, System Password	
		BEP last step direction			-Decrease-, -Increase-, Retune	Setting, System Password	
		BEP step			0.01 Hz	Setting, System Password	
		BEP override	Pump at max. freq.			NO, YES	Status value
			Pump start counter			NO, YES	Status value
			All pumps running			NO, YES	Status value
	High level alarm				NO, YES	Status value	
	Pump valve	Valve state			Closed, Open	Status value	
		Open detect			NO, YES	Status value	
		Close detect			NO, YES	Status value	
	Logs	Running time	Total		1 s, displayed as h:m:s	Setting, System Password	
			Today		1 s, displayed as h:m:s	Setting, System Password	
			Yesterday		1 s, displayed as h:m:s	Setting, System Password	

Submenu	Submenu	Submenu	Submenu	Setting / Value	Comment		
Pump1	Logs	Number of starts	Total	1 [Unitless]	Setting, System Password		
			Today	1 [Unitless]	Setting, System Password		
			Yesterday	1 [Unitless]	Setting, System Password		
		Energy consumption	Total	0.1 kWh	Setting, System Password		
			Today	0.1 kWh	Setting, System Password		
			Yesterday	0.1 kWh	Setting, System Password		
		Pump efficiency	Average	0.001 kWh/m3, 1 kWh/Mgal	Setting, System Password		
			Today	0.001 kWh/m3, 1 kWh/Mgal	Setting, System Password		
			Yesterday	0.001 kWh/m3, 1 kWh/Mgal	Setting, System Password		
		Pumped volume	Total	1 l, 0.1 gal	Setting, System Password		
			Today	1 l, 0.1 gal	Setting, System Password		
			Yesterday	1 l, 0.1 gal	Setting, System Password		
		Pump capacity	Reference head	0.01 m, 0.01 ft	Status value		
			Today	0.1 l/s, 1 GPM	Setting, System Password		
			Yesterday	0.1 l/s, 1 GPM	Setting, System Password		
		Pwr.mon.	Pwr. mon.	Connected		-Not connected-, -Connected-	Status value
				Com. error		-OK-, -Error-	Status value
			Status	Current	0.1 A	Status value	
	Line current L1			0.1 A	Status value		
	Line current L2			0.1 A	Status value		
	Line current L3			0.1 A	Status value		
	Average LN voltage			0.1 V	Status value		
	Line voltage L1			0.1 V	Status value		
	Line voltage L2			0.1 V	Status value		
	Line voltage L3			0.1 V	Status value		
	Average LL voltage			0.1 V	Status value		
	L1-L2 voltage			0.1 V	Status value		
	L2-L3 voltage			0.1 V	Status value		
	L3-L1 voltage			0.1 V	Status value		
	Power			0.1 kW	Status value		
	Current frequency			0.01 Hz	Status value		
	Power factor			0.01 [Unitless]	Status value		
	M Drive			M Drive	M Drive Connected		-Not connected-, -Connected-
		M Drive error			-OK-, -Error-	Status value	
		M Drive Com. error			-OK-, -Error-	Status value	
		Drive status	M Drive not ready	OFF, ON	Status value		
			Drive status	OFF, Running, Tune in, Fault, Unknown state	Status value		
			Current frequency	0.01 Hz	Status value		
			Rotation speed	1 rpm	Status value		
			Motor voltage	0.1 V	Status value		
			Motor power	0.1 kW	Status value		
			Current	0.1 A	Status value		

Submenu	Submenu	Submenu	Submenu	Setting / Value	Comment
Pump1	M.Drive	Drive status	Torque Nm	1 Nm, 1 lbf.ft	Status value
			Torque %	0.1 %	Status value
Pump 2 - 6 = Menu selection, identical to above.					

5.15 Detailed status: PID regulator

Table 5.15 shows the complete view for detailed status under the submenu **PID regulator**.

Table 5.15

Submenu	Setting / Value	Comment
Output flags	AUTO, MANUAL, Blocked	Setting, Operator Password
Setpoint flags	Internal, External	Setting, Operator Password
Process value	0.01 m, 0.01 ft	Status value
Current setpoint	0.01 m, 0.01 ft	Setting, Operator Password
Output signal	0.1 %	Setting, Operator Password

5.16 Detailed status: Clock functions

Table 5.16 shows the complete view for detailed status under the submenu **Clock functions**.

Table 5.16

Submenu	Submenu	Submenu	Submenu	Setting / Value	Comment	
Time relays	Time relay 1	Status		OFF, ON	Status value	
		Time until next event		1 s, displayed as h:m:s	Status value	
		Active		OFF, ON	Status value	
		Sequence 1	Status		OFF, ON	Status value
			Time until next event		1 s, displayed as h:m:s	Status value
		Sequence 2			Menu selection, with preview, identical to above.	
		Sequence 3			Menu selection, with preview, identical to above.	
	Sequence 4			Menu selection, with preview, identical to above.		
	Time relay 2				Menu selection, with preview, identical to above.	
	Time relay 3				Menu selection, with preview, identical to above.	
	Time relay 4				Menu selection, with preview, identical to above.	
	Time relay 5				Menu selection, with preview, identical to above.	
	Time relay 6				Menu selection, with preview, identical to above.	
	Time relay 7				Menu selection, with preview, identical to above.	
	Time relay 8				Menu selection, with preview, identical to above.	
Count down timers	Count down timer 1	Output signal		OFF, ON	Status value	
		Status		OFF, ON, Manual off, Repet. expired (retrigger)	Status value	
		Manual control		AUTO, ON, OFF	Setting, Operator Password	
		Repetition(s)		1 [Unitless]	Status value	
		Delay time		1 s, displayed as h:m:s	Status value	
Count down timer 2 - 12 = Menu selection, with preview, identical to above.						

5.17 Detailed status: Pulse channels

Table 5.17 shows the complete view for detailed status under the submenu **Pulse channels**.

Table 5.17

Submenu	Submenu	Submenu	Setting / Value	Comment	
Pulse ch. 1	Function		Precipitation, Energy, Flow	Status value	
	One or none of lines below, depending on other settings.				
	Current value		0.1 l/s/ha, 0.01 in/h	Status value	
	Current value		0.1 kW	Status value	
	Current value		0.1 m ³ /h, 1 GPM	Status value	
	One or none of lines below, depending on other settings.				
	Accumulated values	Total		0.1 mm, 0.01 in	Setting, System Password
		Today		0.1 mm, 0.01 in	Setting, System Password
		Yesterday		0.1 mm, 0.01 in	Setting, System Password
	Accumulated values	Total		0.1 kWh	Setting, System Password
		Today		0.1 kWh	Setting, System Password
		Yesterday		0.1 kWh	Setting, System Password
	Accumulated values	Total		0.1 m ³ , 0.1 gal	Setting, System Password
		Today		0.1 m ³ , 0.1 gal	Setting, System Password
		Yesterday		0.1 m ³ , 0.1 gal	Setting, System Password
	Pulse ch. 2 - 4 = Menu selection, with preview, identical to above.				

5.18 Detailed status: Inputs and outputs

Table 5.18 shows the complete view for detailed status under the submenu **Inputs and outputs**.

Table 5.18

Submenu	Submenu	Submenu	Submenu	Setting / Value	Comment		
Analog inputs	Module 1	Module 1		-Not connected-, -Reconnecting-, -Not connected-, -Connected-, -Error-, -Error-, -Not connected-, CAN ID error, CAN ID error	Status value		
			Signal function	OFF, Pit level, Motor current, Outlet pressure, Vibrations, Outflow meter, Motor temperature, Secondary pit level, Free choice	Status value		
		AI1	One or none of lines below, depending on port function.				
			Current value		0.1 A	Status value	
			Current value		0.1 bar, 0.1 PSI	Status value	
			Current value		0.1 mm/s ² , 0.01 in/h	Status value	
			Current value		0.1 l/s, 1 GPM	Status value	
			Current value		0.1 °C, 0.1 °F	Status value	
			Current value		0.01 m, 0.01 ft	Status value	
			Current value		[User defined Unit]	Status value	
			One or none of lines below, depending on port function.				
			Object		Pump pit, Pump 1, Pump 2, Pump 3, Pump 4, Pump 5, Pump 6	Status value	
		Object		Pump 1, Pump 2, Pump 3, Pump 4, Pump 5, Pump 6	Status value		
		Designation		[Text String]	Status value		

Submenu	Submenu	Submenu	Submenu	Setting / Value	Comment
Analog inputs	Module 1	AI1	One or none of lines below, depending on port function.		
			Measure point	Generic, Stator L1, Stator L2, Stator L3, Upper bearing, Lower bearing	Status value
			Current	0.01 mA	Status value
		AI2 - AI6 = Menu selection, with preview, identical to above.			
Module 2 - 9 = Menu selection, with preview, identical to above.					
RTD temp. inputs	Module 1	Module 1		-Not connected-, -Reconnecting-, -Not connected-, -Connected-, -Error-, -Error-, -Not connected-, CAN ID error, CAN ID error	Status value
			Signal function	OFF, Motor temperature, Free choice	Status value
		RTD1	One or none of lines below, depending on port function.		
			Object	Pump 1, Pump 2, Pump 3, Pump 4, Pump 5, Pump 6	Status value
			One or none of lines below, depending on port function.		
			Measure point	Generic, Stator L1, Stator L2, Stator L3, Upper bearing, Lower bearing	Status value
			Designation	[Text String]	Status value
			One or none of lines below, depending on port function.		
			Current value	0.1 °C, 0.1 °F	Status value
		Current value	-OK-, -Tripped-	Status value	
		RTD2 - RTD6 = Menu selection, with preview, identical to above.			
Module 2 - 9 = Menu selection, with preview, identical to above.					
Analog outputs	Module 1	Module 1		-Not connected-, -Reconnecting-, -Not connected-, -Connected-, -Error-, -Error-, -Not connected-, CAN ID error, CAN ID error	Status value
Analog outputs	Module 1	AO1	Signal function	OFF, Pit level, Pit inflow, Pit outflow, Pit overflow, Pulse channel 1, Pulse channel 2, Pulse channel 3, Pulse channel 4, PID control output, Data register, Data register 2 compl., Set freq. P1, Set freq. P2, Set freq. P3, Set freq. P4, Set freq. P5, Set freq. P6	Status value
				Current value	0.01 mA
		AO2 - AO6 = Menu selection, with preview, identical to above.			
Module 2 - 9 = Menu selection, with preview, identical to above.					

Submenu	Submenu	Submenu	Submenu	Setting / Value	Comment
Digital inputs	Local at controller	D11	Signal function	OFF, Run indication, Manual start, Set manual, Set auto, Start float, Pump failure, Motor protector, High motor temp. pump, Leakage pump, Stop float, Low level float, Overflow sensor, High level float, Start float drain pump, Local mode, Alarm reset, Power fail, DI pulse channel 1-4, Block PID controller, Alarm input, Block operation, Leakage mixer-drain pump, High temp. mixer-drain p., Emergency power mode, Block remote data, Ackn. pump alarms, Valve open, Valve close	Status value
			One or none of lines below, depending on other settings.		
			Pulses ch1	1 [Unitless]	Status value
			Pulses ch2	1 [Unitless]	Status value
			Pulses ch3	1 [Unitless]	Status value
			Pulses ch4	1 [Unitless]	Status value
			Status	-OFF-, -ON-	Status value
			One or none of lines below, depending on other settings.		
			Object	Pump 1, Pump 2, Pump 3, Pump 4, Pump 5, Pump 6	Status value
			Object	Pulse channel 1, Pulse channel 2, Pulse channel 3, Pulse channel 4	Status value
			Object	Pump 1, Pump 2, Pump 3, Pump 4, Pump 5, Pump 6, Mixer, Drain pump, All	Status value
			Object	Mixer, Drain pump	Status value
			Allow set clock	NO, YES	Status value
			Object	Pump 1, Pump 2, Pump 3, Pump 4, Pump 5, Pump 6, All	Status value
			Object	Pump 1, Pump 2, Pump 3, Pump 4, Pump 5, Pump 6, Pump pit	Status value
			D11 One or none of lines below, depending on port function.		
			Measure point	Generic, Stator L1, Stator L2, Stator L3, Upper bearing, Lower bearing	Status value
			Measure point	Generic, Oil chamber, Motor housing, Electr. con. box	Status value
			Normally open/closed	NO input terminal, NC input terminal, True IO number, Inv. IO number	Status value
			D12 - D14 = Menu selection, with preview, identical to above.		

Submenu	Submenu	Submenu	Submenu	Setting / Value	Comment	
Digital inputs	Module 1	Module 1		-Not connected-, -Reconnecting-, -Not connected-, -Connected-, -Error-, -Error-, -Not connected-, CAN ID error, CAN ID error	Status value	
			Signal function	OFF, Run indication, Manual start, Set manual, Set auto, Start float, Pump failure, Motor protector, High motor temp. pump, Leakage pump, Stop float, Low level float, Overflow sensor, High level float, Start float drain pump, Local mode, Alarm reset, Power fail, DI pulse channel 1-4, Block PID controller, Alarm input, Block operation, Leakage mixer- drain pump, High temp. mixer-drain p., Emergency power mode, Block remote data, Ackn. pump alarms, Valve open, Valve close	Status value	
				One or none of lines below, depending on port function.		
				Pulses ch1	1 [Unitless]	Status value
				Pulses ch2	1 [Unitless]	Status value
				Pulses ch3	1 [Unitless]	Status value
				Pulses ch4	1 [Unitless]	Status value
				Status	-OFF-, -ON-	Status value
				One or none of lines below, depending on port function.		
				Object	Pump 1, Pump 2, Pump 3, Pump 4, Pump 5, Pump 6	Status value
				Object	Pulse channel 1, Pulse channel 2, Pulse channel 3, Pulse channel 4	Status value
				Object	Pump 1, Pump 2, Pump 3, Pump 4, Pump 5, Pump 6, Mixer, Drain pump, All	Status value
				Object	Mixer, Drain pump	Status value
				Allow set clock	NO, YES	Status value
				Object	Pump 1, Pump 2, Pump 3, Pump 4, Pump 5, Pump 6, All	Status value
				Object	Pump 1, Pump 2, Pump 3, Pump 4, Pump 5, Pump 6, Pump pit	Status value
				One or none of lines below, depending on port function.		
				Measure point	Generic, Stator L1, Stator L2, Stator L3, Upper bearing, Lower bearing	Status value

Submenu	Submenu	Submenu	Submenu	Setting / Value	Comment	
Digital inputs	Module 1	DI1	Measure point	Generic, Oil chamber, Motor housing, Electr. con. box	Status value	
			Normally open/closed	NO input terminal, NC input terminal, True IO number, Inv. IO number	Status value	
		DI2 - DI12 = Menu selection, with preview, identical to above.				
Module 2 - 9 = Menu selection, with preview, identical to above.						
Digital outputs	Local at controller	DO1	Signal function	OFF, Pump control, Reset motor protector, Pump fail, Not enough pumps avail., One pump fail, Mixer control, Drain pump control, Cleaner control, Com. timeout pulse, Remote control, Personnel alarm, High level, Alarm alert, Not ackn. alarm, Active alarm, Pump reversing, Logic IO, Data register setpoint, Auto reset alert, Valve control, Valve open, Valve close, Time relay, Pulse timer	Status value	
			Status	-OFF-, -ON-	Status value	
			One or none of lines below, depending on port function.			
			Object	Pump 1, Pump 2, Pump 3, Pump 4, Pump 5, Pump 6, Mixer, Drain pump, All	Status value	
			Communication port	Modem port (RS232), RS485 port 1, RS485 port 2, USB port, GPRS data, Ethernet port (TCP/IP)	Status value	
			Object	B-Alarm, A-Alarm, All alarms	Status value	
			Object	Pump 1, Pump 2, Pump 3, Pump 4, Pump 5, Pump 6	Status value	
			Object	Pump 1, Pump 2, Pump 3, Pump 4, Pump 5, Pump 6, Pump pit	Status value	
	DO2 - DO4 = Menu selection, with preview, identical to above.					
		Module 1	Module 1		-Not connected-, -Reconnecting-, -Not connected-, -Connected-, -Error-, -Error-, -Not connected-, CAN ID error, CAN ID error	Status value

Submenu	Submenu	Submenu	Submenu	Setting / Value	Comment		
Digital outputs	Module 1	DO1	Signal function	OFF, Pump control, Reset motor protector, Pump fail, Not enough pumps avail., One pump fail, Mixer control, Drain pump control, Cleaner control, Com. timeout pulse, Remote control, Personnel alarm, High level, Alarm alert, Not ackn. alarm, Active alarm, Pump reversing, Logic IO, Data register setpoint, Auto reset alert, Valve control, Valve open, Valve close, Time relay, Pulse timer	Status value		
			Status	-OFF-, -ON-	Status value		
			One or none of lines below, depending on port function.				
			Object	Pump 1, Pump 2, Pump 3, Pump 4, Pump 5, Pump 6, Mixer, Drain pump, All	Status value		
			Communication port	Modem port (RS232), RS485 port 1, RS485 port 2, USB port, GPRS data, Ethernet port (TCP/IP)	Status value		
			Object	B-Alarm, A-Alarm, All alarms	Status value		
			Object	Pump 1, Pump 2, Pump 3, Pump 4, Pump 5, Pump 6	Status value		
			Object	Pump 1, Pump 2, Pump 3, Pump 4, Pump 5, Pump 6, Pump pit	Status value		
			DO2 - DO8 = Menu selection, with preview, identical to above.				
			Module 2 - 9 = Menu selection, with preview, identical to above.				
Leakage inputs	Module 1	Module 1		-Not connected-, -Reconnecting-, -Not connected-, -Connected-, -Error-, -Error-, -Not connected-, CAN ID error, CAN ID error	Status value		
		DI1	Signal function	OFF, Leakage pump, Leakage mixer-drain pump	Status value		
			Status	-OFF-, -ON-	Status value		
			One or none of lines below, depending on port function.				
			Object	Pump 1, Pump 2, Pump 3, Pump 4, Pump 5, Pump 6	Status value		
			Object	Mixer, Drain pump	Status value		
			One or none of lines below, depending on port function.				
			Measure point	Generic, Oil chamber, Motor housing, Electr. con. box	Status value		
			DI2 - DI 6 = Menu selection, with preview, identical to above.				
			Module 2 - 9 = Menu selection, with preview, identical to above.				

5.19 Detailed status: Communication

Table 5.19 shows the complete view for detailed status under the submenu **Communication**.

Table 5.19

Submenu	Submenu	Submenu	Setting / Value	Comment
USB port	Port status		[Graphical representation]	Status value
	Protocol ID		1 [Unitless]	Status value
	Application protocol		Modbus slave, Modbus master	Status value
	Protocol type		Modbus RTU, Modbus TCP	Status value
	No. OK messages		1 [Unitless]	Status value
	No. Error messages		1 [Unitless]	Status value
	No. Checksum errors		1 [Unitless]	Status value
Modem port (RS232)	Port status		[Graphical representation]	Status value
	Baud rate		None, 300, 600, 1200, 2400, 4800, 9600, 19200, 38400, 57600, 115200, 230400, 460800	Status value
	Parity		None, Odd, Even, Mark	Status value
	Protocol ID		1 [Unitless]	Status value
	Application protocol		GPRS Hayes enable, Transparent	Status value
	Protocol type		Modbus RTU, Modbus TCP	Status value
	No. OK messages		1 [Unitless]	Status value
	No. Error messages		1 [Unitless]	Status value
	No. Checksum errors		1 [Unitless]	Status value
	No. Overflows		1 [Unitless]	Status value
	No. Parity errors		1 [Unitless]	Status value
	No. Framing errors		1 [Unitless]	Status value
	No. Break		1 [Unitless]	Status value
RS485 port 1	Port status		[Graphical representation]	Status value
	Baud rate		None, 300, 600, 1200, 2400, 4800, 9600, 19200, 38400, 57600, 115200, 230400, 460800	Status value
	Parity		None, Odd, Even, Mark	Status value
	Protocol ID		1 [Unitless]	Status value
	Application protocol		Modbus slave, Modbus master	Status value
RS485 port 1	Protocol type		Modbus RTU, Modbus TCP	Status value
	No. OK messages		1 [Unitless]	Status value
	No. Error messages		1 [Unitless]	Status value
	No. Checksum errors		1 [Unitless]	Status value
	No. Overflows		1 [Unitless]	Status value
	No. Parity errors		1 [Unitless]	Status value
	No. Framing errors		1 [Unitless]	Status value
No. Break		1 [Unitless]	Status value	

Submenu	Submenu	Submenu	Setting / Value	Comment	
RS485 port 2	Port status		[Graphical representation]	Status value	
	Baud rate		None, 300, 600, 1200, 2400, 4800, 9600, 19200, 38400, 57600, 115200, 230400, 460800	Status value	
	Parity		None, Odd, Even, Mark	Status value	
RS485 port 2	Protocol ID		1 [Unitless]	Status value	
	Application protocol		Modbus slave, Modbus master	Status value	
	Protocol type		Modbus RTU, Modbus TCP	Status value	
	No. OK messages		1 [Unitless]	Status value	
	No. Error messages		1 [Unitless]	Status value	
	No. Checksum errors		1 [Unitless]	Status value	
	No. Overflows		1 [Unitless]	Status value	
	No. Parity errors		1 [Unitless]	Status value	
	No. Framing errors		1 [Unitless]	Status value	
	No. Break		1 [Unitless]	Status value	
Ethernet port (TCP/IP)	Port status		[Graphical representation]	Status value	
	Protocol ID		1 [Unitless]	Status value	
	Application protocol		Modbus slave, Modbus master	Status value	
	Protocol type		Modbus RTU, Modbus TCP	Status value	
	One or none of lines below, depending on other settings.				
	Set static IP	IP address		[Text String]	Status value
		Net Mask		[Text String]	Status value
		Gateway		[Text String]	Status value
		Port number		1 [Unitless]	Status value
	Show dynamic IP	IP address		[Text String]	Status value
		Net Mask		[Text String]	Status value
		Gateway		[Text String]	Status value
		Port number		1 [Unitless]	Status value
	MAC ID		[Text String]	Status value	
	No. OK messages		1 [Unitless]	Status value	
No. Error messages		1 [Unitless]	Status value		
No. Checksum errors		1 [Unitless]	Status value		
GPRS status	Port status		[Graphical representation]	Status value	
	Signal 0-31 (99=NA)		1 [Unitless]	Status value	
	Local IP address		[Text String]	Status value	
	Connect status		-Not connected-, -Reconnecting-, -Connected-, Force reconnect, -TCP Server waiting-	Setting, Operator Password	
	Protocol ID		1 [Unitless]	Status value	
GPRS status	Application protocol		Modbus slave, Modbus master	Status value	
	Protocol type		Modbus RTU, Modbus TCP	Status value	
	Status counters	Connect counter		1 [Unitless]	Status value
		No. OK messages		1 [Unitless]	Status value
		No. Error messages		1 [Unitless]	Status value
No. Checksum errors			1 [Unitless]	Status value	

Submenu	Submenu	Submenu	Setting / Value	Comment
IO Modules (CAN bus)	Online		1 [Unitless]	Status value
	No. Tx OK messages		1 [Unitless]	Status value
	No. Rx OK messages		1 [Unitless]	Status value
	No. Error messages		1 [Unitless]	Status value

5.20 Detailed status: Field bus modules (RS485)

Table 5.20 shows the complete view for detailed status under the submenu **Field bus modules (RS485)**.

Table 5.20

Submenu	Submenu	Submenu	Setting / Value	Comment
Main pwr. mon.	Pwr. mon. Connected		-Not connected-, -Connected-	Status value
	Pwr. mon. Com. error		-OK-, -Error-	Status value
	Status	Current	0.1 A	Status value
		Line current L1	0.1 A	Status value
		Line current L2	0.1 A	Status value
		Line current L3	0.1 A	Status value
		Average LN voltage	0.1 V	Status value
		Line voltage L1	0.1 V	Status value
		Line voltage L2	0.1 V	Status value
		Line voltage L3	0.1 V	Status value
		Average LL voltage	0.1 V	Status value
		L1-L2 voltage	0.1 V	Status value
		L2-L3 voltage	0.1 V	Status value
		L3-L1 voltage	0.1 V	Status value
		Power	0.1 kW	Status value
		Current frequency	0.01 Hz	Status value
Power factor	0.01 [Unitless]	Status value		
Pwr.mon.P1	Pwr. mon. Connected		-Not connected-, -Connected-	Status value
	Pwr. mon. Com. error		-OK-, -Error-	Status value
	Status	Current	0.1 A	Status value
		Line current L1	0.1 A	Status value
		Line current L2	0.1 A	Status value
		Line current L3	0.1 A	Status value
		Average LN voltage	0.1 V	Status value
		Line voltage L1	0.1 V	Status value
		Line voltage L2	0.1 V	Status value
		Line voltage L3	0.1 V	Status value
		Average LL voltage	0.1 V	Status value
		L1-L2 voltage	0.1 V	Status value
		L2-L3 voltage	0.1 V	Status value
		L3-L1 voltage	0.1 V	Status value
		Power	0.1 kW	Status value
		Current frequency	0.01 Hz	Status value
Power factor	0.01 [Unitless]	Status value		
Pwr.mon.P2 - P6 = Menu selection, with preview, identical to above.				

Submenu	Submenu	Submenu	Setting / Value	Comment	
M.Drive P1	M.Drive Connected		-Not connected-, -Connected-	Status value	
	M.Drive error		-OK-, -Error-	Status value	
	M.Drive Com. error		-OK-, -Error-	Status value	
	Drive status	M.Drive not ready		OFF, ON	Status value
		Drive status		OFF, Running, Tune in, Fault, Unknown state	Status value
		Current frequency		0.01 Hz	Status value
		Rotation speed		1 rpm	Status value
		Motor voltage		0.1 V	Status value
		Motor power		0.1 kW	Status value
		Current		0.1 A	Status value
		Torque Nm		1 Nm, 1 lbf.ft	Status value
Torque %		0.1 %	Status value		
M.Drive P2 - P6 = Menu selection, with preview, identical to above.					

5.21 Settings: System

Table 5.21 shows the complete list of **System settings**.

Table 5.21

Submenu	Submenu	Submenu	Setting / Value	Comment	
Select language			English, French, German, Spanish, Danish, Dutch, Italian, Norwegian, Polish, Portuguese (Brazil), Swedish, Turkish	Setting, Operator Password	
Station ID			1 [Unitless]	Setting, System Password	
Station name			[Text String]	Setting, System Password	
Date format			YYYY.MM.DD, DD.MM.YYYY, MM.DD.YYYY	Setting, System Password	
Set date			[Text String]	Setting, Operator Password	
Set time			[Text String]	Setting, Operator Password	
Select units			Metric units, U.S. units	Setting, System Password	
Main nominal voltage			1 V	Setting, System Password	
Main nominal frequency			1 Hz	Setting, System Password	
Ackn. all alarms w reg 333			NO, YES	Setting, System Password	
System Alarms	Power fail				
	High PCB temp. EC 541				
	Low supply voltage				
	Personnel alarm				
		Max. time to reset		1 min	Setting, System Password
	EC 541 time lost				
EC 541 power lost					
Graphical display	Backlight timeout		1 min	Setting, System Password	
	Backlight strength		1%	Setting, System Password	
	Touch screen sensitivity		1%	Setting, System Password	
	Calibrate touch screen		NO, YES	Setting, System Password	

Submenu	Submenu	Submenu	Setting / Value	Comment
Graphical display	Scaling 100%		0.01 m, 0.01 ft	Setting, System Password
	Show overflow outlet		OFF, ON	Setting, System Password
	Mixer		OFF, ON	Setting, System Password
	Start/stop levels		OFF, ON	Setting, System Password
	Header line source		AUTO, None, AI1, AI2, AI3, AI4, AI5, AI6	Setting, System Password
	AI Module		1, 2, 3, 4, 5, 6, 7, 8, 9	Setting, System Password
	Information pump1	Hide electrical current		OFF, ON
Temp. symb. override enable			NO, YES	Setting, System Password
Temp. symbol override I/O			1 [Unitless]	Setting, System Password
Leak. symb. override enable			NO, YES	Setting, System Password
Graphical display	Information pump1	Leak. symbol override I/O	1 [Unitless]	Setting, System Password
		Electr. symbol override en.	NO, YES	Setting, System Password
		Electr. symb. override I/O	1 [Unitless]	Setting, System Password
		Vibrat. symbol override en.	NO, YES	Setting, System Password
		Vibrat. symb. override I/O	1 [Unitless]	Setting, System Password
Information pump2 - pump6 = Menu selection, Identical to above.				
SD card settings	Auto load FW from SD card		Never, Ask if file found, Always if higher version	Setting, System Password
	Auto load cfg. from SD card		Never, Ask if file found, Always if file found	Setting, System Password
	Copy cfg. data to SD card		Ready, Configuration, Config. and reg. logs	Status value
	Copy event list to SD		Ready, To .txt file	Status value
	Copy AI log to SD card		Ready, Today's log data, All log data	Status value
	Copy AI log to SD daily		OFF, To .txt file, To .xls file	Setting, System Password
	Save crash log to SD		Ready, Last crash log, All crash logs	Status value
Change passcode	Operator		1 [Unitless]	Setting, Operator Password
	System		1 [Unitless]	Setting, System Password
History/alarm reset	All history log		Cancel, Reset	Status value
	All alarms		Cancel, Reset	Status value

5.22 Settings: Pump pit

Table 5.22 shows the complete list of **Pump pit settings**.

Table 5.22

Submenu	Submenu	Submenu	Setting / Value	Comment
Station flow	Measurement parameters	Calculate inflow	OFF, ON	Setting, System Password
		Pit shape	Rectangular, Conical	Setting, System Password
		Inflow calc. interval	1 s	Setting, System Password
		Flow compensation 2 pumps	1%	Setting, System Password
		Flow compensation 3 pumps	1%	Setting, System Password
		Flow compensation 4 pumps	1%	Setting, System Password
		Flow compensation 5 pumps	1%	Setting, System Password
		Flow compensation 6 pumps	1%	Setting, System Password
	Pit area	Level 0	0.01 m, 0.01 ft	Setting, System Password
		Area 0	0.01 m ² , 0.01 ft ²	Setting, System Password
		Level 1	0.01 m, 0.01 ft	Setting, System Password
		Area 1	0.01 m ² , 0.01 ft ²	Setting, System Password
		Level 2	0.01 m, 0.01 ft	Setting, System Password
		Area 2	0.01 m ² , 0.01 ft ²	Setting, System Password
		Level 3	0.01 m, 0.01 ft	Setting, System Password
		Area 3	0.01 m ² , 0.01 ft ²	Setting, System Password
		Level 4	0.01 m, 0.01 ft	Setting, System Password
		Area 4	0.01 m ² , 0.01 ft ²	Setting, System Password
		Level 5	0.01 m, 0.01 ft	Setting, System Password
Station flow	Pit area	Area 5	0.01 m ² , 0.01 ft ²	Setting, System Password
		Level 6	0.01 m, 0.01 ft	Setting, System Password
		Area 6	0.01 m ² , 0.01 ft ²	Setting, System Password
		Level 7	0.01 m, 0.01 ft	Setting, System Password
		Area 7	0.01 m ² , 0.01 ft ²	Setting, System Password
		Level 8	0.01 m, 0.01 ft	Setting, System Password
		Area 8	0.01 m ² , 0.01 ft ²	Setting, System Password
		Level 9	0.01 m, 0.01 ft	Setting, System Password
		Area 9	0.01 m ² , 0.01 ft ²	Setting, System Password
Overflow	Overflow detect		OFF, Overflow sensor, Level limit	Setting, System Password
	Overflow calculation		Exponent & constant, Lock on inflow	Setting, System Password
	High level limit		0.001 m, 0.001 ft	Setting, System Password
	Exponent 1		0.0001 [Unitless]	Setting, System Password
	Constant 1		0.0001 [Unitless]	Setting, System Password
	Exponent 2		0.0001 [Unitless]	Setting, System Password
	Constant 2		0.0001 [Unitless]	Setting, System Password

Submenu	Submenu	Submenu	Setting / Value	Comment
Pit alarms	High level			
	Low level			
	High float			
	Pit alarms	Block alarm high float	Never block, 1 pump running, 2 pumps running	Setting, System Password
	Low float			
	High inflow			
	Low inflow			
	Backup run			
	Remote block			
	High pressure			
	Low pressure			
	Overflow			
	Pressure block			
	High pit level difference			
	Emergency power mode			
	Sensor			
	To few pumps available			
	Drain pump			
	Leakage mixer			
	High temp. mixer			
	Leakage drain pump			
	High temp. drain pump			
	No run indic. drain pump			
	Motor prot. drain pump			
	No run indication mixer			
	Motor prot. mixer			
Motor prot. rst.drain/mix				
Pit valve error				
Pit valve open error				
Pit valve close error				
Pump pit valve	Pump open delay		1 s	Setting, System Password
	Pump close delay		1 s	Setting, System Password
	Max. time to open		1 s	Setting, System Password
	Max. time to close		1 s	Setting, System Password
	Max. time to reopen		1 s	Setting, System Password
	Close retry delay time		1 s	Setting, System Password
Cleaning control	Flush at:		At pump start, At pump stop	Setting, System Password
	Running time		1 s	Setting, System Password
	Start count interval		1 [Unitless]	Setting, System Password
Mixer control	Stop pump during mix		NO, YES	Setting, System Password
	Mixer time		1 s	Setting, System Password
	Start count interval		1 [Unitless]	Setting, System Password
	Timer interval		1 min, displayed as hh:mm	Setting, System Password
	Max. level		0.01 m, 0.01 ft	Setting, System Password
	Min. level		0.01 m, 0.01 ft	Setting, System Password
Mixer control	Select run indication		OFF, Digital inputs	Setting, System Password
Drain pump control	Start delay		1 s	Setting, System Password
	Stop delay		1 s	Setting, System Password
	Select run indication		OFF, Digital inputs	Setting, System Password

Submenu	Submenu	Submenu	Setting / Value	Comment	
Motor prot. auto reset	Pulse time		1 s	Setting, System Password	
	Delay time		1 s	Setting, System Password	
	Max. No. attempts		0, 1, 2, 3	Setting, System Password	
Level-sensor check	At high-level float		OFF, ON	Setting, System Password	
	Level at high float		0.01 m, 0.01 ft	Setting, System Password	
	Max. deviation +/-		0.01 m, 0.01 ft	Setting, System Password	
	At low-level float		OFF, ON	Setting, System Password	
	Level at low float		0.01 m, 0.01 ft	Setting, System Password	
	Max. deviation +/-		0.01 m, 0.01 ft	Setting, System Password	
	Level change check		OFF, ON	Setting, System Password	
	Level change time		1 s	Setting, System Password	
	Min. level change +/-		0.01 m, 0.01 ft	Setting, System Password	
Tariff control	Tariff control		OFF, ON	Setting, System Password	
	Lead time		1 min	Setting, System Password	
	Pump down level		0.01 m, 0.01 ft	Setting, System Password	
	Peak Monday	Peak time 1 ON		1 min, displayed as hh:mm	Setting, System Password
		Peak time 1 OFF		1 min, displayed as hh:mm	Setting, System Password
		Peak time 2 ON		1 min, displayed as hh:mm	Setting, System Password
		Peak time 2 OFF		1 min, displayed as hh:mm	Setting, System Password
	Peak Tuesday - Sunday = Menu selection, identical to above.				
Level above sea	Set level		0.01 m, 0.01 ft	Setting, System Password	

5.23 Settings: Pumps

Table 5.23 shows the complete list of **Pump settings**.

Table 5.23

Submenu	Submenu	Submenu	Submenu	Submenu	Setting / Value	Comment	
Common P1-P6	Log pump events				NO, YES	Setting, System Password	
	Pump exercising	Max. standstill time			1 min, displayed as hh:mm	Setting, System Password	
		Running time			1 s	Setting, System Password	
		Start if level >			0.01 m, 0.01 ft	Setting, System Password	
	Pump exercising	Start if level <			0.01 m, 0.01 ft	Setting, System Password	
		Exercise P1			NO, YES	Setting, System Password	
		Exercise P2			NO, YES	Setting, System Password	
		Exercise P3			NO, YES	Setting, System Password	
		Exercise P4			NO, YES	Setting, System Password	
		Exercise P5			NO, YES	Setting, System Password	
		Exercise P6			NO, YES	Setting, System Password	
	Pump reversing	Enable per pump	Reversing P1			NO, YES	Setting, System Password
			Reversing P2			NO, YES	Setting, System Password
			Reversing P3			NO, YES	Setting, System Password
			Reversing P4			NO, YES	Setting, System Password
			Reversing P5			NO, YES	Setting, System Password
			Reversing P6			NO, YES	Setting, System Password
		Start reverse delay				1 s	Setting, System Password
		Reverse run time				1 s	Setting, System Password
		Max. No. attempts				0, 1, 2, 3, 4, 5	Setting, System Password
		Max. attempts reset time				1 min	Setting, System Password
		Max. attempts block time				1 h	Setting, System Password
		Manual reverse reset				NO, YES	Setting, System Password
		Stop other pumps				NO, YES	Setting, System Password
		Pump relay when rev.				OFF, ON	Setting, System Password
		Rev. on pump fail				NO, YES	Setting, System Password
		Rev. on fallen m.prot.				NO, YES	Setting, System Password
		Rev. on overcurrent				NO, YES	Setting, System Password
		Rev. on low pump capacity				NO, YES	Setting, System Password
		After No. starts	After No. starts			NO, YES	Setting, System Password

Submenu	Submenu	Submenu	Submenu	Submenu	Setting / Value	Comment		
Common P1-P6	Pump reversing		Pump1		1 [Unitless]	Setting, System Password		
			Pump2		1 [Unitless]	Setting, System Password		
			Pump3		1 [Unitless]	Setting, System Password		
			Pump4		1 [Unitless]	Setting, System Password		
			Pump5		1 [Unitless]	Setting, System Password		
			Pump6		1 [Unitless]	Setting, System Password		
	Max. No. pumps running	Max. No. pumps running				1, 2, 3, 4, 5, 6	Setting, System Password	
		Emergency power mode	Max. No. pumps running			1, 2, 3, 4, 5, 6	Setting, System Password	
			Block P1 in emgcy.pwr. mode				NO, YES	Setting, System Password
			Block P2 in emgcy.pwr. mode				NO, YES	Setting, System Password
			Block P3 in emgcy.pwr. mode				NO, YES	Setting, System Password
			Block P4 in emgcy.pwr. mode				NO, YES	Setting, System Password
			Block P5 in emgcy.pwr. mode				NO, YES	Setting, System Password
	Block P6 in emgcy.pwr. mode				NO, YES	Setting, System Password		
	Min. no pumps available	Min. no pumps available				1, 2, 3, 4, 5, 6	Setting, System Password	
	Min. relay interval	Min. time				1 s	Setting, System Password	
	Pump alternation	Altern. function				OFF, Normal, Asymmetrical	Setting, System Password	
		Enable per pump		Pump1			NO, YES	Setting, System Password
				Pump2			NO, YES	Setting, System Password
				Pump3			NO, YES	Setting, System Password
				Pump4			NO, YES	Setting, System Password
				Pump5			NO, YES	Setting, System Password
				Pump6			NO, YES	Setting, System Password
		One or none of lines below, depending on other settings.						
		Alternation after					Each pump stop, All pumps stopped	Setting, System Password
		Run time ratio		Pump1			1%	Setting, System Password
			Pump2			1%	Setting, System Password	
			Pump3			1%	Setting, System Password	
			Pump4			1%	Setting, System Password	
	Pump5				1%	Setting, System Password		

Submenu	Submenu	Submenu	Submenu	Submenu	Setting / Value	Comment		
Common P1-P6	Pump alternation	Run time ratio	Pump6		1%	Setting, System Password		
		After cont. runtime			1 min, displayed as hh:mm	Setting, System Password		
	Pump blocking	Remote blocking	Remote blocking			OFF, ON	Setting, System Password	
			Block timeout			1 s	Setting, System Password	
			Active			NO, YES	Setting, No Password	
		Low-level float	Low-level float			OFF, ON	Setting, System Password	
	Pump blocking	Pressure blocking	Pressure blocking			OFF, ON	Setting, System Password	
		Pressure blocking	Block delay			1 s	Setting, System Password	
			Block pressure			0.1 bar, 0.1 PSI	Setting, System Password	
			Block timeout			1 s	Setting, System Password	
		Power	Phase missing				NO, YES	Setting, System Password
			Over voltage				NO, YES	Setting, System Password
			Under voltage				NO, YES	Setting, System Password
			Unbalanced voltage				NO, YES	Setting, System Password
		Pump pit valve	Pit valve error				NO, YES	Setting, System Password
			Pit valve open error				NO, YES	Setting, System Password
			Pit valve close error				NO, YES	Setting, System Password
		Manual rst. on hi pump temp				NO, YES	Setting, System Password	
		Pwr.mon. block off delay				1 s	Setting, System Password	
		Calc. pump capacity	Function				OFF, ON	Setting, System Password
	Min. level p.cap. calc.					0.01 m, 0.01 ft	Setting, System Password	
	Start delay					1 s	Setting, System Password	
	Calculation time					1 s	Setting, System Password	
	Stop delay					1 s	Setting, System Password	
	Static head					0.01 m, 0.01 ft	Setting, System Password	
	Press. sens. inlet offset					0.01 m, 0.01 ft	Setting, System Password	
	Max. level pump capac. calc.					0.01 m, 0.01 ft	Setting, System Password	
	No. pump starts to alarm					1 [Unitless]	Setting, System Password	
	Auto set warning thresh. @					1%	Setting, System Password	
	Auto set alarm thresh. @					1%	Setting, System Password	

Submenu	Submenu	Submenu	Submenu	Submenu	Setting / Value	Comment		
Common P1-P6	Start on fast change	Start on fast change			OFF, ON	Setting, System Password		
		Start level change			0.01 m, 0.01 ft	Setting, System Password		
		Per			1 min	Setting, System Password		
		Min. No. pumps running			0, 1, 2, 3, 4, 5, 6	Setting, System Password		
		Max. No. pumps running			0, 1, 2, 3, 4, 5, 6	Setting, System Password		
		Stop on fast change			OFF, ON	Setting, System Password		
		Stop level change			0.01 m, 0.01 ft	Setting, System Password		
	Per		Per			1 min	Setting, System Password	
			Min. No. pumps running			0, 1, 2, 3, 4, 5, 6	Setting, System Password	
			Max. No. pumps running			0, 1, 2, 3, 4, 5, 6	Setting, System Password	
	Backup running		Running time			1 s	Setting, System Password	
			Pump 1 backup start			OFF, ON	Setting, System Password	
			Pump 2 backup start			OFF, ON	Setting, System Password	
			Pump 3 backup start			OFF, ON	Setting, System Password	
			Pump 4 backup start			OFF, ON	Setting, System Password	
			Pump 5 backup start			OFF, ON	Setting, System Password	
			Pump 6 backup start			OFF, ON	Setting, System Password	
Pump1	Copy pump setup from				None, Pump 1, Pump 2, Pump 3, Pump 4, Pump 5, Pump 6, Default	Status value		
	Pump control	Type of pump control			Pump disabled, On/Off control, VFD manual speed, VFD PID control, VFD Best effic. point	Setting, System Password		
		Select run indication			Any discrete source, Output signal, Digital inputs, Motor current, Field bus modules (RS485)	Setting, System Password		
		Current threshold (if apl.)			0.1 A	Setting, System Password		
		Pwr.mon.	Slave ID			1 [Unitless]	Setting, System Password	
			Bus selection			RS485 port 1, RS485 port 2	Setting, System Password	
			Manufacturer			None, Accuenergy, Schneider, Lumel, Carlo Gavazzi	Setting, System Password	
			One or none of lines below, depending on manufacturer settings					
			Model			None, Acuvim II	Setting, System Password	
			Model			None, PM 710, PM 5110	Setting, System Password	

Submenu	Submenu	Submenu	Submenu	Submenu	Setting / Value	Comment	
Pump1	Pump control	Pwr.mon.	Model		None, ND 10	Setting, System Password	
			Model		None, EM210	Setting, System Password	
			Alarm com. error				
	Start/stop levels	Start level	Stop level			0.01 m, 0.01 ft	Setting, Operator Password
			Stop level			0.01 m, 0.01 ft	Setting, Operator Password
			Random start range+-			0.01 m, 0.01 ft	Setting, Operator Password
	Start/stop levels	Start level high tariff	Stop level high tariff			0.01 m, 0.01 ft	Setting, Operator Password
			Stop level high tariff			0.01 m, 0.01 ft	Setting, Operator Password
			Random start range+-			0.01 m, 0.01 ft	Setting, Operator Password
			Alternative stop level			OFF, ON	Setting, Operator Password
	Time settings	Threshold-on delay	Threshold-off delay			1 s	Setting, System Password
			Threshold-off delay			1 s	Setting, System Password
			Max. cont. runtime			1 min, displayed as hh:mm	Setting, System Password
	Pump curve (QH)	Point 1 head (max.)	Point 1 flow (min.)			0.01 m, 0.01 ft	Setting, System Password
			Point 1 flow (min.)			0.1 l/s, 1 GPM	Setting, System Password
			Point 2 head (mid.)			0.01 m, 0.01 ft	Setting, System Password
			Point 2 flow (mid.)			0.1 l/s, 1 GPM	Setting, System Password
			Point 3 head (min.)			0.01 m, 0.01 ft	Setting, System Password
			Point 3 flow (max.)			0.1 l/s, 1 GPM	Setting, System Password
			Total head			0.01 m, 0.01 ft	Setting, System Password
			Pump curve Q-H exponent			0.0001 [Unitless]	Status value
	Pump alarms	No run indication	Fallen motor prot.				
			Motor prot. reset error				
			Not in auto				
			DI pump error				
			Max. run time				
			Alarm blocked				
			Max. reverse attempts				
			Phase missing				
			Pump valve error				
Valve open error							
Valve close error							
Low pump capacity			Alarm				
			Warning				

Submenu	Submenu	Submenu	Submenu	Submenu	Setting / Value	Comment	
Pump1	Pump alarms	Low pump capacity	Auto-set low cap. threshold		Inactive, Trigger auto-set, Auto-set running	Setting, System Password	
			Auto-set calc. counter		1 [Unitless]	Setting, System Password	
			Auto sequence options		Inactive, Detect ramp-up time, Forced auto sequence, Both options	Setting, System Password	
			Pump cap. calc. start delay		1 s	Setting, System Password	
			High vibrations				
		Leakage	Generic				
			Oil chamber				
			Motor housing				
			Electr. con. box				
		High temperature	Generic				
			Stator L1				
			Stator L2				
			Stator L3				
			Upper bearing				
	Lower bearing						
	High motor current						
	Low motor current						
	Block pump on alarm	High temperature	Generic			NO, YES	Setting, System Password
			Stator L1			NO, YES	Setting, System Password
			Stator L2			NO, YES	Setting, System Password
			Stator L3			NO, YES	Setting, System Password
			Upper bearing			NO, YES	Setting, System Password
			Lower bearing			NO, YES	Setting, System Password
		Leakage	Generic			NO, YES	Setting, System Password
			Oil chamber			NO, YES	Setting, System Password
			Motor housing			NO, YES	Setting, System Password
			Electr. con. box			NO, YES	Setting, System Password
High motor current					NO, YES	Setting, System Password	
Fallen motor prot.					NO, YES	Setting, System Password	
No run indication					NO, YES	Setting, System Password	
DI pump error				NO, YES	Setting, System Password		
High vibrations				NO, YES	Setting, System Password		
Pump valve error				NO, YES	Setting, System Password		
Valve open error				NO, YES	Setting, System Password		
Valve close error				NO, YES	Setting, System Password		

Submenu	Submenu	Submenu	Submenu	Submenu	Setting / Value	Comment
Pump1	Hold pump on alarm	Temperature	Generic		NO, YES	Setting, System Password
			Stator L1		NO, YES	Setting, System Password
			Stator L2		NO, YES	Setting, System Password
			Stator L3		NO, YES	Setting, System Password
			Upper bearing		NO, YES	Setting, System Password
			Lower bearing		NO, YES	Setting, System Password
	Hold pump on alarm	Leakage	Generic		NO, YES	Setting, System Password
			Oil chamber		NO, YES	Setting, System Password
			Motor housing		NO, YES	Setting, System Password
			Electr. con. box		NO, YES	Setting, System Password
		Vibration			NO, YES	Setting, System Password
	Best efficiency point	Start at max., every x start			1 [Unitless]	Setting, System Password
		Max. freq. run time			1 s	Setting, System Password
		Max. freq. if all pump run			NO, YES	Setting, System Password
		All pumps max. freq. delay			1 s	Setting, System Password
		Max. freq. on hi lvi alarm			NO, YES	Setting, System Password
	Pump valve	Pump open delay			1 s	Setting, System Password
		Pump close delay			1 s	Setting, System Password
		Max. time to open			1 s	Setting, System Password
		Max. time to close			1 s	Setting, System Password
		Max. time to reopen			1 s	Setting, System Password
		Close retry delay time			1 s	Setting, System Password
	Tag name				[Text String]	Setting, System Password
Pump2 - Pump3 = Menu selection, Identical to above.						

5.24 Settings: Clock functions

Table 5.24 shows the complete list of **Clock functions settings**.

Table 5.24

Submenu	Submenu	Setting	Submenu	Submenu	Setting / Value	Comment		
Time relays	Time relay 1	Active			OFF, ON	Setting, System Password		
		Sequence 1	Interval base			OFF, Day, Week, Month-date, 1st week of month, 2nd week of month, 3rd week of month, 4th week of month, 5th week of month	Setting, System Password	
			One or none of lines below, depending on other settings.					
			Repeat every...			day, 2nd day, 3rd day, 4th day, 5th day, 6th day, 7th day	Setting, System Password	
			Repeat every...			week, 2nd week, 3rd week, 4th week, 5th week	Setting, System Password	
			Repeat every...	January			OFF, ON	Setting, System Password
				February			OFF, ON	Setting, System Password
				March			OFF, ON	Setting, System Password
				April			OFF, ON	Setting, System Password
				May			OFF, ON	Setting, System Password
				June			OFF, ON	Setting, System Password
				July			OFF, ON	Setting, System Password
				August			OFF, ON	Setting, System Password
				September			OFF, ON	Setting, System Password
				October			OFF, ON	Setting, System Password
				November			OFF, ON	Setting, System Password
				December			OFF, ON	Setting, System Password
			Repeat every...					Menu selection, identical to above.
			One or none of lines below, depending on other settings.					
			Turn on day(s)	Monday			OFF, ON	Setting, System Password
				Tuesday			OFF, ON	Setting, System Password
		Wednesday				OFF, ON	Setting, System Password	
		Thursday				OFF, ON	Setting, System Password	
		Friday				OFF, ON	Setting, System Password	
		Saturday				OFF, ON	Setting, System Password	
		Sunday				OFF, ON	Setting, System Password	

Submenu	Submenu	Setting	Submenu	Submenu	Setting / Value	Comment	
Time relays	Time relay 1	Sequence 1	Turn on day(s)		1 [Unitless]	Setting, System Password	
			Turn on day(s)			Menu selection, Identical to above.	
			Turn on time		1 s, displayed as h:m:s	Setting, System Password	
			Duration		1 d	Setting, System Password	
			Duration		1 s, displayed as h:m:s	Setting, System Password	
		Sequence 2 - 4 = Menu selection, with preview, identical to above.					
		Tag name				[Text String]	Setting, System Password
Time relay 2 - 8 = Menu selection, with preview, identical to above.							
Count down timers	Count down timer 1	Trigger source			OFF, DI on, DI off, IO on, IO off, Reg. not equal (!=), Reg. less than (<), Reg. less or equal to (<=), Reg. equal to (==), Reg. more or equal to (>=), Reg. more than (>)	Setting, System Password	
Count down timers	Count down timer 1	One or none of lines below, depending on other settings.					
		Module				1, 2, 3, 4, 5, 6, 7, 8, 9	Setting, System Password
		IO number				1 [Unitless]	Setting, System Password
		Data register				1 [Unitless]	Setting, System Password
		One or none of lines below, depending on other settings.					
		Signal source				1, 2, 3, 4, 5, 6, 7, 8, 9, 10, 11, 12	Setting, System Password
		Threshold value				1 [Unitless]	Setting, System Password
		Repetition(s)				Continuous, 1, 2, 3, 4, 5, 6, 7, 8, 9	Setting, System Password
		Duration				1 s, displayed as h:m:s	Setting, System Password
		Tag name				[Text String]	Setting, System Password
Count down timer 2 - 12 = Menu selection, with preview, identical to above.							

5.25 Settings: IO-bit controlled data

Table 5.25 shows the complete list of **IO-bit controlled data settings**.

Table 5.25

Submenu	Submenu	Setting / Value	Comment
IO controlled data 1	Register control	OFF, ON	Setting, System Password
	IO number	1 [Unitless]	Setting, System Password
	Controls data register	1 [Unitless]	Setting, System Password
	Source data when IO off (0)	Data value, Data register	Setting, System Password
	Data when IO off (0)	1 [Unitless]	Setting, System Password
	Source data when IO on (1)	Data value, Data register	Setting, System Password
	Data when IO on (1)	1 [Unitless]	Setting, System Password
IO controlled data 2 - 32 = Menu selection, with preview, identical to above.			

5.27 Settings: PID regulator

Table 5.27 shows the complete list of **PID regulator settings**.

Table 5.27

Submenu	Setting / Value	Comment
Extern setpoint input	OFF, AI1, AI2, AI3, AI4, AI5, AI6	Setting, System Password
AI Module	1, 2, 3, 4, 5, 6, 7, 8, 9	Setting, System Password
Setpoint tracking	NO, YES	Setting, System Password
Setpoint when start	Last, Setup start, External	Setting, System Password
Max. setpoint	0.01 m, 0.01 ft	Setting, System Password
Min. setpoint	0.01 m, 0.01 ft	Setting, System Password
Setpoint	0.01 m, 0.01 ft	Setting, System Password
Setpoint high tariff	0.01 m, 0.01 ft	Setting, System Password
Start setpoint	0.01 m, 0.01 ft	Setting, System Password
Output state when start	Last state, AUTO, MANUAL, Internally blocked	Setting, System Password
Output when blocked	Freeze output, Setup block signal	Setting, System Password
Block output	0.1 %	Setting, System Password
Max. output change	0.1 %/s	Setting, System Password
Max. output	0.1 %	Setting, System Password
Min. output	0.1 %	Setting, System Password
Start output	0.1 %	Setting, System Password
Direct/Reverse effect	Reverse, Direct	Setting, System Password
P-Band	0.001 [Unitless]	Setting, System Password
I-Time	0.01 s	Setting, System Password
D-Time	0.01 s	Setting, System Password
Zero deviation output	0.1 %	Setting, System Password
Calc. pump cap. @ max. speed	NO, YES	Setting, System Password
Min. speed	0.1 %	Setting, System Password
Locked speed pumping out	0.1 %	Setting, System Password
Lock speed delay	1 s	Setting, System Password

5.28 Settings: Pulse channels

Table 5.28 shows the complete list of **Pulse channel settings**.

Table 5.28

Submenu	Submenu	Setting / Value	Comment
Pulse ch. 1	Function	Precipitation, Energy, Flow	Setting, System Password
	One or none of lines below, depending on other settings.		
	1 Pulse	0.0001 mm, 0.0001 in	Setting, System Password
	1 Pulse	0.0001 kWh	Setting, System Password
	1 Pulse	0.0001 m ³ , 0.0001 gal	Setting, System Password
	One or none of lines below, depending on other settings.		
	Set high alarm		
	Set high alarm		
	Set high alarm		
	One or none of lines below, depending on other settings.		
	Set low alarm		
	Pulse ch. 2 - 4 = Menu selection, with preview, identical to above.		

5.29 Settings: Analog logging

Table 5.29 shows the complete list of **Analog logging settings**.

Table 5.29

Submenu	Submenu	Setting / Value	Comment	
Log channel 1	Log signal	OFF, Level pit, Inflow pit, Outflow, Overflow level, Overflow flow, Outlet pressure, Motor current, Pump capacity, Power factor, Temperature motor, Temp. stator wiring L1, Temp. stator wiring L2, Temp. stator wiring L3, Temp. upper bearing, Temp. lower bearing, Vibration, Main voltage, Main frequency, Free choice AI, Free choice RTD, Power supply, Pulse channel 1-4, PID controller output, Data register, Data register 2 compl., Set frequency, Actual frequency, Motor power, Motor voltage, Torque, Outflow meter, Total head, PCB temperature EC 541, BEP frequency, BEP efficiency, Mains power, Actual head, Secondary pit level, Pit level difference	Setting, System Password	
	Log function	Closed, Actual value, Average value, Min. value, Max. value	Setting, System Password	
	Log interval	1 min	Setting, System Password	
	One or none of lines below, depending on other settings.			
	Object	Pump pit, Pump 1, Pump 2, Pump 3, Pump 4, Pump 5, Pump 6	Setting, System Password	
	Analog input number (1-6)	1, 2, 3, 4, 5, 6	Setting, System Password	
	Object	Pulse channel 1, Pulse channel 2, Pulse channel 3, Pulse channel 4	Setting, System Password	
	Data register number	1 [Unitless]	Setting, System Password	
	Object	Pump 1, Pump 2, Pump 3, Pump 4, Pump 5, Pump 6	Setting, System Password	
	One or none of lines below, depending on other settings.			
AI Module	1, 2, 3, 4, 5, 6, 7, 8, 9	Setting, System Password		
Log channel 2 - 32 = Menu selection, with preview, identical to above.				

5.30 Settings: Inputs and outputs

Table 5.30 shows the complete list of **Inputs and output settings**.

Table 5.30

Submenu	Submenu	Submenu	Submenu	Submenu	Setting / Value	Comment	
Analog inputs	Module 1	Module 1			-Not connected-, -Reconnecting-, -Not connected-, -Connected-, -Error-, -Error-, -Not connected-, CAN ID error, CAN ID error	Status value	
			Signal function		OFF, Pit level, Motor current, Outlet pressure, Vibrations, Outflow meter, Motor temperature, Secondary pit level, Free choice	Setting, System Password	
	Module 1	AI1	One or none of lines below, depending on port function.				
			Measure point			Generic, Stator L1, Stator L2, Stator L3, Upper bearing, Lower bearing	Setting, System Password
			One or none of lines below, depending on port function.				
			Object			Pump pit, Pump 1, Pump 2, Pump 3, Pump 4, Pump 5, Pump 6	Setting, System Password
			Object			Pump 1, Pump 2, Pump 3, Pump 4, Pump 5, Pump 6	Setting, System Password
	One or none of lines below, depending on port function.						

Submenu	Submenu	Submenu	Submenu	Submenu	Setting / Value	Comment
Analog inputs	Module 1	AI1	Settings	Scaling 0%	0.01 m, 0.01 ft	Setting, System Password
				Scaling 100%	0.01 m, 0.01 ft	Setting, System Password
				Filter constant	1 s	Setting, System Password
				Zero offset	0.01 m, 0.01 ft	Setting, System Password
				Dead band	0.1 %	Setting, System Password
				Set sensor/ cable alarm		
				Scaling 0%	0.1 A	Setting, System Password
				Scaling 100%	0.1 A	Setting, System Password
				Filter constant	1 s	Setting, System Password
				Zero offset	0.1 A	Setting, System Password
				Dead band	0.1 %	Setting, System Password
				Set sensor/ cable alarm		
				Scaling 0%	0.1 bar, 0.1 PSI	Setting, System Password
				Scaling 100%	0.1 bar, 0.1 PSI	Setting, System Password
				Filter constant	1 s	Setting, System Password
				Zero offset	0.1 bar, 0.1 PSI	Setting, System Password
				Dead band	0.1 %	Setting, System Password
				Set sensor/ cable alarm		
				Scaling 0%	0.1 mm/s ² , 0.01 in/h	Setting, System Password
				Scaling 100%	0.1 mm/s ² , 0.01 in/h	Setting, System Password
				Filter constant	1 s	Setting, System Password
				Zero offset	0.1 mm/s ² , 0.01 in/h	Setting, System Password
				Dead band	0.1 %	Setting, System Password
				Set sensor/ cable alarm		
				Scaling 0%	0.1 l/s, 1 GPM	Setting, System Password
				Scaling 100%	0.1 l/s, 1 GPM	Setting, System Password
				Filter constant	1 s	Setting, System Password
				Zero offset	0.1 l/s, 1 GPM	Setting, System Password
				Dead band	0.1 %	Setting, System Password
				Set sensor/ cable alarm		
				Scaling 0%	0.1 °C, 0.1 °F	Setting, System Password
				Scaling 100%	0.1 °C, 0.1 °F	Setting, System Password
				Filter constant	1 s	Setting, System Password

Submenu	Submenu	Submenu	Submenu	Submenu	Setting / Value	Comment			
Analog inputs	Module 1	AI1	Settings	Zero offset	0.1 °C, 0.1 °F	Setting, System Password			
				Dead band	0.1 %	Setting, System Password			
				Set sensor/ cable alarm					
				Scaling 0%	0.01 m, 0.01 ft	Setting, System Password			
				Scaling 100%	0.01 m, 0.01 ft	Setting, System Password			
				Filter constant	1 s	Setting, System Password			
				Zero offset	0.01 m, 0.01 ft	Setting, System Password			
				Dead band	0.1 %	Setting, System Password			
				Set sensor/ cable alarm					
				Designation	[Text String]	Setting, System Password			
				No. of decimals	1 [Unitless]	Setting, System Password			
				Select units	[Text String]	Setting, System Password			
				Scaling 0%	[User defined Unit]	Setting, System Password			
				Scaling 100%	[User defined Unit]	Setting, System Password			
				Filter constant	1 s	Setting, System Password			
				Zero offset	[User defined Unit]	Setting, System Password			
				Dead band	0.1 %	Setting, System Password			
				Set high alarm					
				Set hi-high alarm					
				Set low alarm					
			Set low-low alarm						
			Set sensor/ cable alarm						
			One or none of lines below, depending on port function.						
			Current value		0.1 A	Status value			
			Current value		0.1 bar, 0.1 PSI	Status value			
			Current value		0.1 mm/s ² , 0.01 in/h	Status value			
			Current value		0.1 l/s, 1 GPM	Status value			
			Current value		0.1 °C, 0.1 °F	Status value			
			Current value		0.01 m, 0.01 ft	Status value			
			Current value		[User defined Unit]	Status value			
Current		0.01 mA	Status value						
AI2 - AI6 = Menu selection, with preview, identical to above.									
Module 2 - 9 = Menu selection, with preview, identical to above.									
RTD temp. inputs	Module 1	Module 1			-Not connected-, -Reconnecting-, -Not connected-, -Connected-, -Error-, -Error-, -Not connected-, CAN ID error, CAN ID error	Status value			
		RTD1	Signal function		OFF, Motor temperature, Free choice	Setting, System Password			
			Signal type		Pt100 (temp. sensor), PTC/ Bimetal switch	Setting, System Password			
		One or none of lines below, depending on port function.							

Submenu	Submenu	Submenu	Submenu	Submenu	Setting / Value	Comment		
RTD temp. inputs	Module 1	RTD1	Object		Pump 1, Pump 2, Pump 3, Pump 4, Pump 5, Pump 6	Setting, System Password		
			One or none of lines below, depending on port function.					
			Object		Generic, Stator L1, Stator L2, Stator L3, Upper bearing, Lower bearing	Setting, System Password		
			One or none of lines below, depending on other settings.					
			One or none of lines below, depending on port function.					
			Settings	Filter constant	1 s	Setting, System Password		
				Zero offset	0.1 °C, 0.1 °F	Setting, System Password		
				Set sensor/cable alarm				
				Designation	[Text String]	Setting, System Password		
				Filter constant	1 s	Setting, System Password		
				Zero offset	0.1 °C, 0.1 °F	Setting, System Password		
				Set high alarm				
				Set hi-high alarm				
				Set low alarm				
		Set sensor/cable alarm						
		One or none of lines below, depending on port function.						
		Settings	Designation	[Text String]	Setting, System Password			
		RTD1	One or none of lines below, depending on other settings.					
			Current value	0.1 °C, 0.1 °F	Status value			
			Current value	-OK-, -Tripped-	Status value			
		RTD2 - RTD6 = Menu selection, with preview, identical to above.						
		Module 2 - 9 = Menu selection, with preview, identical to above.						
		Analog outputs	Module 1	Module 1			-Not connected-, -Reconnecting-, -Not connected-, -Connected-, -Error-, -Error-, -Not connected-, CAN ID error, CAN ID error	Status value
AO1	Signal function					OFF, Pit level, Pit inflow, Pit outflow, Pit overflow, Pulse channel 1, Pulse channel 2, Pulse channel 3, Pulse channel 4, PID control output, Data register, Data register 2 compl., Set freq. P1, Set freq. P2, Set freq. P3, Set freq. P4, Set freq. P5, Set freq. P6	Setting, System Password	
	Current value			0.01 mA	Status value			
	Filter constant			1 s	Setting, System Password			
	One or none of lines below, depending on port function.							
	Settings			Scaling 0%	0.01 m, 0.01 ft	Setting, System Password		
				Scaling 100%	0.01 m, 0.01 ft	Setting, System Password		
				Scaling 0%	0.1 l/s, 1 GPM	Setting, System Password		
				Scaling 100%	0.1 l/s, 1 GPM	Setting, System Password		
				Scaling 0%	0.1 m ³ /h, 1 GPM	Setting, System Password		
				Scaling 100%	0.1 m ³ /h, 1 GPM	Setting, System Password		
	One or none of lines below, depending on other settings.							

Submenu	Submenu	Submenu	Submenu	Submenu	Setting / Value	Comment		
Analog outputs	Module 1	AO1	Settings	Scaling 0%	0.1 l/s/ha, 0.1 in/h	Setting, System Password		
				Scaling 100%	0.1 l/s/ha, 0.1 in/h	Setting, System Password		
				Scaling 0%	0.1 kW	Setting, System Password		
				Scaling 100%	0.1 kW	Setting, System Password		
				Scaling 0%	0.1 m3/h, 1 GPM	Setting, System Password		
				Scaling 100%	0.1 m3/h, 1 GPM	Setting, System Password		
				Set data register	1 [Unitless]	Setting, System Password		
				Scaling 0%	1 [Unitless]	Setting, System Password		
				Scaling 100%	1 [Unitless]	Setting, System Password		
				Set data register	1 [Unitless]	Setting, System Password		
				Scaling 0%	1 [Unitless]	Setting, System Password		
				Scaling 100%	1 [Unitless]	Setting, System Password		
				Scaling 0%	0.01 Hz	Setting, System Password		
				Scaling 100%	0.01 Hz	Setting, System Password		
AO2 - AO6 = Menu selection, with preview, identical to above.								
Module 2 - 9 = Menu selection, with preview, identical to above.								
Digital inputs	Local at controller	DI1	Signal function		OFF, Run indication, Manual start, Set manual, Set auto, Start float, Pump failure, Motor protector, High motor temp. pump, Leakage pump, Stop float, Low level float, Overflow sensor, High level float, Start float drain pump, Local mode, Alarm reset, Power fail, DI pulse channel 1-4, Block PID controller, Alarm input, Block operation, Leakage mixer-drain pump, High temp. mixer-drain p., Emergency power mode, Block remote data, Ackn. pump alarms, Valve open, Valve close	Setting, System Password		
				One or none of lines below, depending on port function.				
				One or none of lines below, depending on other settings.				
				Pulses ch1		1 [Unitless]	Status value	
				Pulses ch2		1 [Unitless]	Status value	
				Pulses ch3		1 [Unitless]	Status value	
				Pulses ch4		1 [Unitless]	Status value	
				Status		-OFF-, -ON-	Status value	
				One or none of lines below, depending on port function.				
				Measure point		Generic, Stator L1, Stator L2, Stator L3, Upper bearing, Lower bearing	Setting, System Password	
				Measure point		Generic, Oil chamber, Motor housing, Electr. con. box	Setting, System Password	
				One or none of lines below, depending on port function.				
				Object		Pump 1, Pump 2, Pump 3, Pump 4, Pump 5, Pump 6	Setting, System Password	
				Alarm reset delay		1 s	Setting, System Password	

Submenu	Submenu	Submenu	Submenu	Submenu	Setting / Value	Comment		
Digital inputs	Local at controller	DI1	Object		Pulse channel 1, Pulse channel 2, Pulse channel 3, Pulse channel 4	Setting, System Password		
			Alarm settings	Alarm text	[Text String]	Setting, System Password		
			Object		Pump 1, Pump 2, Pump 3, Pump 4, Pump 5, Pump 6, Mixer, Drain pump, All	Setting, System Password		
			Object		Mixer, Drain pump	Setting, No Password		
			Allow set clock		NO, YES	Setting, System Password		
			Object		Pump 1, Pump 2, Pump 3, Pump 4, Pump 5, Pump 6, All	Setting, System Password		
			Object		Pump 1, Pump 2, Pump 3, Pump 4, Pump 5, Pump 6, Pump pit	Setting, System Password		
			Signal source		NO input terminal, NC input terminal, True IO number, Inv. IO number	Setting, System Password		
			One or none of lines below, depending on other settings.					
			IO number		1 [Unitless]	Setting, System Password		
			Event trigger		OFF, ON	Setting, System Password		
	Local at controller	DI2 - DI4 = Menu selection, with preview, identical to above.						
	Module 1	Module 1	Module 1			-Not connected-, -Reconnecting-, -Not connected-, -Connected-, -Error-, -Error-, -Not connected-, CAN ID error, CAN ID error	Status value	
				Signal function		OFF, Run indication, Manual start, Set manual, Set auto, Start float, Pump failure, Motor protector, High motor temp. pump, Leakage pump, Stop float, Low level float, Overflow sensor, High level float, Start float drain pump, Local mode, Alarm reset, Power fail, DI pulse channel 1-4, Block PID controller, Alarm input, Block operation, Leakage mixer-drain pump, High temp. mixer-drain p., Emergency power mode, Block remote data, Ackn. pump alarms, Valve open, Valve close	Setting, System Password	
		One or none of lines below, depending on port function.						
		One or none of lines below, depending on other settings.						
		Pulses ch1		1 [Unitless]	Status value			
		Pulses ch2		1 [Unitless]	Status value			
		Pulses ch3		1 [Unitless]	Status value			
		Pulses ch4		1 [Unitless]	Status value			
		Status		-OFF-, -ON-	Status value			
		One or none of lines below, depending on port function.						
		Measure point		Generic, Stator L1, Stator L2, Stator L3, Upper bearing, Lower bearing	Setting, System Password			
Measure point			Generic, Oil chamber, Motor housing, Electr. con. box	Setting, System Password				
One or none of lines below, depending on port function.								
Object		Pump 1, Pump 2, Pump 3, Pump 4, Pump 5, Pump 6	Setting, System Password					
Alarm reset delay		1 s	Setting, System Password					

Submenu	Submenu	Submenu	Submenu	Submenu	Setting / Value	Comment			
Digital inputs	Module 1	DI1	Object		Pulse channel 1, Pulse channel 2, Pulse channel 3, Pulse channel 4	Setting, System Password			
			Alarm settings						
				Alarm text	[Text String]	Setting, System Password			
			Object		Pump 1, Pump 2, Pump 3, Pump 4, Pump 5, Pump 6, Mixer, Drain pump, All	Setting, System Password			
			Object		Mixer, Drain pump	Setting, No Password			
			Allow set clock		NO, YES	Setting, System Password			
			Object		Pump 1, Pump 2, Pump 3, Pump 4, Pump 5, Pump 6, All	Setting, System Password			
			Object		Pump 1, Pump 2, Pump 3, Pump 4, Pump 5, Pump 6, Pump pit	Setting, System Password			
			Signal source		NO input terminal, NC input terminal, True IO number, Inv. IO number	Setting, System Password			
			One or none of lines below, depending on other settings.						
			IO number		1 [Unitless]	Setting, System Password			
			Event trigger		OFF, ON	Setting, System Password			
			DI2 - DI12 = Menu selection, with preview, identical to above.						
Module 2 - 9 = Menu selection, with preview, identical to above.									
Digital outputs	Local at controller	DO1	Signal function		OFF, Pump control, Reset motor protector, Pump fail, Not enough pumps avail., One pump fail, Mixer control, Drain pump control, Cleaner control, Com. timeout pulse, Remote control, Personnel alarm, High level, Alarm alert, Not ackn. alarm, Active alarm, Pump reversing, Logic IO, Data register setpoint, Auto reset alert, Valve control, Valve open, Valve close, Time relay, Pulse timer	Setting, System Password			
			Status		-OFF-, -ON-	Status value			
			One or none of lines below, depending on port function.						
			Object		Pump 1, Pump 2, Pump 3, Pump 4, Pump 5, Pump 6, Mixer, Drain pump, All	Setting, System Password			
			Settings	Communication port		Modem port (RS232), RS485 port 1, RS485 port 2, USB port, GPRS data, Ethernet port (TCP/IP)	Setting, System Password		
				Pulse time		1 s	Setting, System Password		
				Communication timeout		1 s	Setting, System Password		
				Object		B-Alarm, A-Alarm, All alarms	Setting, System Password		
				Alert source		Unackn. alarms, Active alarms, Unackn. + active alarms	Setting, System Password		
				On time		1 s	Setting, System Password		
			Pause time		1 s	Setting, System Password			
			Object		B-Alarm, A-Alarm, All alarms	Setting, System Password			
			Object		Pump 1, Pump 2, Pump 3, Pump 4, Pump 5, Pump 6	Setting, System Password			

Submenu	Submenu	Submenu	Submenu	Submenu	Setting / Value	Comment				
Digital outputs	Local at controller	DO1	Settings	IO signal 1	OFF, True OR, Inverse OR, True AND, Inverse AND	Setting, System Password				
				IO number 1	1 [Unitless]	Setting, System Password				
				IO signal 2	OFF, True OR, Inverse OR, True AND, Inverse AND	Setting, System Password				
				IO number 2	1 [Unitless]	Setting, System Password				
				IO signal 3	OFF, True OR, Inverse OR, True AND, Inverse AND	Setting, System Password				
				IO number 3	1 [Unitless]	Setting, System Password				
				IO signal 4	OFF, True OR, Inverse OR, True AND, Inverse AND	Setting, System Password				
				IO number 4	1 [Unitless]	Setting, System Password				
				Data register	1 [Unitless]	Setting, System Password				
				Setpoint on	1 [Unitless]	Setting, System Password				
				Setpoint off	1 [Unitless]	Setting, System Password				
				Setpoint delay	1 s	Setting, System Password				
				Pre-alert time	1 s	Setting, System Password				
	Local at controller	DO1	Settings	Object		Pump 1, Pump 2, Pump 3, Pump 4, Pump 5, Pump 6, Pump pit	Setting, System Password			
				Time relay	Time relay	1, 2, 3, 4, 5, 6, 7, 8	Setting, System Password			
					Sequence	All, 1, 2, 3, 4	Setting, System Password			
					Signal source	Count down timer, IO on, IO off	Setting, System Password			
					One or none of lines below, depending on other settings.					
					Count down timer	1, 2, 3, 4, 5, 6, 7, 8, 9, 10, 11, 12	Setting, System Password			
					IO	1 [Unitless]	Setting, System Password			
					Pulse time	1 s	Setting, System Password			
				Normally open/closed		NO Normally open, NC Normally closed	Setting, System Password			
				Event trigger		OFF, ON	Setting, System Password			
				DO2 - DO4 = Menu selection, with preview, identical to above.						
				Module 1	DO1	Signal function			-Not connected-, -Reconnecting-, -Not connected-, -Connected-, -Error-, -Error-, -Not connected-, CAN ID error, CAN ID error	Status value
									OFF, Pump control, Reset motor protector, Pump fail, Not enough pumps avail., One pump fail, Mixer control, Drain pump control, Cleaner control, Com. timeout pulse, Remote control, Personnel alarm, High level, Alarm alert, Not ackn. alarm, Active alarm, Pump reversing, Logic IO, Data register setpoint, Auto reset alert, Valve control, Valve open, Valve close, Time relay, Pulse timer	Setting, System Password
	Status					-OFF-, -ON-	Status value			
	One or none of lines below, depending on port function.									

Submenu	Submenu	Submenu	Submenu	Submenu	Setting / Value	Comment	
Digital outputs	Module 1	DO1	Object		Pump 1, Pump 2, Pump 3, Pump 4, Pump 5, Pump 6, Mixer, Drain pump, All	Setting, System Password	
			Settings	Communication port		Modem port (RS232), RS485 port 1, RS485 port 2, USB port, GPRS data, Ethernet port (TCP/IP)	Setting, System Password
				Pulse time		1 s	Setting, System Password
				Communication timeout		1 s	Setting, System Password
				Object		B-Alarm, A-Alarm, All alarms	Setting, System Password
				Alert source		Unackn. alarms, Active alarms, Unackn. + active alarms	Setting, System Password
				On time		1 s	Setting, System Password
				Pause time		1 s	Setting, System Password
			Object		B-Alarm, A-Alarm, All alarms	Setting, System Password	
			Object		Pump 1, Pump 2, Pump 3, Pump 4, Pump 5, Pump 6	Setting, System Password	
			Settings	IO signal 1		OFF, True OR, Inverse OR, True AND, Inverse AND	Setting, System Password
				IO number 1		1 [Unitless]	Setting, System Password
				IO signal 2		OFF, True OR, Inverse OR, True AND, Inverse AND	Setting, System Password
				IO number 2		1 [Unitless]	Setting, System Password
				IO signal 3		OFF, True OR, Inverse OR, True AND, Inverse AND	Setting, System Password
				IO number 3		1 [Unitless]	Setting, System Password
				IO signal 4		OFF, True OR, Inverse OR, True AND, Inverse AND	Setting, System Password
				IO number 4		1 [Unitless]	Setting, System Password
				Data register		1 [Unitless]	Setting, System Password
				Setpoint on		1 [Unitless]	Setting, System Password
				Setpoint off		1 [Unitless]	Setting, System Password
				Setpoint delay		1 s	Setting, System Password
				Pre-alert time		1 s	Setting, System Password
			Object		Pump 1, Pump 2, Pump 3, Pump 4, Pump 5, Pump 6, Pump pit	Setting, System Password	
			Settings	Time relay		1, 2, 3, 4, 5, 6, 7, 8	Setting, System Password
				Sequence		All, 1, 2, 3, 4	Setting, System Password
				Signal source		Count down timer, IO on, IO off	Setting, System Password
				One or none of lines below, depending on other settings.			
				Count down timer		1, 2, 3, 4, 5, 6, 7, 8, 9, 10, 11, 12	Setting, System Password
				IO		1 [Unitless]	Setting, System Password
Pulse time		1 s		Setting, System Password			

Submenu	Submenu	Submenu	Submenu	Submenu	Setting / Value	Comment
Digital outputs	Module 1	DO1	Normally open/closed		NO Normally open, NC Normally closed	Setting, System Password
			Event trigger		OFF, ON	Setting, System Password
	DO2 - DO8 = Menu selection, with preview, identical to above.					
	Module 2 - 9 = Menu selection, with preview, identical to above.					
Leakage inputs	Module 1	DI1	Signal function		OFF, Leakage pump, Leakage mixer-drain pump	Setting, System Password
			Status		-OFF-, -ON-	Status value
	One or none of lines below, depending on port function.					
	Measure point		Generic, Oil chamber, Motor housing, Electr. con. box	Setting, System Password		
	One or none of lines below, depending on port function.					
	Object		Pump 1, Pump 2, Pump 3, Pump 4, Pump 5, Pump 6	Setting, System Password		
	Object		Mixer, Drain pump	Setting, No Password		
	DI2 - DI6 = Menu selection, with preview, identical to above.					
	Module 2 - 9 = Menu selection, with preview, identical to above.					

5.31 Settings: Communication

Table 5.31 shows the complete list of **Communication settings**.

Table 5.31

Submenu	Submenu	Submenu	Submenu	Setting / Value	Comment	
USB port	Protocol type			Modbus RTU, Modbus TCP	Setting, System Password	
	Message timeout			1 s	Setting, System Password	
	Cross reference			OFF, ON	Setting, System Password	
Modem port (RS232)	Baud rate			None, 300, 600, 1200, 2400, 4800, 9600, 19200, 38400, 57600, 115200, 230400	Setting, System Password	
	Parity			None, Odd, Even, Mark	Setting, System Password	
	Station ID			1 [Unitless]	Setting, System Password	
	Sim card PIN code			[Text String]	Setting, System Password	
	Modem type			OFF, CA 521, CA 523, CA 524, Generic SMS	Setting, System Password	
	Heart beat timeout			1 min	Setting, System Password	
	Alarm OFF heart beat			NO, YES	Setting, System Password	
	Application protocol			GPRS Hayes enable, Transparent	Setting, System Password	
	One or none of lines below, depending on other settings.					
	Settings Modbus	Protocol type			Modbus RTU, Modbus TCP	Setting, System Password
Protocol ID				1 [Unitless]	Setting, System Password	
Message timeout				1 s	Setting, System Password	

Submenu	Submenu	Submenu	Submenu	Setting / Value	Comment	
Modem port (RS232)	Settings Modbus	Cross reference		OFF, ON	Setting, System Password	
	Settings GPRS	TCP type		Aquaweb client, TCP server (fixed IP), TCP server + heart beat	Setting, System Password	
		Server IP address		[Text String]	Setting, System Password	
		Server TCP port number		1 [Unitless]	Setting, System Password	
		GPRS APN part 1		[Text String]	Setting, System Password	
		GPRS APN part 2		[Text String]	Setting, System Password	
		GPRS User name		[Text String]	Setting, System Password	
		GPRS Password		[Text String]	Setting, System Password	
		Protocol type		Modbus RTU, Modbus TCP	Setting, System Password	
		Protocol ID		1 [Unitless]	Setting, System Password	
		Message timeout		1 s	Setting, System Password	
		Cross reference		OFF, ON	Setting, System Password	
		Settings Modbus	Protocol type		Modbus RTU, Modbus TCP	Setting, System Password
	Protocol ID			1 [Unitless]	Setting, System Password	
	Message timeout			1 s	Setting, System Password	
	Cross reference			OFF, ON	Setting, System Password	
	One or none of lines below, depending on other settings.					
	Settings SMS	SMS alarm enable		Disabled, A-ON, A-ON/OFF, A+B-ON, A+B-ON/OFF	Setting, System Password	
		Second SMS number		Backup only, Send always	Setting, System Password	
		First SMS number		[Text String]	Setting, System Password	
Second SMS number			[Text String]	Setting, System Password		
RS485 port 1	Baud rate		None, 300, 600, 1200, 2400, 4800, 9600, 19200, 38400, 57600, 115200, 230400, 460800	Setting, System Password		
	Parity		None, Odd, Even, Mark	Setting, System Password		
	Application protocol		Modbus slave, Modbus master	Setting, System Password		
	Protocol type		Modbus RTU, Modbus TCP	Setting, System Password		
	One or none of lines below, depending on other settings.					
	Protocol ID			1 [Unitless]	Setting, System Password	
	Poll interval			1 s	Setting, System Password	
	One or none of lines below, depending on other settings.					
	Cross reference			OFF, ON	Setting, System Password	
	Message timeout			1 s	Setting, System Password	

Submenu	Submenu	Submenu	Submenu	Setting / Value	Comment	
RS485 port 2	Baud rate			None, 300, 600, 1200, 2400, 4800, 9600, 19200, 38400, 57600, 115200, 230400, 460800	Setting, System Password	
	Parity			None, Odd, Even, Mark	Setting, System Password	
	Application protocol			Modbus slave, Modbus master	Setting, System Password	
	Protocol type			Modbus RTU, Modbus TCP	Setting, System Password	
	One or none of lines below, depending on other settings.					
	Protocol ID			1 [Unitless]	Setting, System Password	
	Poll interval			1 s	Setting, System Password	
	One or none of lines below, depending on other settings.					
	Cross reference			OFF, ON	Setting, System Password	
	Message timeout			1 s	Setting, System Password	
	Ethernet port (TCP/IP)	Hardware			OFF, ON	Setting, System Password
Protocol type				Modbus RTU, Modbus TCP	Setting, System Password	
Ethernet port (TCP/IP)	Protocol ID			1 [Unitless]	Setting, System Password	
	Message timeout			1 s	Setting, System Password	
	Cross reference			OFF, ON	Setting, System Password	
	Port number			1 [Unitless]	Setting, System Password	
	Static/Dynamic IP			Static IP, Dynamic IP (DHCP)	Setting, System Password	
	One or none of lines below, depending on other settings.					
	Set static IP		IP address		[Text String]	Setting, System Password
			Net Mask		[Text String]	Setting, System Password
			Gateway		[Text String]	Setting, System Password
	Show dynamic IP		IP address		[Text String]	Status value
			Net Mask		[Text String]	Status value
			Gateway		[Text String]	Status value
			Port number		1 [Unitless]	Status value
	IO Modules (CAN bus)	IO Module lost alarms	CA 811	ID:1		
ID:2					Menu selection, Identical to above.	
ID:3					Menu selection, Identical to above.	
ID:4					Menu selection, Identical to above.	
ID:5					Menu selection, Identical to above.	
ID:6					Menu selection, Identical to above.	
ID:7					Menu selection, Identical to above.	
ID:8					Menu selection, Identical to above.	
ID:9					Menu selection, Identical to above.	
CA 821, CA 831, CA 832. CA 841, CA 861 = Menu selection, Identical to above.						

5.32 Settings: Field bus modules (RS485)

Table 5.32 shows the complete list of **Field bus modules (RS485) settings**.

Table 5.32

Submenu	Submenu	Submenu	Setting / Value	Comment	
Main pwr. mon.	Slave ID		1 [Unitless]	Setting, System Password	
	Bus selection		RS485 port 1, RS485 port 2	Setting, System Password	
	Manufacturer		None, Accuenergy, Schneider, Lumel, Carlo Gavazzi	Setting, System Password	
	One or none of lines below, depending on manufacturer settings				
	Model			None, Acuvim II	Setting, System Password
				None, PM 710, PM 5110	Setting, System Password
				None, ND 10	Setting, System Password
				None, EM210	Setting, System Password
Main pwr. mon.	Alarm settings	Phase missing			
		Pwr. mon. Com. error			
		Over voltage			
		Under voltage			
		Unbalanced voltage			
		High frequency			
		Low frequency			
	Use P1 PM for main pwr data		NO, YES	Setting, System Password	
Pwr.mon.P1	Slave ID		1 [Unitless]	Setting, System Password	
	Bus selection		RS485 port 1, RS485 port 2	Setting, System Password	
	Manufacturer		None, Accuenergy, Schneider, Lumel, Carlo Gavazzi	Setting, System Password	
	One or none of lines below, depending on manufacturer settings				
	Model		None, Acuvim II	Setting, System Password	
	Model		None, PM 710, PM 5110	Setting, System Password	
	Model		None, ND 10	Setting, System Password	
	Model		None, EM210	Setting, System Password	
	Alarm com. error				
Pwr.mon.P2 - Pwr.mon.P6 = Menu selection, with preview, identical to above.					
M.Drive P1	Slave ID		1 [Unitless]	Setting, System Password	
	Bus selection		RS485 port 1, RS485 port 2	Setting, System Password	
	Manufacturer		None, Invertek, Schneider, Danfoss, ABB, Emotron, NFO drives, Vacon, YASKAWA	Setting, System Password	
	One or none of lines below, depending on manufacturer settings				

Submenu	Submenu	Submenu	Setting / Value	Comment
M.Drive P1	Model		None, Optidrive	Setting, System Password
			None, ATV 61, ATS 48, ATV 600 series, ATV 12, ATS 22, ATV 320	Setting, System Password
			None, FC 200, MCD 200, MCD 500	Setting, System Password
			None, ACQ 810, ACS 580, ACS 550, PSTX, ACQ580, ACS880	Setting, System Password
			None, TSA Softstarter, FDU 2	Setting, System Password
			None, Sinus	Setting, System Password
			None, Vacon 100, Vacon 20	Setting, System Password
			None, P1000 <= 11KW, P1000 > 11KW	Setting, System Password
	Modbus control		Monitor, & Control on/off, & Manual speed, & Auto speed	Setting, System Password
	Max. set frequency VFD		0.1 Hz	Setting, System Password
	Min. set frequency VFD		0.1 Hz	Setting, System Password
	Pump cap at min. freq.		0.1 %	Setting, System Password
	Set manual frequency		0.1 Hz	Setting, System Password
	Set reverse frequency		0.1 Hz	Setting, System Password
	Control frequency		0.01 Hz	Setting, System Password
	A-0 sw. blocks Modbus com.		NO, YES	Setting, System Password
	Drive fault alarm	Motor drive alarm		
		Enable auto reset	NO, YES	Setting, System Password
		Ackn. alarm reset drive	NO, YES	Setting, System Password
	Alarm com. error			
M.Drive P2 - M.Drive P6 = Menu selection, with preview, identical to above.				

5.33 Select language

Table 5.33 shows the complete list of **language settings**.

Table 5.33

Submenu	Setting / Value	Comment
System language	English, French, German, Spanish, Danish, Dutch, Italian, Norwegian, Polish, Portuguese (Brazil), Swedish, Turkish	Setting, No Password

5.34 Calibrate touch screen

Table 5.34 shows the complete list of **calibration settings**.

Table 5.34

Submenu	Setting / Value	Comment
Calibrate touch screen	NO, YES	Setting, No Password

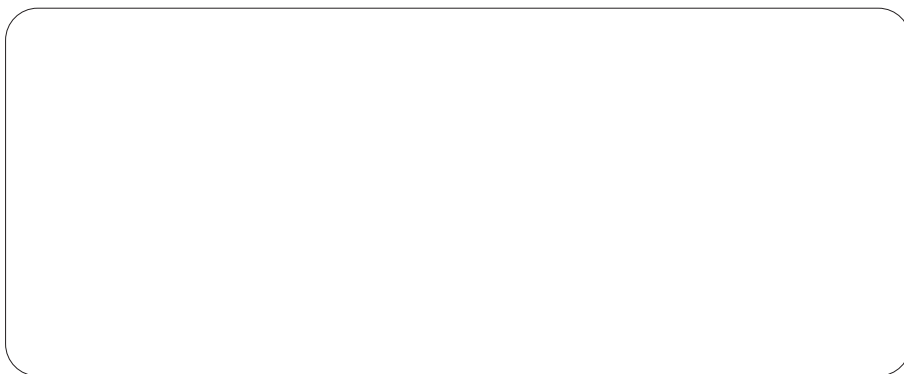

SULZER

Sulzer Pump Solutions Ireland Ltd., Clonard Road, Wexford, Ireland
Tel. +353 53 91 63 200, www.sulzer.com