

# Submersible drainage pump J 7

**SULZER**

## Specification

J 7 medium head, single-phase electric submersible pump with built-in float switch.

Maximum submergence: 7 m.

Max temperature of pumped medium at max power input and continuous duty 40 °C.

Protection class IP68.

pH of the pumped medium 6.5-8.5.

Strainer hole: 6 mm.

## Electric motor

Single-phase induction motor with built-in capacitor, 50 Hz.

Class F insulation.

Motor rating  $P_2$ : 0.75 kW. Speed: 2850 rpm

Voltage, V	230
Nominal current, A	5

## Power cable

10 m type H07RN8-F: 3 x 1.0 sq.mm.

## Motor protection

Built-in thermal protector.

## Shaft seal

Double mechanical seal in oil bath: Ceramic-Sic/Carbon-Ceramic.

## Bearings

Sealed ball bearing.

## Discharge connections

2" hose connections.

2" B.S.P. threaded connections.

## Weight

17.3 kg

## Options and accessories

2" Storz C connection

Reinforced hose.

## Materials

Description	Material
Castings	Cast iron
Casing	Stainless steel
Shaft	Stainless steel 1.4021
Impeller	Ductile iron
Wear parts	Nitrile rubber
O-rings	Nitrile rubber



## Performance curve

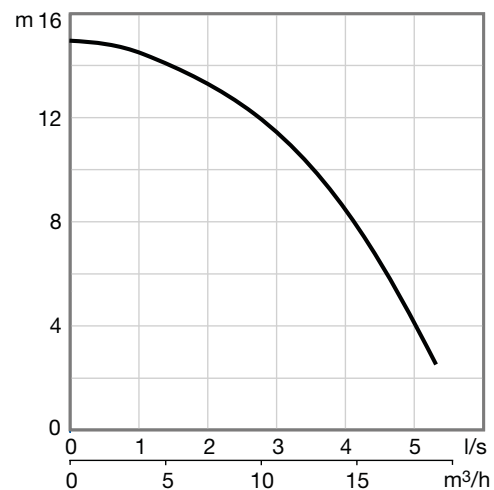

## Dimensions (mm)

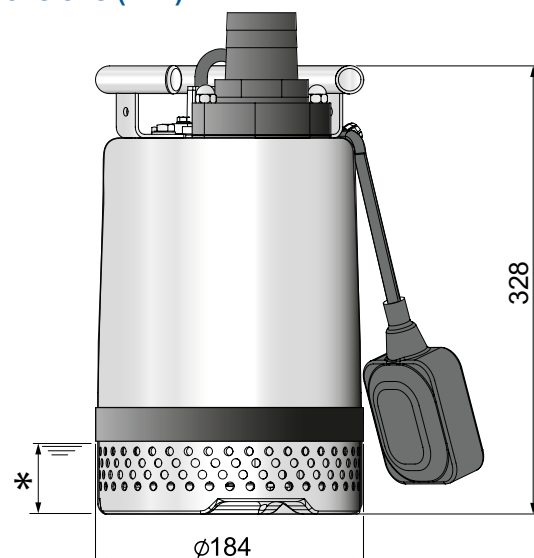

\* Continuous running water level 76 mm

[www.sulzer.com](http://www.sulzer.com)

J 7 50Hz en (09.2022), Copyright © Sulzer Ltd 2022

This document does not provide a warranty or guarantee of any kind. Please contact us for a description of the warranties and guarantees offered with our products. Directions for use and safety will be given separately. All information herein is subject to change without notice.