

Submersible drainage pump XJ 900

SULZER

Specification

Electric submersible pump with double outer casing.
 Maximum submergence: 262 ft. Protection class IP68.
 Max temperature of pumped medium at max power input and continuous duty 104 °F.
 Max medium density 0.0397 lbs/inch³. pH of the pumped medium 5-8.
 Strainer hole: 5/16" x 1 5/16". Max number of starts 15/hr.

XJ 900 ND High flow, 3-phase
XJ 900 HD High head, 3-phase

IE3 electric motor

3-phase squirrel-cage induction motor, 60 Hz.
 Service factor 1.1. Class F insulation.
 Motor rating P₂: 145 Hp (108 kW). 2 pol. Speed: 3560 rpm.
 η: 96.4 (50 %), 96.4 (75 %), 96.0 (100 % load).

Voltage, V	380*	480	575
Nominal current, A	190	154	124

* 380 V not available in CSA

Motor protection

- Thermal control system with temperature sensors in the motor windings for automatic shut-down in case of overheating
- Seal monitoring system with leakage sensor in the junction box and motor chamber for automatic shut-down if water has entered into the pump
- Leakage sensor in the oil chamber that signals an inspection alert, indicating the presence of water in the oil
- Optional bearing monitoring system with temperature sensors at upper and lower bearing indicating excessive temperature

Power cable

100 ft type W type: allowed lengths 65-325 ft
 Type AWG 2/0 (480 V, 575 V)
 Control cable: SOOW 12AWG16, 16AWG16

Shaft seal

Double mechanical seal in oil bath.
 Primary seal: Silicon carbide on silicon carbide.
 Secondary seal: Silicon carbide on silicon carbide.

Bearings

Upper bearing: Single-row cylindrical roller bearing.
 Lower bearing: Double-row angular contact ball bearing.

Discharge connections

- 4" discharge:
 Flanged connection Class 250 ASME B16.1 1998 (Standard HD)
- 6" discharge:
 Flanged connection Class 150 ASM B16.5 1998 (Standard ND)

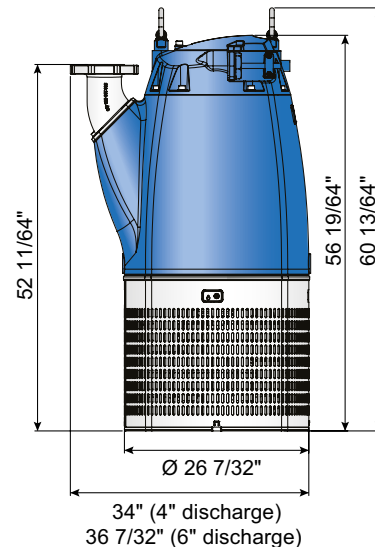
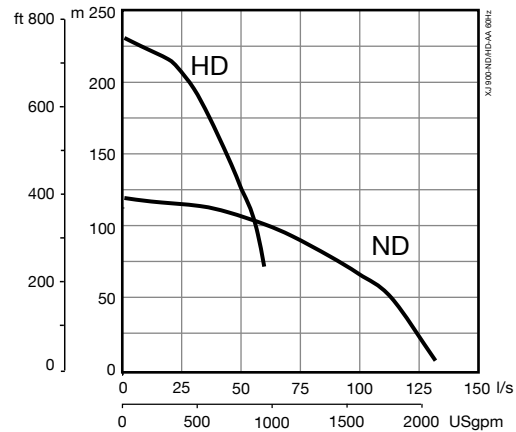

Weight

2600 lb. (without cable)

Options and accessories

HD/ND conversion kit
 Bearing temperature sensors
 Repair kit
 Hydraulic service kit

CSA approved – LR 51412 
 ISO9001 certified

Materials

Description	Material	EN	ASTM
Structural castings	Cast iron	EN-GJL-250	ASTM A48 - Class 35
Volute casings	Cast iron	EN-GJL-250	ASTM A48 - Class 35
Outer jacket / Discharge	Ductile iron	EN-GJS-400-18	ASTM A536 60-40-18
Strainer / Handle	Stainless steel	10088:X5CrNi18-10 (1.4301)	AISI 304
Rotor shaft	Stainless steel	10088:X20Cr13 (1.4021)	AISI 420
Impeller / Wear rings / Flow elbows	White cast iron	EN-GJN-HV600(XCr23)	ASTM A 532: Alloy III A
Fasteners	Stainless steel	10088:X5CrNiMo 17122 (1.4401)	AISI 316
Volute coating / O-rings	Nitrile rubber		
Coating	2 component epoxy paint 120 µm		