

SULZER



Installation, operation and maintenance instructions
Light Wastewater Pump Type ABS MF 154 - 804 /
Submersible Grinder Pump Type ABS Piranha 08 - 09















Table of contents

1. Important notice	3
2. Symbols and notices	3
3. General	4
3.1. Hydraulics	4
3.2. Intended use and application	4
4. Safety	5
5. Technical data	5
5.1. Nameplate	5
5.1.1. Nameplate drawings	6
6. Lifting and transport	6
6.1. Lifting	6
6.2. Transport	7
7. Set-up and installation	7
7.1. Discharge line	8
7.2. Installation	8
8. Electrical connection	9
8.1. Wiring diagrams	10
9. Commissioning	11
9.1. Direction of rotation	11
9.1.1. Checking direction of rotation	11
9.1.2. Changing direction of rotation	12
10. Maintenance and service	13
10.1. General maintenance instructions	13
10.2. Lifting station maintenance intervals (EN 12056)	13
10.3. Piranha shredding system	14
10.4. Oil quantities	14
10.5. Cleaning	15
11. Company details	15

1. Important notice

	NOTE
	The original version of this document is in English. All other languages are a translation of the original. In case of a discrepancy, the English version will prevail.
	NOTE
	The layout and wording of the online version of this manual may vary from the printed version. The same information is provided in both.

2. Symbols and notices

	 DANGER
	Presence of dangerous voltage
	 DANGER
	Danger of an explosion occurring.
	 WARNING
	Hot surface - danger of burn or injury.
	 WARNING
	Hot liquid - danger of burn or injury.
	 CAUTION
	Non-compliance may result in personal injury.
	ATTENTION
	Non-observance may result in damage to the unit or negatively affect its performance.
	NOTE
	Important information for particular attention.

3. General

	NOTE
	Sulzer reserves the right to alter specifications due to technical developments.

3.1. Hydraulics

Table 1.

Light Wastewater Pump Type ABS MF			Submersible Grinder Pump Type ABS Piranha	
154	354	565	08	09
154HW	404	665		
324	504	804		
334				

3.2. Intended use and application



The MF / Piranha series are reliable quality products designed for the following applications:

- Pumping of clear water.
- **MF 154 - 804:** Blockage-free pumping of faecal-free liquids, with a light concentration of solids (maximum 60 mm depending on the model).
- **MF-VO:** Includes a protective screen for locations such as building sites. For liquids with solids up to 7 mm.
- **MF 154HW:** The pumping of high temperature liquids to a maximum of 80 °C. All discharge pipework from the pump must be temperature resistant. This is the responsibility of the customer. The HW version of the MF pump is designed for short term (S2) and intermittent (S3) operation only, operating in 8 minute / 10% cycles. E.g. 0.8 minutes ON / 7.2 minutes OFF.
- **Piranha 08 & 09:** includes a shredding system. For sewage containing faecal matter, and liquids with a light concentration of non-abrasive solids.

These units must not be used in certain applications e.g. operating within flammable, combustible, chemical, corrosive, or explosive liquids.

	ATTENTION
	The maximum allowable temperature of the medium is: MF 154 - 804 and Piranha 08 & 09 = 40 °C / 104 °F. MF 154HW = 80 °C.



	ATTENTION
	Check that the pump materials are resistant to the medium being pumped.

	ATTENTION
	If damage occurs due to failure caused by operating errors, the absence of mains voltage or a technical defect, resulting in the medium escaping, extra measures are required to avoid increased damage. Consider the conditions, an emergency generator, an additional appropriately connected second unit or the use of an off-grid alarm system.
	ATTENTION
	Always consult with your local Sulzer representative for advice on approved use and application before installing the pump.
	ATTENTION
	Please observe the country-specific EX regulations regarding the pumping of wastewater containing faecal matter.

4. Safety

The general and specific health and safety guidelines are described in detail in the “Safety Instructions for Sulzer Products Type ABS” booklet. If anything is unclear, or you have any questions regarding safety make certain to contact the manufacturer Sulzer.

This unit can be used by children aged 8 years and above, and persons with reduced physical, sensory, or mental capabilities, or lack of experience and knowledge, when they have been given supervision or instruction concerning the safe use of the device and understand the hazards involved. Children must not play with the appliance. Cleaning and user maintenance should not be performed by children without supervision.

	 CAUTION
	Under no circumstances place a hand inside the suction or discharge openings unless the pump is completely isolated from the power supply.

5. Technical data

Maximum noise level ≤ 70 dB. In some types of installations it is possible that during operation the noise level of 70 dB(A) or the measured noise level may be exceeded.

Detailed technical information is available in the technical data sheet which can be downloaded from <https://www.sulzer.com>

5.1. Nameplate

We recommend that you record the data from the standard nameplate on the unit in the legend below, and maintain it as a source of reference for the ordering of spare parts, repeat orders and general queries.

Always state the type, item number and serial number in all communications.

5.1.1. Nameplate drawings

Figure 1. Standard nameplate

SULZER		CE	xx/xxxx	IP 68
Typ				
Nr		SN		
U	V	Ph	A	Hz
P1	kW			
Qmax	m ³ /h	Hmax	1/min	
		∇		m
Sulzer Pump Solutions Ireland Ltd. Wexford, Ireland www.sulzer.com				
Made in Ireland				

Table 2. Legend

Legend	Description	Data
Typ	Pump type	
Nr.	Item number	
SN	Serial number	
xx/xxxx	Production date (week/ year)	
U	Rated voltage	V
	Rated current	A
	Frequency	Hz
P1	Rated input power	kW
1/min	Speed	min-1
Qmax	Max. flow	m ³ /h
Hmax	Max. head	m
∇	Max. submergence depth	m

6. Lifting and transport

6.1. Lifting

	ATTENTION
Observe the total weight of the Sulzer units and their attached components! (see nameplate for weight of base unit).	

The duplicate nameplate provided must always be located and visible close to where the unit is installed (e.g. at the terminal boxes / control panel where the cables are connected).

	NOTE
	Lifting equipment must be used if the total unit weight and attached accessories exceeds local manual lifting safety regulations.



The total weight of the unit and accessories must be observed when specifying the safe working load of any lifting equipment! The lifting equipment, e.g. crane and chains, must have adequate lifting capacity. The hoist must be adequately dimensioned for the total weight of the Sulzer units (including lifting chains or steel ropes, and all accessories which may be attached). The end user assumes sole responsibility that lifting equipment is certified, in good condition, and inspected regularly by a competent person at intervals in accordance with local regulations. Worn or damaged lifting equipment must not be used and must be properly disposed of. Lifting equipment must also comply with the local safety rules and regulations

	NOTE
	The guidelines for the safe use of chains, ropes and shackles supplied by Sulzer are outlined in the Lifting Equipment manual provided with the items and must be fully adhered to.

6.2. Transport



During transport, care should be taken that the pump is not dropped or thrown. The unit is fitted with a lifting device to which a chain and shackle may be attached for transport purposes.

	 DANGER
	Dangerous voltage The pump must be raised by the lifting hoop and never by the power cable.

	 CAUTION
	Hoists must be adequately dimensioned for the weight of the unit.

	ATTENTION
	All relevant safety regulations and good general technical practice must be complied with.

7. Set-up and installation

	 DANGER
	The regulations covering the use of pumps in sewage applications, together with all regulations involving the use of explosion-proof motors, should be observed. The cable ducting to the control panel should be sealed off in a gas-tight manner by the use of a foaming material after the cable and control circuits have been pulled through. In particular the safety regulations covering work in enclosed areas in sewage plants should be observed together with general good technical practice.

7.1. Discharge line

The discharge line must be installed in compliance with the relevant regulations. DIN 1986/100 and EN 12056 applies in particular to the following:

- The discharge line should be fitted with a backwash loop (180° bend) located above the backwash level and should then flow by gravity into the collection line or sewer.
- The discharge line should not be connected to a down pipe.
- No other inflows or discharge lines should be connected to this discharge line.



ATTENTION

The discharge line should be installed so that it is not affected by frost.

7.2. Installation

Figure 2. Submerged in a concrete sump

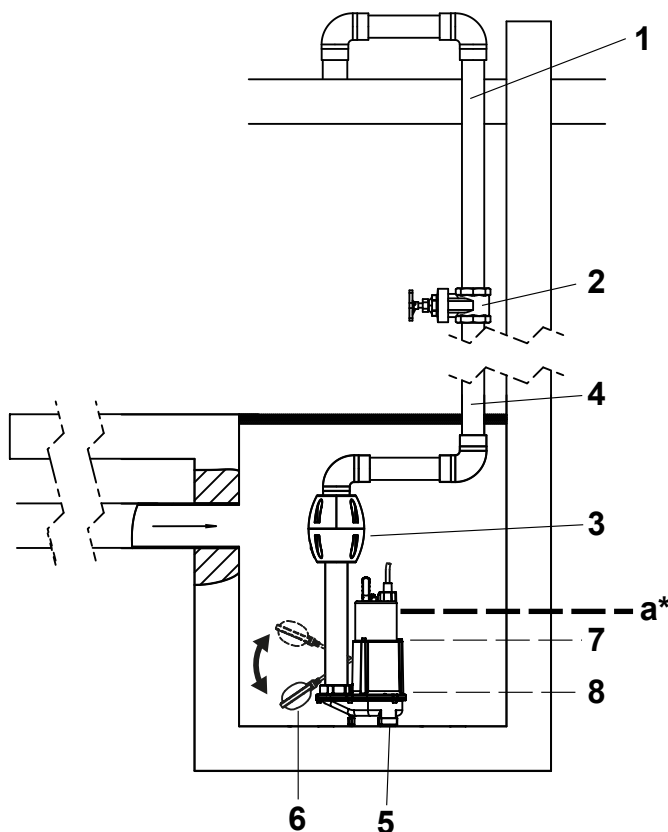

Legend:

- 1 Backwash loop
- 2 Shut-off valve
- 3 Non-return valve
- 4 Discharge line
- 5 Submersible pump
- 6 KS Float: up = on, down = off
- 7 Switch-on level
- 8 Switch-off level

	ATTENTION
	<p>Please observe the following important installation instructions as a function of the medium temperature when installing a hot water pump type MF 154HW:</p> <ol style="list-style-type: none"> 1. The pump can be fully immersed in the medium up to max. 60 °C temperature. 2. Above 60 °C to max. 80 °C medium temperature, the maximum water level (see “a” on figure above) must not be exceeded. <p>The power cable of the pump must be fixed in such a way that it cannot come into contact with the medium when above 60 °C. Failure to follow these instructions may result in damage to the pump and/or loss of warranty.</p>

	NOTE
	<p>Regulations for connecting to the sewer lines vary from country to country. Consult your local regulatory body.</p>

8. Electrical connection

	DANGER
	<p>Dangerous voltage</p> <p>Before commissioning, an expert should check that one of the necessary electrical protective devices is available. Earthing, neutral, earth leakage circuit breakers, etc. must comply with the regulations of the local electricity supply authority and a qualified person should check that these are in perfect order.</p>

	ATTENTION
	<p>The power supply system on site must comply with local regulations with regard to cross-sectional area and maximum voltage drop. The voltage stated on the nameplate of the pump must correspond to that of the mains.</p>

Suitably rated means of disconnection shall be incorporated in the fixed wiring by the installer for all pumps in accordance with applicable local National codes.

The power supply cable must be protected by an adequately dimensioned slow-blow fuse corresponding to the rated power of the pump.



	DANGER
	<p>Dangerous voltage</p> <p>The incoming power supply as well as the connection of the pump itself to the terminals on the control panel must comply with the circuit diagram of the control panel as well as the motor connection diagrams and must be carried out by a qualified person.</p>

All relevant safety regulations as well as general good technical practice must be complied with.

Submersible pumps used outdoors must be fitted with a power cable of at least 10 meter length. Other regulations may apply in different countries.

In all installations, the power supply to the pump must be via a residual current device (e.g. RCD, ELCB, RCBO etc.) with a rated residual operating current in accordance with local regulations. For installations not having a fixed residual current device the pump must be plugged into the power supply through a portable version of the device.

All three phase pumps must be installed with motor starting and overload protective devices in the fixed wiring by the installer. Such motor control and protective devices must comply with the requirements of IEC standard 60947-4-1. They must be rated for the motor that they control, and wired and set/adjusted according to the instructions provided by the manufacturer. In addition, the overload protective device that is responsive to the motor current shall be set / adjusted to 125% of the marked rated current.

	 DANGER
	<p>Dangerous voltage Risk of electrical shock. Do not remove cord and strain relief and do not connect conduit to pump.</p>
	NOTE
	Please consult your electrician.

8.1. Wiring diagrams

Table 3.

Three phase	Single phase
50 Hz:	50 Hz:
MF 334D	MF 154W / HW
MF 404D	MF 324W
MF 665D	MF 354W
MF 804D	MF 504W
Piranha 08/09D	MF 565W
	Piranha 08/09W

Figure 3. (a): Three phase wiring. (b): Single phase wiring.

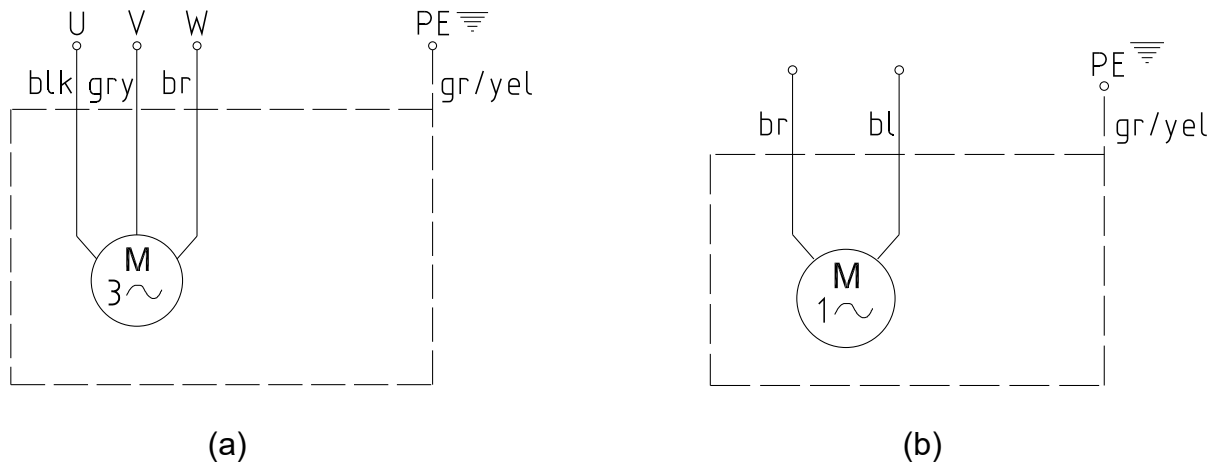

U, V, W = live	blk = black	br = brown
PE = earth	bl = blue	gry = grey
gr/yel = green/ yellow		

9. Commissioning

	CAUTION
	All safety hints in other sections must be observed!

Before commissioning, the pump should be checked and a functional test carried out. Particular attention should be paid to the following:

- Have the electrical connections been carried out in accordance with regulations?
- Is the motor overload switch correctly set?
- Does the unit sit correctly on the pedestal?
- Is the direction of rotation correct - even if run via an emergency generator?
- Are the switching ON and switching OFF levels set correctly?
- Are the level control switches functioning correctly?
- Are the required gate valves (where fitted) open?
- Do the non-return valves (where fitted) function easily?
- Was the sump cleaned out?
- Have the inflow and outflows of the pump station been cleaned and checked?

9.1. Direction of rotation

9.1.1. Checking direction of rotation

When three phase units are being commissioned for the first time, and also when used on a new site, the direction of rotation must be carefully checked by a qualified person.

	CAUTION
	<p>The direction of rotation should only be altered by a qualified person.</p> <p>When checking the direction of rotation, the pump should be secured in such a manner that no danger to personnel is caused by the rotating impeller or by the resulting air flow. Do not place your hand into the hydraulic system!</p>

	CAUTION
	<p>When checking the direction of rotation, or when starting the unit, pay attention to the START REACTION. This can be very powerful and cause the pump to jerk in the opposite direction to the direction of rotation.</p>

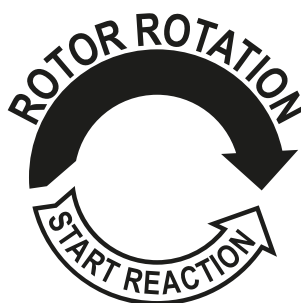

	ATTENTION
	<p>When viewed from above, the direction of rotation is correct if the impeller rotates in a clockwise manner.</p>

	NOTE
	<p>The start reaction is anti-clockwise.</p>

	ATTENTION
	<p>If a number of pumps are connected to a single control panel then each unit must be individually checked.</p>







	ATTENTION
	<p>The mains supply to the control panel should have a clockwise rotation. If the leads are connected in accordance with the circuit diagram and lead designations, the direction of rotation will be correct.</p>

9.1.2. Changing direction of rotation

	CAUTION
	<p>The direction of rotation should only be altered by a qualified person.</p> <p>If the direction of rotation is incorrect then this is altered by changing over two phases of the power supply cable in the control panel. The direction of rotation should then be rechecked.</p>

	NOTE
	<p>The direction of rotation measuring device monitors the direction of rotation of the mains supply or that of an emergency generator.</p>

10. Maintenance and service

	 DANGER
	<p>Before commencing any maintenance work the pump should be completely disconnected from the mains by a qualified person and care should be taken that it cannot be inadvertently switched back on.</p>
	 CAUTION
	<p>When carrying out on-site service or maintenance work i.e. cleaning, venting, fluid inspection or changing, and adjustment of the bottom plate gap, the safety regulations covering work in enclosed areas of sewage installations as well as good general technical practices should be followed.</p>
NOTE	
<p>Repair work must only be carried out by qualified personnel approved by Sulzer.</p>	
	 DANGER
	<p>To avoid danger if the power cable is damaged, it must be replaced by the manufacturer or its service agent or a similarly qualified person.</p>
	ATTENTION
	<p>The maintenance hints given here are not designed for “do-it-yourself” repairs as special technical knowledge is required</p>

10.1. General maintenance instructions

Sulzer units are reliable quality products, each being subjected to careful final inspection. Lubricated-for-life ball bearings, together with monitoring devices, ensure optimum reliability provided that the unit has been connected and operated in accordance with the operating instructions.

Should, nevertheless, a malfunction occur, do not improvise but ask your Sulzer customer service department for assistance.

This applies particularly if the pump is continually switched off by the current overload in the control panel or by the alarm.

Regular inspection and care is recommended to ensure a long service life. Service intervals vary for Sulzer units depending on installation and application. Contact your local Sulzer Service Center for more information. A maintenance contract with our Service Department will guarantee the best technical service.

The Sulzer service organisation would be pleased to advise you on any applications you may have and to assist you in solving any problems you may encounter.

When carrying out repairs, only original spare parts supplied by the manufacturer should be used. Sulzer warranty conditions are only valid provided repair work has been carried out in a Sulzer approved workshop, and original Sulzer spare parts have been used.

10.2. Lifting station maintenance intervals (EN 12056)

It is recommended that the lifting station is inspected monthly and its function checked. In the case of any irregularities, deformations, or color changes, report immediately.

In accordance with EN regulations, the lifting station should be maintained by a qualified person at the following intervals:

- Commercial premises = every three months.
- Apartment blocks = every six months.
- A single family home = once a year.

A maintenance contract with a qualified company is recommended.

10.3. Piranha shredding system

The shredding system is a wearing part, and as such may need to be replaced. A reduction in cutting performance can reduce the output. We recommend that the shredding system is inspected regularly. This is particularly so if sewage containing sand is being pumped. Regular inspection and care is recommended to ensure a long service life.

The Sulzer Service Organisation would be pleased to advise you on any applications you may have and to assist you in solving your pumping problems.

	ATTENTION
	Before starting the pump ensure that the shredding rotor can rotate freely.

10.4. Oil quantities

	NOTE
	The seal chamber between the motor and the hydraulic section has been filled at manufacture with lubricating oil.

Table 4. Motor

Pump type	Liters		Pump type	Liters
MF 334D	N/A		MF 154W / HW	N/A
MF 404D	0.5		MF 324W	N/A
MF 665D	0.5		MF 354W	0.5
MF 804D	0.5		MF 504W	0.5
Piranha 08/09D	0.5		MF 565W	0.5
			Piranha 08/09W	0.5

Table 5. Seal chamber

Pump type	Liters		Pump type	Liters
MF 334D	0.02		MF 154W / HW	0.02
MF 404D	0.02		MF 324W	0.02
MF 665D	0.02		MF 354W	0.02
MF 804D	0.02		MF 504W	0.02
Piranha 08/09D	0.02		MF 565W	0.02
			Piranha 08/09W	0.02

Specification: White mineral VG8 - VG10

	NOTE
	An oil change is only necessary if a fault occurs.

10.5. Cleaning

If the pump is used for transportable applications, then in order to avoid deposits of dirt and encrustation it should be cleaned after each usage by pumping clear water. In the case of fixed installation, we recommend that the functioning of the automatic level control system be checked regularly. By switching the selection switch (switch setting "HAND") the sump will be emptied. If deposits of dirt are visible on the floats then these should be cleaned. After cleaning, the pump should be rinsed out with clear water and a number of automatic pumping cycles carried out.

11. Company details

Address: Sulzer Pump Solutions Ireland Ltd., Clonard Road, Wexford, Ireland

Telephone: +353 53 91 63 200

Website: www.sulzer.com