

HST™ 2500 Turbocompressor



A highly efficient and reliable single-stage centrifugal compressor for the provision of oil-free, low-pressure air.

Construction

High-speed electric motor

A vertically mounted high-frequency electric motor for variable speed operation. The motor is air-cooled by an integrated shaft mounted fan and the windings are protected by Pt100-sensors monitored by the local control system.

Air end

The impeller has been designed to optimize performance and is machined from a solid piece of high-strength aluminum alloy. The volute and other main components are made from cast aluminum. A non-contact seal between air-end and motor minimizes losses to maintain high efficiency.

Variable frequency drive

Flow control is provided by a built-in variable frequency drive which also accommodates variations in outlet pressure and ambient inlet conditions. The variable frequency drive's soft-start facility eliminates peak starting currents.

Active magnetic bearings

Two radial bearings and two axial bearings support the rotor. The magnetic bearing controller uses data provided by multiple sensors to continuously manage the position of the rotor.

Blow-off valve

The blow-off valve is mounted on the compressor assembly with attenuation provided by an external silencer.

Acoustic enclosure

The enclosure provides protection for the electrical and mechanical components and provides efficient noise attenuation for the machine. The enclosure is constructed from zinc-plated steel. It is suitable for indoor use (IP33D / NEMA 2).



Compressor Control

Local control

The built-in local Human-Machine-Interface (HMI) provides control and monitoring for the safe and efficient operation of the machine. Flow may be controlled directly by the operator, or alternatively, the turbocompressor can follow a given reference value. The local HMI uses a keypad and text display to provide access to the operator.

Connections

Analog and digital control and monitoring connections are built in. Fieldbus connections such as Profibus, Profinet, Modbus RTU, Modbus TCP, and EtherNet/IP are available as options.

Remote connections

A secure connection facilitating service and monitoring can be ordered as an option.

Options

Various options for handling special requirements regarding e.g., temperature, dusty environments and locations with high moisture can be selected.

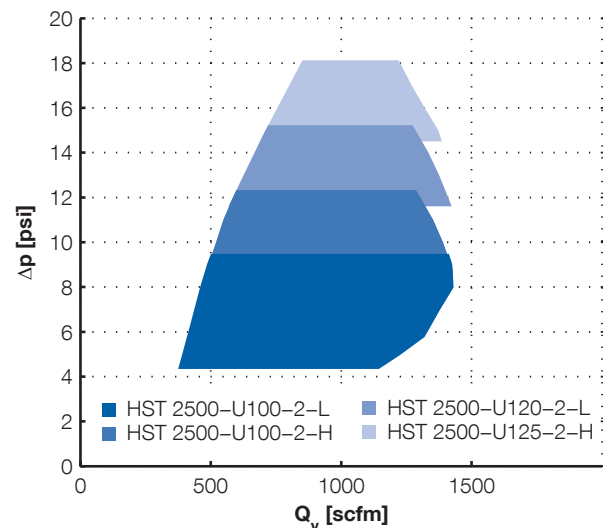
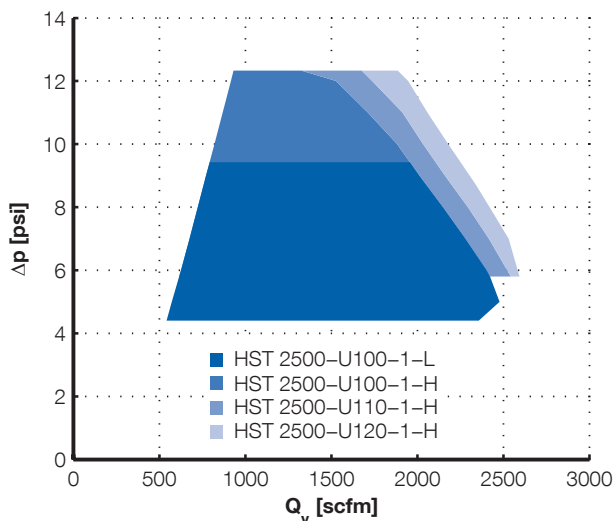

Accessories

Required accessories for installation such as flexible joints, valves, silencers, and air filters are available from Sulzer.

Performance Testing

Compressor performance tests are performed on every machine manufactured and certificates issued to confirm compliance. The tests are carried out at the Sulzer factory test facility. Performance is guaranteed with a manufacturing tolerance of $\pm 2\%$ and a measurement tolerance according to ISO 5389. Optionally tests can be performed according to ISO 5389 or ASME PTC 10. The test can be witnessed by the customer or a third party inspector.

Certification and Standards

The compressor is certified according to the relevant UL and CSA standards:

- UL 1450
- CSA C22.2 No. 68

The product is designed and manufactured in accordance with EN 61800-3 standard and intended for use in second environment locations, e.g., in industrial areas.

Installation Conditions ⁽¹⁾

Altitude	
Maximum altitude	8200 ft above sea level ⁽²⁾
Air quality	
Permitted chemical vapors	IEC 60721-3-3 class 3C3
Ambient conditions	
Ambient temperature range	Min. 14 °F, max. +113 °F
Ambient relative humidity	< 95 %, non-condensing, non-corrosive, no dripping water
Inlet conditions	
Air temperature range for ducted process air inlet	Min. -22 °F, max. +122 °F

⁽¹⁾ Sulzer may approve applications outside these criteria.

⁽²⁾ 6560 ft above sea level for 580 V compressors.

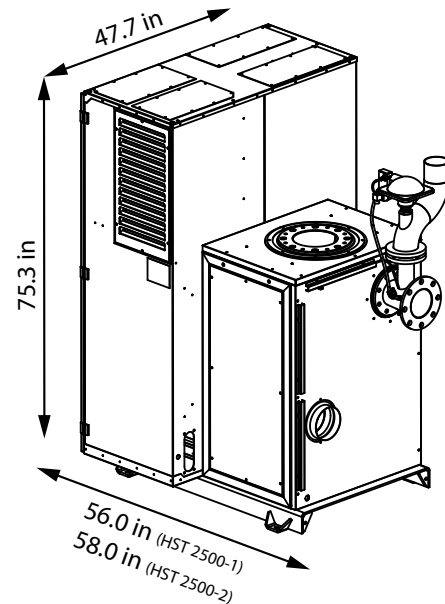

Compressor Data

	HST 2500-	U100-1-L / H	U110-1-L / H	U120-1-L / H	U100-2-L / H	U120-2-L / H	U125-2-L / H
Air flow range [scfm]	L H	550-2400 650-2400	550-2500 650-2500	550-2600 650-2600	400-1400 450-1400	600-1450 750-1400	600-1450 700-1300
Pressure rise [psi]	L H	4.4-9.4 5.8-12.3	4.4-9.4 5.8-12.3	4.4-9.4 5.8-12.3	4.4-9.4 5.8-12.3	11.6-15.2 14.5-18.1	11.6-15.2 14.5-18.1
Noise level [dB]	L H	66 ⁽⁴⁾ 69 ⁽⁴⁾	66 ⁽⁴⁾ 69 ⁽⁴⁾	66 ⁽⁴⁾ 69 ⁽⁴⁾	72 ⁽⁵⁾ 72 ⁽⁵⁾	74 ⁽⁵⁾ 72 ⁽⁵⁾	74 ⁽⁵⁾ 72 ⁽⁵⁾
Input power [hp]		100	110	120	100	120	125
Power supply [V]		460-600	460-500	460-500	460-600	460-500	460-500
Input power frequency [Hz]		50/60	50/60	50/60	50/60	50/60	50/60
480 V	Max. input current [A] ⁽³⁾	97	107	117	97	117	122
	Cable size [AWG or MCM]	3x1/0+3	3x1/0+3	3x1/0+3	3x1/0+3	3x1/0+3	3x1/0+3
	Fuse size [A]	100	125	125	100	125	125
580 V	Max. input current [A] ⁽³⁾	80	not available	not available	80	not available	not available
	Cable size [AWG or MCM]	3x1/0+3	not available	not available	3x1/0+3	not available	not available
	Fuse size [A]	100	not available	not available	100	not available	not available
Auxiliary current [A]		10	10	10	10	10	10
Auxiliary supply [V]		360-550	360-550	360-550	360-550	360-550	360-550
Weight [lb]		1800	1800	1800	1800	1800	1800

⁽³⁾ The maximum input current is calculated using the nominal voltage. The cable and fuse sizes are recommendations and based on the supply current and cables rated to 158 °F.

⁽⁴⁾ The noise values are presented with Outlet Cone Insulation (accessory OCI).

⁽⁵⁾ The noise values are presented without Outlet Cone Insulation (accessory OCI).

www.sulzer.com

SPP id: 17.12.2020 / en / e10435 / 3, Copyright © Sulzer Ltd 2017

This document does not provide a warranty or guarantee of any kind. Please contact us for a description of the warranties and guarantees offered with our products. Directions for use and safety will be given separately. All information herein is subject to change without notice.